

Preliminary



# GW5AT series of FPGA Product Data Sheet

DS981-1.0E, 03/14/2024

# Preliminary

Copyright © 2024 Guangdong Gowin Semiconductor Corporation. All Rights Reserved.

**GOWIN**, **LittleBee**, **Arora**, **Arora-V** are trademarks of Guangdong Gowin Semiconductor Corporation and are registered in China and/or other countries or regions. All other words and logos identified as trademarks or service marks are the property of their respective holders. No part of this document may be reproduced or transmitted in any form or by any means, electronic, mechanical, photocopying, recording or otherwise, without the prior written consent of GOWINSEMI.

## Disclaimer

GOWINSEMI assumes no liability and provides no warranty (either expressed or implied) and is not responsible for any damage incurred to your hardware, software, data, or property resulting from usage of the materials or intellectual property except as outlined in the GOWINSEMI Terms and Conditions of Sale. All information in this document should be treated as preliminary. GOWINSEMI may make changes to this document at any time without prior notice. Anyone relying on this documentation should contact GOWINSEMI for the current documentation and errata.

# Preliminary

## Revision History

Date	Version	Description
03/14/2024	1.0E	Preliminary version published.

# Contents

<b>Contents</b> .....	<b>i</b>
<b>List of Figures</b> .....	<b>iv</b>
<b>List of Tables</b> .....	<b>v</b>
<b>1 General Description</b> .....	<b>1</b>
1.1 Features.....	1
1.2 Product Resources .....	4
<b>2 Architecture</b> .....	<b>7</b>
2.1 Architecture Overview.....	7
2.2 Configurable Function Units .....	9
2.3 Input/Output Blocks .....	10
2.3.1 I/O Buffer .....	11
2.3.2 I/O Logic .....	21
2.3.3 I/O Logic Modes.....	23
2.4 Block SRAM (BSRAM) .....	23
2.4.1 Introduction .....	23
2.4.2 Configuration Mode .....	23
2.4.3 Data Width Configuration .....	25
2.4.4 ECC(GW5AT-75 / GW5AT-138).....	26
2.4.5 Byte-enable.....	26
2.4.6 Synchronous Operation.....	26
2.4.7 BSRAM Operation Modes .....	27
2.4.8 Clock Operations .....	28
2.5 DSP Blocks .....	30
2.5.1 PADD .....	30
2.5.2 MULT .....	31
2.5.3 ALU .....	31
2.5.4 Operating Mode .....	31
2.6 Gigabit Transceivers .....	31
2.7 PCI Express (PCIe) Controller.....	33
2.8 MIPI D-PHY .....	34
2.8.1 MIPI D-PHY RX(GW5AT-138 / GW5AT-75) .....	34

2.8.2 MIPI D-PHY (GW5AT-60) .....	34
2.8.3 GPIOs Support MIPI D-PHY RX/TX (MIPI IO) .....	34
2.9 MIPI C-PHY (GW5AT-60) .....	35
2.10 ADC .....	36
2.10.1 ADC (GW5AT-138 / GW5AT-75).....	36
2.10.2 ADC (GW5AT-60) .....	36
2.11 Clock .....	37
2.11.1 Global Clock.....	38
2.11.2 HCLK.....	38
2.11.3 Phase-locked Loop .....	40
2.11.4 DDR Memory Interface Clock Management DQS .....	40
2.11.5 Long Wire.....	41
2.12 Global Set/Reset (GSR) .....	41
2.13 Programming & Configuration .....	41
2.14 On Chip Oscillator.....	43
<b>3 AC/DC Characteristic.....</b>	<b>44</b>
3.1 Operating Conditions .....	44
3.1.1 Absolute Max. Ratings.....	44
3.1.2 Recommended Operating Conditions .....	45
3.1.3 Power Supply Ramp Rates .....	46
3.1.4 Hot Socket Specifications .....	47
3.1.5 POR Specifications.....	47
3.2 ESD performance .....	47
3.3 DC Characteristics.....	48
3.3.1 DC Electrical Characteristics over Recommended Operating Conditions .....	48
3.3.2 Static Current.....	48
3.3.3 Recommended I/O Operating Conditions .....	49
3.3.4 Single ended I/O DC Characteristic.....	50
3.3.5 Differential I/O DC Characteristic .....	51
3.4 AC Switching Characteristics.....	52
3.4.1 CFU Switching Characteristics .....	52
3.4.2 BSRAM Switching Characteristics.....	52
3.4.3 DSP Switching Characteristics .....	52
3.4.4 Clock and I/O Switching Characteristic .....	53
3.4.5 On chip Oscillator Switching Characteristics .....	54
3.4.6 PLL Switching Characteristics .....	54
3.5 Gigabit Transceiver Performance .....	55
3.5.1 Transceiver Performance .....	55
3.5.2 Transceiver PLL Performance .....	55

---

3.6 Configuration Interface Timing Specification .....	55
<b>4 Ordering Information.....</b>	<b>56</b>
4.1 Part Name.....	56
4.2 Package Mark.....	57
<b>5 About This Guide.....</b>	<b>58</b>
5.1 Purpose .....	58
5.2 Related Documents .....	58
5.3 Terminology and Abbreviations.....	58
5.4 Support and Feedback .....	60

## List of Figures

Figure 2-1 Architecture Diagram (GW5AT-75 / GW5AT-138) .....	7
Figure 2-2 Architecture Diagram (GW5AT-60).....	8
Figure 2-3 CFU Structure View .....	10
Figure 2-4 IOB Structure View .....	11
Figure 2-5 Bank Distribution View of GW5AT-75 / GW5AT-138 .....	12
Figure 2-6 Bank Distribution View of GW5AT-60.....	12
Figure 2-7 I/O Logic Output .....	21
Figure 2-8 I/O Logic Input .....	21
Figure 2-9 IODELAY .....	22
Figure 2-10 Diagram of I/O registers .....	22
Figure 2-11 Pipeline Mode in Single Port, Dual Port, and Semi-Dual Port Mode.....	27
Figure 2-12 Independent Clock Mode .....	29
Figure 2-13 Read/Write Clock Mode.....	29
Figure 2-14 Single Port Clock Mode .....	30
Figure 2-15 Gigabit Transceiver Architecture View.....	32
Figure 2-16 GW5AT-138 / GW5AT-75 Clock Resource.....	37
Figure 2-17 GW5AT-60 Clock Resource.....	38
Figure 2-18 GW5AT-138 / GW5AT-75 HCLK Distribution.....	39
Figure 2-19 GW5AT-60 HCLK Distribution .....	39
Figure 4-1 Part Naming Examples–ES .....	56
Figure 4-2 Part Naming Examples–Production .....	57
Figure 4-3 Package Mark Examples.....	57

## List of Tables

Table 1-1 Product Resources.....	4
Table 1-2 GW5AT-138 Package Information .....	5
Table 1-3 GW5AT-75 Package Information.....	5
Table 1-4 GW5AT-60 Package Information.....	5
Table 2-1 Output I/O Standards and Configuration Options (GW5AT-138 / GW5AT-75) .....	13
Table 2-2 Input I/O Standards and Configuration Options (GW5AT-138 / GW5AT-75).....	15
Table 2-3 Output I/O Standards and Configuration Options (GW5AT-60).....	16
Table 2-4 Input I/O Standards and Configuration Options (GW5AT-60).....	18
Table 2-5 DES /SER Ratios Supported by GW5AT Series of FPGA Products .....	22
Table 2-6 Memory Size Configuration.....	24
Table 2-7 Read/Write Data Width Configuration in Dual Port Mode .....	25
Table 2-8 Read/Write Data Width Configuration in Semi Dual Port Mode.....	26
Table 2-9 Read/Write Data Width Configuration in Semi Dual Port Mode with ECC Function(GW5AT-138) .....	26
Table 2-10 Clock Operations in Different BSRAM Modes .....	28
Table 2-11 List of GW5AT series of FPGA Products that Support MIPI IO Mode.....	35
Table 3-1 Absolute Max. Ratings (GW5AT-138 / GW5AT-75).....	44
Table 3-2 Absolute Max. Ratings (GW5AT-60) .....	45
Table 3-3 Recommended Range(GW5AT-138 / GW5AT-75) .....	45
Table 3-4 Recommended Range(GW5AT-60) .....	46
Table 3-5 Power Supply Ramp Rates .....	46
Table 3-6 Hot Socket Specifications .....	47
Table 3-7 POR Paramrters.....	47
Table 3-8 GW5AT ESD - HBM .....	47
Table 3-9 GW5AT ESD - CDM .....	47
Table 3-10 DC Electrical Characteristics over Recommended Operating Conditions.....	48
Table 3-11 Static Current .....	48
Table 3-12 I/O Operating Conditions Recommended .....	49
Table 3-13 Single-ended DC Characteristic.....	50
Table 3-14 Differential I/O DC Characteristic.....	51
Table 3-15 CFU Timing Parameters.....	52
Table 3-16 BSRAM Timing Parameters .....	52



Table 3-17 DSP Timing Parameters.....	52
Table 3-18 External Switching Characteristics.....	54
Table 3-19 On chip Oscillator Switching Characteristics .....	54
Table 3-20 PLL Switching Characteristic .....	54
Table 3-21 Transmitter and Receiver Data Rate Perfomance.....	55
Table 3-22 Transceiver PLL Performance.....	55
Table 5-1 Terminology and Abbreviations .....	58

# 1 General Description

GOWINSEMI GW5AT series of FPGA products are the 5th-generation of Arora family, with abundant internal resources, a new-architecture and high-performance DSP supporting AI operations, high-speed LVDS interfaces, and abundant BSRAM resources. At the same time, it integrates self-developed DDR3, 12.5Gbps SerDes supporting multiple protocols, and provides a variety of packages. It is suitable for applications such as low power, high performance and compatibility designs.

GOWINSEMI provides a new generation of FPGA hardware development environment that supports FPGA synthesis, placement & routing, bitstream generation and download, etc.

## 1.1 Features

- Lower power consumption
  - 22nm SRAM process
  - Core power (LV version): 0.9V / 1.0V
  - Core voltage (EV <sup>[1]</sup> version): 1.2V
- **Note!**
  - [1] The EV version (supported by GW5AT-60) has a built-in LDO and supports 1.2V V<sub>CC</sub>.
- Supports dynamic on/off of clock
- Abundant basic logic cells
  - GW5AT-138 provides up to 138K LUT4s
  - GW5AT-75 provides up to 86.6K LUT4s
  - GW5AT-60 provides 59.9K LUT4s
  - Supports shadow SRAMs
- Block SRAMs with multiple modes
  - Supports Dual Port, Single Port, Semi Dual Port, and ROM
  - Supports bytes write enable
  - Supports ECC detection and error correction
- Supports multiple transmission protocols such as 270 Mbps to 12.5G bps custom SerDes protocols and 10G Ethernet, etc.
- Supports PCIe 3.0 hard core
  - Supports x1, x2, x4, x8 lanes
  - Supports Root Complex and End Point
- Supports MIPI D-PHY RX hard core
  - Supports MIPI DSI and MIPI CSI-2 RX
  - Up to 2.5 Gbps per MIPI lane
  - Supports up to eight data

- lanes and two clock lanes, with the max. transmission speed up to 20Gbps
  - Supports MIPI D-PHY RX/TX hard core (GW5AT-60)
    - Supports MIPI DSI and MIPI CSI-2 RX/TX
    - Up to 2.5 Gbps per MIPI lane(RX/TX)
    - Supports up to four data lanes and one clock lanes, with the max. transmission bandwidth up to 10Gbps
  - GPIO supports MIPI D-PHY RX (MIPI IO, GW5AT-138 / GW5AT-75)
    - GPIO can be configured as MIPI DSI and MIPI CSI-2 RX interfaces
    - Up to 1.5 Gbps per MIPI lane
  - GPIO supports MIPI C-PHY RX/TX and D-PHY RX/TX (MIPI IO, GW5AT-60)
    - GPIO can be configured as MIPI DSI and MIPI CSI-2 RX/TX interfaces
    - Up to 1.5 Gbps per MIPI lane
  - High performance DSP blocks with a new architecture
    - High performance digital signal processing
    - Supports 27 x 18, 12 x 12, 27 x 36 multiplier and 48-bit accumulator
    - Supports cascading of multipliers
    - Supports Pipeline mode and Bypass mode
    - Pre-addtion operation for filter function
    - Supports barrel shifter
  - A new and flexible X-channel oversampling ADC with high accuracy, no external voltage source required (GW5AT-75 / GW5AT-138)
    - Integrates two kinds of ADC: SARADC and ADC Sensor (GW5AT-60)
    - Supports various SDRAM interfaces, up to DDR3 1333 Mb/s
    - Multiple I/O standards
      - Hysteresis option for input signals
      - Supports drive strengths of 2mA <sup>[1]</sup>, 4mA, 6mA <sup>[1]</sup>, 8mA, 12mA, 16mA, 24mA <sup>[2]</sup>, etc.
- Note!**
- <sup>[1]</sup> GW5AT-60 supports 2mA and 6 mA.
- <sup>[2]</sup> GW5AT-138 / GW5AT-75 supports 24mA.
- Individual Bus Keeper, Pull-up, Pull-down, and Open Drain options
  - Hot Socket
  - 16 global clocks, 8 / 12 high-performance PLLs, 20 / 24 high speed clocks
  - GW5AT-60 MIPI D-PHY, MIPI C-PHY, PLL and ADC modules support Mini Dynamic Re-Program Port (mDRP)
  - Configuration & Programming
    - JTAG configuration
    - Four GowinConfig configuration modes: SSPI, MSPI, Master CPU, Slave CPU, Master SERIAL, Slave SERIAL, and PCIe
    - Supports programming the SPI Flash directly in JTAG and SSPI modes; For other modes, you can program the SPI Flash using the IP
    - Supports background upgrade
    - Supports bitstream file encryption and security bit

settings

- Supports configuration memory soft error recovery (CMSER)
- Supports OTP. Offers a unique 64-bit DNA identifier for each device

## 1.2 Product Resources

Table 1-1 Product Resources

Device	GW5AT-15	GW5AT-60	GW5AT-75	GW5AT-138
LUT4	15120	59904	86688	138240
Flip-Flop (REG)	15120	59904	86688	138240
Distributed Static Random Access Memory SSRAM(Kb)	118.125	468 <sup>[4]</sup>	677	1080
Block Static Random Access Memory BSRAM(Kb)	630	2124 <sup>[4]</sup>	4608	6120
Number of BSRAMs	35	118	256	340
DSP (27-bit x 18-bit)	34	118	213	298
Maximum phase locked loop <sup>[1]</sup> (PLLs)	2	8	12	12
Global Clocks	16	16	16	16
High-speed Clocks	8	20	24	24
Transceivers <sup>[3]</sup>	4	4	8	8
Transceivers Rate	270Mbps-10Gbps	270Mbps - 12.5Gbps	270Mbps-12.5Gbps	270Mbps - 12.5Gbps
PCIe 2.0	1, x1, x2, x4 PCIe 2.0	1, x1, x2, x4 PCIe 2.0	1, x1, x2, x4, x8 PCIe 2.0	1, x1, x2, x4, x8 PCIe 2.0
LVDS Gbps	1.25	1.25	1.25	1.25
DDR3 Mbps	1333	1333	1333	1333
MIPI DPHY hard core	2.5Gbps (RX/TX), 4 data lanes 1 clock lanes	2.5Gbps (RX/TX), 4 data lanes 1 clock lanes	2.5Gbps (RX) 8 data lanes 2 clock lanes	2.5Gbps (RX) 8 data lanes 2 clock lanes
MIPI CPHY hard core	2.5Gsps (=5.75Gbps,RX/TX), 3-trios data lanes	2.5Gsps (=5.75Gbps,RX/TX), 3-trios data lanes	-	-
ADC	1	2	2	2
Number of GPIO banks	4	11	6	6
Maximum number of GPIOs <sup>[5]</sup>	52	320	312	312
Core voltage	0.9V/1.0V	0.9V/1.0V/1.2V <sup>[2]</sup>	0.9V/1.0V	0.9V/1.0V

**Note!**

- <sup>[1]</sup> Different packages support different numbers of PLLs. Here is the max. PLLs supported.
- <sup>[2]</sup> The EV version has a built-in LDO and supports 1.2V V<sub>CC</sub>.
- <sup>[3]</sup> Different packages support different numbers of Transceivers. Here is the max. Transceivers supported.

- <sup>[4]</sup> The GW5AT-60 ES device offers 72 BSRAM and the capacity is 1296Kb.
- <sup>[5]</sup> This is the max. number of GPIOs that the device can provide without package limitation. Please refer to Table 1-2, Table 1-3, and Table 1-4 for the max. number of user I/Os available for the specific packages.

**Table 1-2 GW5AT-138 Package Information**

Package			Pitch (mm)	Size (mm)	GW5AT-138		
Name	Type	Description			I/O (True LVDS Pair)	Transceivers <sup>[1]</sup>	MIPI D-PHY Hardcore
FPG676A	FCPBGA	Flip Chip	1.0	27 x 27	312 (150)	8	RX 8 data lanes 2 clock lanes
PG676A	PBGA	Wire Bond	1.0	27 x 27	312 (150)	8	RX 8 data lanes 2 clock lanes
PG484A	PBGA	Wire Bond	1.0	23 x 23	297 (143)	4	–
PG484	PBGA	Wire Bond	1.0	23 x 23	277 (133)	4	RX 8 data lanes 2 clock lanes
UG324A	UBGA	Wire Bond	0.8	15x15	141 (68)	4	RX 8 data lanes 2 clock lanes

**Note!**

- <sup>[1]</sup> Transceivers in PBGA packages support data rates up to 10.3125 Gbps. When the speed exceeds 8 Gbps, it only supports on-board interconnects, not backplane applications.
- <sup>[1]</sup> Transceivers in FCPBGA packages support data rates up to 12.5 Gbps.

**Table 1-3 GW5AT-75 Package Information**

Package			Pitch (mm)	Size (mm)	GW5AT-75		
Name	Type	Description			I/O (True LVDS Pair)	Transceivers <sup>[1]</sup>	MIPI D-PHY Hardcore
UG484	UBGA	Wire Bond	0.8	19x19	311 (150)	8	RX 8 data lanes 2 clock lanes

**Note!**

<sup>[1]</sup> Transceivers in UBGA packages support data rates up to 10.3125 Gbps. When the speed exceeds 8 Gbps, it only supports on-board interconnects, not backplane applications.

**Table 1-4 GW5AT-60 Package Information**

Package			Pitch (mm)	Size (mm)	GW5AT-60			
Name	Type	Description			I/O (True LVDS Pair)	Transceivers <sup>[1]</sup>	MIPI D-PHY Hardcore	MIPI C-PHY Hardcore
PG484A	PBGA	Wire Bond	1.0	23x23	297(143)	4		
UG225	UBGA	Wire Bond	0.8	13x13	113(53)	4	RX/TX 4 data lanes 1 clock lanes	RX/TX 3-trios data lanes

**Note!**

<sup>[1]</sup> Transceivers in UBGA packages support data rates up to 10.3125 Gbps. When the

speed exceeds 8 Gbps, it only supports on-board interconnects, not backplane applications.

# 2 Architecture

## 2.1 Architecture Overview

Figure 2-1 Architecture Diagram (GW5AT-75 / GW5AT-138)

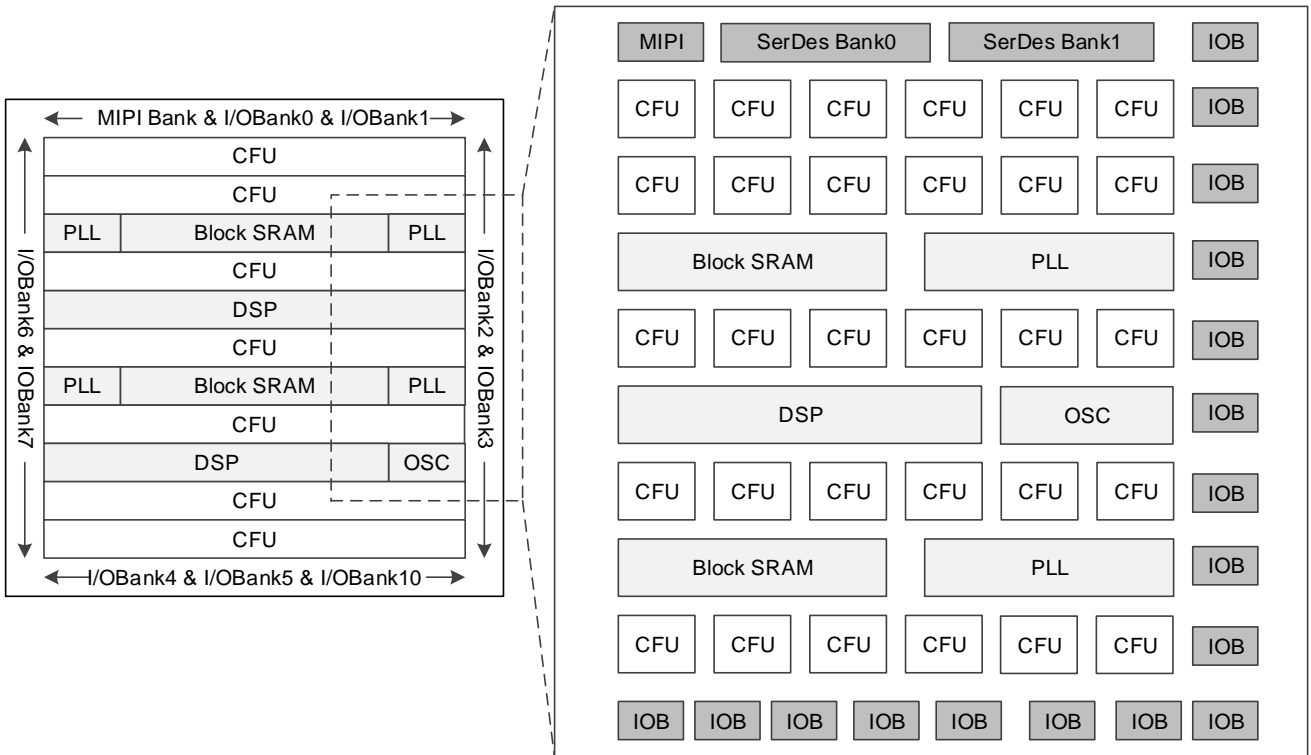



Figure 2-2 Architecture Diagram (GW5AT-60)

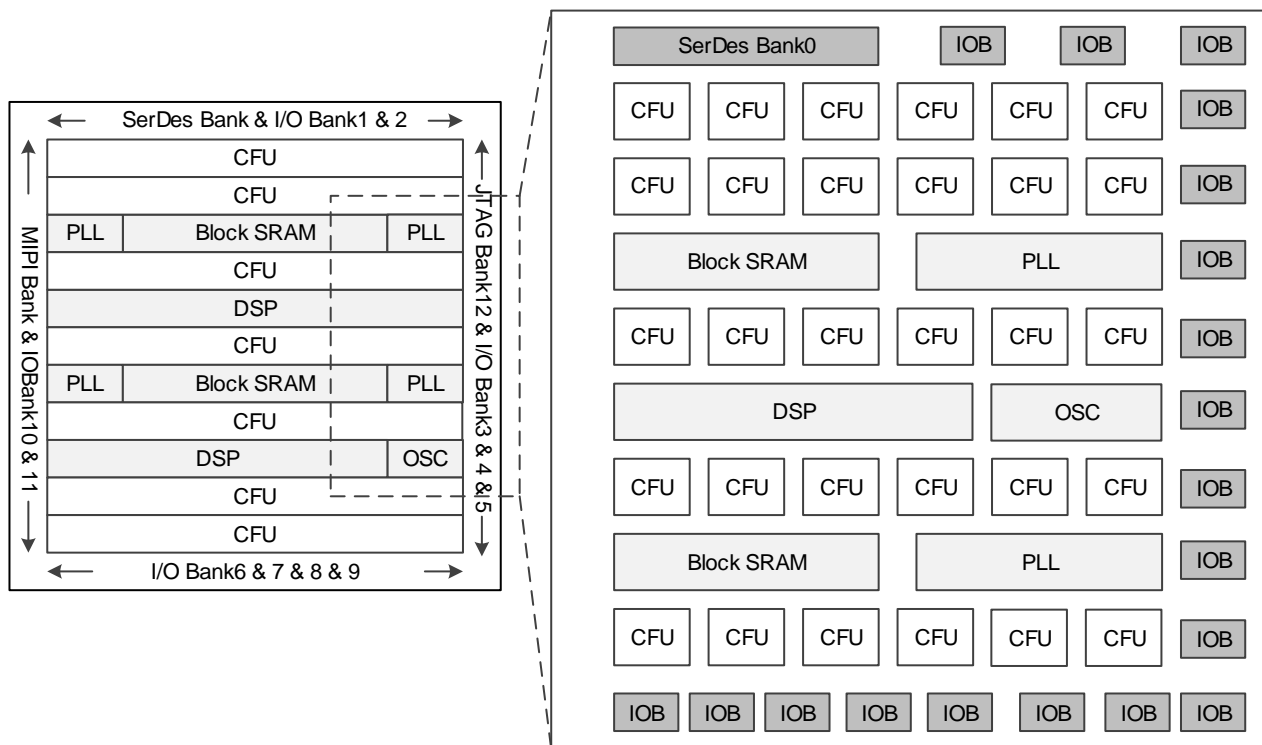

Figure 2-1 is an overview of the architecture of GW5AT-75 / GW5AT-138.

Figure 2-2 is an overview of the architecture of GW5AT-60.

Please refer to Table 1-1 for device internal resources. The core of the device is an array of Configurable Logic Units (CFU) surrounded by IO blocks. Besides, BSRAMs, DSP blocks, Gigabit Transceiver, MIPI D-PHY, ADC, PLLs, and on chip oscillators are provided.

Configurable Function Unit (CFU) is the base cell for the array of the GW5AT series of FPGA Products. Devices with different capacities have different numbers of rows and columns. CFU can be configured as LUT4 mode, ALU mode, and memory mode. For more detailed information, see [2.2 Configurable Function Units](#).

The I/O resources in the GW5AT series of FPGA products are arranged around the periphery of the devices in groups referred to as banks. I/O resources support multiple I/O standards, and support regular mode, SRD mode, generic DDR mode, and DDR\_MEM mode. For more detailed information, see [2.3 Input/Output Blocks](#).

The BSRAM is embedded as a row in GW5AT series of FPGA products. Each BSRAM has a maximum capacity of 36Kbits and consists of two 18Kbits BSRAMs. It supports multiple configuration modes and operation modes. For more detailed information, see [2.4 Block SRAM \(BSRAM\)](#).

GW5AT series of FPGA products are embedded with a brand-new DSP, which can meet the high-performance digital signal processing

requirements. For details, refer to [2.5 DSP Blocks](#).

GW5AT series of FPGA products include Gigabit Transceiver Quads, each of which supports up to 4 transceivers. For details, refer to [2.6 Gigabit Transceiver](#).

GW5AT series of FPGA products provide a MIPI D-PHY hardcore supporting the “MIPI Alliance Standard for D-PHY Specification(V1.2)”. For details, see [2.8 MIPI D-PHY](#).

GW5AT series of FPGA products integrate different ADCs. For details, see [2.10 ADC](#).

GW5AT series of FPGA products have embedded PLL resources. PLL blocks provide the ability to synthesize clock frequencies. Frequency adjustment (multiply and division), phase adjustment, and duty cycle can be adjusted using the configuration of parameters. This series of FPGAs also have an embedded programmable on-chip clock oscillator that supports clock frequencies ranging from 1.67 MHz to 105MHz, providing clocking resources for the MSPI mode. The on-chip clock oscillator also provides programmable user clocks. For more information, see [2.14 On Chip Oscillator](#).

FPGA provides abundant CRUs, connecting all the resources in FPGA. For example, routing resources distributed in CFU and IOB connect resources in CFU and IOB. Routing resources can automatically be generated by Gowin software. In addition, the GW5AT series of FPGA Products also provide abundant GCLKs, long wires (LW), global set/reset (GSR), and programming options, etc. For more details, see [2.12 Global Set/Reset \(GSR\)](#), and [2.13 Programming & Configuration](#).

## 2.2 Configurable Function Units

Configurable Function Units (CFUs) are the basic cells for the array of GOWINSEMI FPGA Products. Each basic cell consists of four Configurable Logic Sections (CLSs) and their routing resource Configurable Routing Units (CRUs). Each CLS includes two 4 input look-up-tables (LUTs) and two registers (REGs), as shown in Figure 2-3 .

CLSs in the CFUs can be configured as basic look-up tables, arithmetic logic units, static random access memories, and read only memories according to application scenarios.

For more details, please see [UG303, Arora V Configurable Function Unit \(CFU\) User Guide](#).

Figure 2-3 CFU Structure View

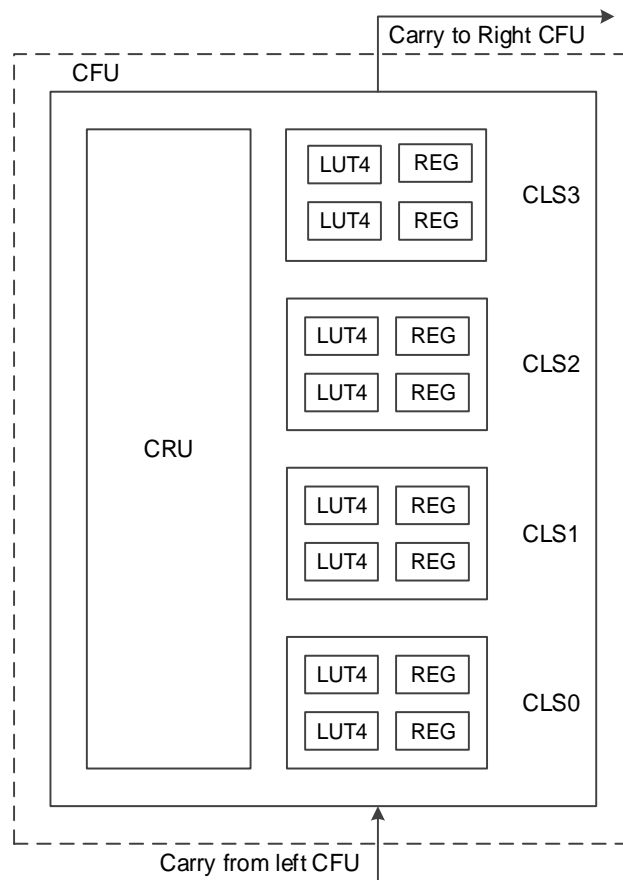

## 2.3 Input/Output Blocks

The IOB in the GW5AT series of FPGA products includes IO buffer, IO logic, and its routing unit. As shown in Figure 2-4, each IOB connects to two Pins (Marked as A and B). They can be used as a differential pair or as a single end input/output.

Figure 2-4 IOB Structure View

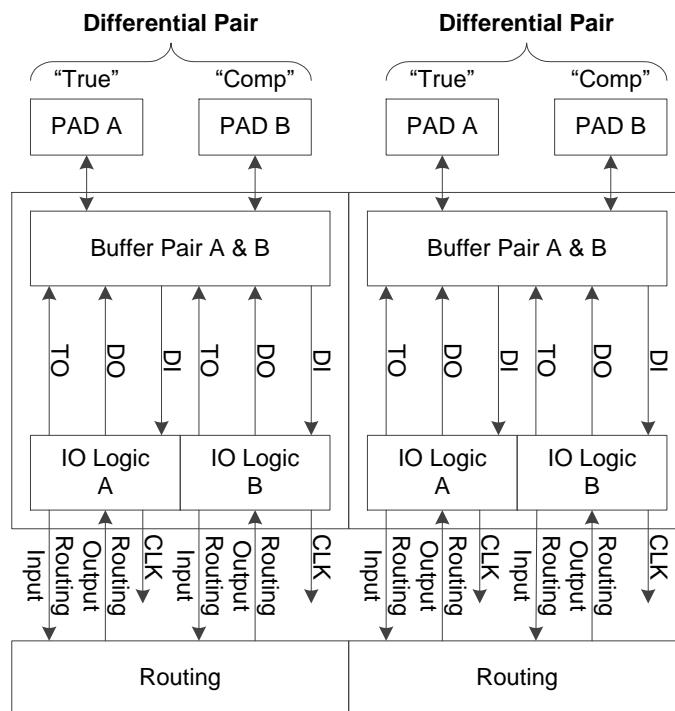

## IOB Features:

- V<sub>CCIO</sub> supplied with each bank
- All banks support True differential input
- Supports multiple levels: LVCMOS, PCI, LVTTTL, SSTL, HSTL, LVDS, Mini\_LVDS, RSDS, PPDS, BLVDS
- Input hysteresis option
- Output drive strength option
- GW5AT-15 / GW5AT-60 supports Slew Rate
- Individual bus keeper, weak pull-up, weak pull-down, and open drain option
- Hot socket
- IO logic supports SDR mode, DDR mode, etc.

### 2.3.1 I/O Buffer

GW5AT-75 / GW5AT-138 has six GPIO Banks (Bank2~ Bank7), two SerDes Banks and a Bank for configuration (Bank 10), as shown in Figure 2-5Figure . Bank 10 can also be used as an I/O Bank.

**Figure 2-5 Bank Distribution View of GW5AT-75 / GW5AT-138**

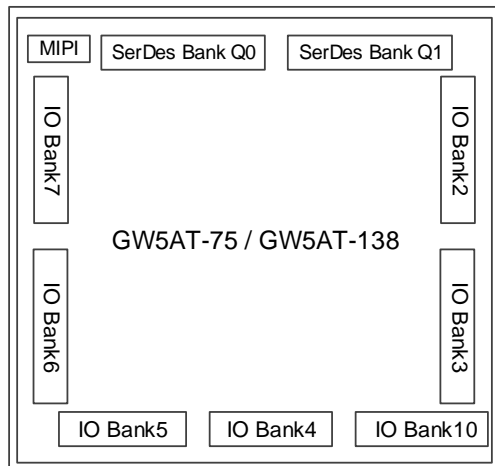

Each Bank has its independent I/O power supply  $V_{CCIO}$ .  $V_{CCIO}$  can be set as 3.3V, 2.5V, 1.8V, 1.5V, 1.35V, 1.2V, or 1V. The auxiliary voltage  $V_{CCX}$  of GW5AT-75 / GW5AT-138 devices support 1.8V.

**Note!**

GW5AT-75 / GW5AT-138: To support SSTL, HSTL, etc., each bank also provides one independent voltage source (VREF) as the reference voltage. You can choose from the internal reference voltage of the bank (0.6V, 0.675V, 0.75V, 0.9V, and (33%,42%,50%,58%) $V_{CCIO}$ ) or the external reference voltage using any IO from the bank.

GW5AT-60 has eleven GPIO Banks (Bank1~ Bank11), one SerDes Bank and two MIPI Banks, as shown in Figure 2-6. Bank 12 is the JTAG bank with four I/Os.

**Figure 2-6 Bank Distribution View of GW5AT-60**

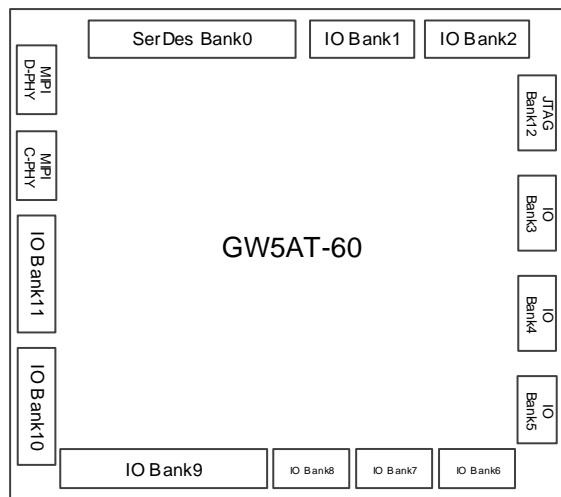

Each Bank has its independent I/O power supply  $V_{CCIO}$ .  $V_{CCIO}$  can be set as 3.3V, 2.5V, 1.8V, 1.5V, 1.35V, or 1.2V. The auxiliary voltage  $V_{CCX}$  of GW5AT-60 devices support 3.3V, 2.5V, or 1.8V.

**Note!**

GW5AT-60: To support SSTL, HSTL, etc., each bank also provides one independent voltage source (VREF) as the reference voltage. You can choose from the internal

reference voltage of the bank (0.6V, 0.75V, 0.9V, 1.25V, 1.5V and (36%,50%,64%) $V_{CCIO}$ ) or the external reference voltage using any IO from the bank.

Different banks in the GW5AT series of FPGA Products support different on-chip resistor settings, including single-ended resistor and differential resistor. Single-ended resistor is set for SSTL/HSTL I/O. Differential resistor is set for LVDS/PPDS/ RSDS input. For more details, refer to [UG304, Arora V Programmable IO \(GPIO\) User Guide](#).

**Note!**

Before and during configuration, all GPIOs of the device have weak pull-up by default. The default I/O state is None after configuration is complete and it can be configured via the Gowin software. The status of configuration-related I/Os differs depending on the configuration mode.

For the different I/O standards and configuration options supported by GW5AT-138/ GW5AT-75, please refer to

Table 2-1 and Table 2-2.

For the different I/O standards and configuration options supported by GW5AT-60, please refer to Table 2-3 and Table 2-4.

**Table 2-1 Output I/O Standards and Configuration Options (GW5AT-138 / GW5AT-75)**

I/O output standard	Single-ended/ Differential	Bank $V_{CCIO}$ (V)	Drive Strength (mA)	Typical Applications
LVDS25	Differential(TLVDS)	2.5/3.3	3.5/2.5/4.5/6	High-speed point-to-point data transmission
BLVDS25		2.5/3.3	3.5/2.5/4.5/6	Multi-point high-speed data transmission
RSDS		2.5/3.3	3.5/2.5/4.5/6	High-speed point-to-point data transmission
MINILVDS		2.5/3.3	3.5/2.5/4.5/6	LCD timing driver interface and column driver interface
PPLVDS		2.5/3.3	3.5/2.5/4.5/6	LCD row/column driver
LVDS25E	Differential	2.5	8/4/12/16/24	High-speed point-to-point data transmission
BLVDS25E		2.5	8/4/12/16/24	Multi-point high-speed data transmission
MLVDS25E		2.5	8/4/12/16/24	LCD timing driver interface and column driver interface
RSDS25E		2.5	8/4/12/16/24	High-speed point-to-point data transmission
LVPECL33E		3.3	8/4/12/16/24	Universal interface

I/O output standard	Single-ended/ Differential	Bank $V_{CCIO}$ (V)	Drive Strength (mA)	Typical Applications
HSUL12D		1.2	8, 4, 12	LPDDR2
HSUL12D_I		1.2	8, 4, 12	LPDDR2
HSTL15D_I		1.5	8/4/12/16	Memory interface
HSTL15D_II <sup>[4]</sup>		1.5	8/4/12/16	Memory interface
HSTL18D_I		1.8	8/4/12/16	Memory interface
HSTL18D_II		1.8	8/4/12/16	Memory interface
SSTL135D		1.35	8/4/12	Memory interface
SSTL15D		1.5	8/4/12/16	Memory interface
SSTL18D_I		1.8	8/4/12/16/24	Memory interface
SSTL18D_II		1.8	8/4/12/16/24	Memory interface
LPDDR		1.8	8/4/12/16/24	LPDDR and Mobile DDR
LVC MOS10D		1.0E	4	Universal interface
LVC MOS12D		1.2	4/8	Universal interface
LVC MOS15D		1.5	4/8/12	Universal interface
LVC MOS18D		1.8	4/8/12/16/24	Universal interface
LVC MOS25D		2.5	4/8/12/16/24	Universal interface
LVC MOS33D		3.3	8/4/12/16/24	Universal interface
HSUL12	Single-ended	1.2	8/4/12	Memory interface
HSTL12_I		1.2	8/4/12	Memory interface
HSTL15_I		1.5	8/4/12/16	Memory interface
HSTL15_II		1.5	8/4/12/16	Memory interface
HSTL18_I		1.8	8/4/12/16/24	Memory interface
HSTL18_II		1.8	8/4/12/16/24	Memory interface
SSTL135		1.35	8/4/12	Memory interface
SSTL15		1.5	8/4/12/16	Memory interface
SSTL18_I		1.8	8/4/12/16/24	Memory interface
SSTL18_II		1.8	8/4/12/16/24	Memory interface
LVC MOS10		1.0E	4	Universal interface
LVC MOS12		1.2	4/8/12	Universal interface
LVC MOS15		1.5	4/8/12/16	Universal interface
LVC MOS18		1.8	4/8/12/16/24	Universal interface
LVC MOS25		2.5	4/8/12/16/24	Universal interface
LVC MOS33/LVTTL33		3.3	8/4/12/16/24	Universal interface
LPDDR		1.8	8/4/12/16/24	LPDDR and Mobile DDR
PCI33		3.3	8/4/12/16/24	PC and embedded system

Table 2-2 Input I/O Standards and Configuration Options (GW5AT-138 / GW5AT-75)

I/O Input Standard	Single-ended/ Differential	Bank $V_{CCIO}$ (V)	Hysteresis	Need $V_{REF}$
MIPI	Differential	1.2	No	No
ADC_in		2.5/1.0/1.2/1.5/1.8/3.3	No	No
LVDS25		2.5/1.0/1.2/1.5/1.8/3.3	No	No
BLVDS25		2.5/1.0/1.2/1.5/1.8/3.3	No	No
RSDS		2.5/1.0/1.2/1.5/1.8/3.3	No	No
MINILVDS		2.5/1.0/1.2/1.5/1.8/3.3	No	No
PPLVDS		2.5/1.0/1.2/1.5/1.8/3.3	No	No
HSUL12D		1.2/1.0/1.5/1.8/2.5/3.3	No	No
HSTL12D_I		1.2/1.0/1.5/1.8/2.5/3.3	No	No
HSTL15D_I		1.5/1.0/1.2/1.8/2.5/3.3	No	No
HSTL15D_II		1.5/1.0/1.2/1.8/2.5/3.3	No	No
HSTL18D_I		1.8/1.0/1.2/1.5/2.5/3.3	No	No
HSTL18D_II		1.8/1.0/1.2/1.5/2.5/3.3	No	No
SSTL135D		1.35/1.0/1.2/1.5/1.8/2.5/3.3	No	No
SSTL15D		1.5/1.0/1.2/1.8/2.5/3.3	No	No
SSTL18D_I		1.8/1.0/1.2/1.5/2.5/3.3	No	No
SSTL18D_II		1.8/1.0/1.2/1.5/2.5/3.3	No	No
LPDDR		1.8/1.0/1.2/1.5/2.5/3.3	No	No
LVC MOS10D		1.0/1.2/1.5/1.8/2.5/3.3	No	No
LVC MOS12D		1.2/1.0/1.5/1.8/2.5/3.3	No	No
LVC MOS15D	1.5/1.0/1.2/1.8/2.5/3.3	No	No	
LVC MOS18D	1.8/1.0/1.2/1.5/2.5/3.3	No	No	
HSUL12	Single-ended	1.2	No	Yes
HSTL12_I		1.2	No	Yes
HSTL15_I		1.5	No	Yes
HSTL15_II		1.5	No	Yes
HSTL18_I		1.8	No	Yes
HSTL18_II		1.8	No	Yes
SSTL135		1.35	No	Yes
SSTL15		1.5	No	Yes
SSTL18_I		1.8	No	Yes
SSTL18_II		1.8	No	Yes
LVC MOS10		1.0E	No	No
LVC MOS10UD12		1.2	No	No
LVC MOS10UD15		1.5	No	No
LVC MOS10UD18		1.8	No	No



I/O Input Standard	Single-ended/ Differential	Bank $V_{CCIO}$ (V)	Hysteresis	Need $V_{REF}$
LVC MOS10UD25		2.5	No	No
LVC MOS10UD33		3.3	No	No
LVC MOS12		1.2	Yes	No
LVC MOS15		1.5	Yes	No
LVC MOS15OD10		1.0E	Yes	No
LVC MOS15OD12		1.2	Yes	No
LVC MOS15UD18		1.8	Yes	No
LVC MOS15UD25		2.5	Yes	No
LVC MOS15UD33		3.3	Yes	No
LVC MOS18		1.8	Yes	No
LVC MOS18OD10		1.0E	Yes	No
LVC MOS18OD12		1.2	Yes	No
LVC MOS18OD15		1.5	Yes	No
LVC MOS18UD25		2.5	Yes	No
LVC MOS18UD33		3.3	Yes	No
LVC MOS25		2.5	Yes	No
LVC MOS25UD33		3.3	Yes	No
LVC MOS33/LVTT L33		3.3	Yes	No
LVC MOS33OD25		2.5	Yes	No
LPDDR		1.8	Yes	No
PCI33		3.3	Yes	No
VREF1_DRIVER	1.8/1.2/1.35/1.5	No	Yes	

Table 2-3 Output I/O Standards and Configuration Options (GW5AT-60)

I/O output standard	Single-ended/ Differential	Bank $V_{CCIO}$ (V)	Drive Strength (mA)	Typical Applications
MIPI	Differential (MIPI)	1.2	-	Mobile Industry Processor Interface
LVDS25	Differential (TLVDS)	2.5/3.3	3.5/2.5/4.5/6	High-speed point-to-point data transmission
BLVDS25		2.5/3.3	3.5/2.5/4.5/6	Multi-point high-speed data transmission
RSDS		2.5/3.3	3.5/2.5/4.5/6	High-speed point-to-point data transmission
MINILVDS		2.5/3.3	3.5/2.5/4.5/6	LCD timing driver interface and column driver interface
PPLVDS		2.5/3.3	3.5/2.5/4.5/6	LCD row/column driver

I/O output standard	Single-ended/ Differential	Bank $V_{CCIO}$ (V)	Drive Strength (mA)	Typical Applications	
LVDS25E	Differential	2.5	8/2/4/6/12/16	High-speed point-to-point data transmission	
BLVDS25E		2.5	8/2/4/6/12/16	Multi-point high-speed data transmission	
MLVDS25E		2.5	8/2/4/6/12/16	LCD timing driver interface and column driver interface	
RSDS25E		2.5	8/2/4/6/12/16	High-speed point-to-point data transmission	
LVPECL33E		3.3	8/2/4/6/12/16	Universal interface	
HSUL12D		1.2	8/2/4/6	LPDDR2	
HSUL12D_I		1.2	8/2/4/6	LPDDR2	
HSTL15D_I		1.5	8/4/12	Memory interface	
HSTL18D_I		1.8	8/2/4/6/12/16	Memory interface	
HSTL18D_II		1.8	8/2/4/6/12/16	Memory interface	
SSTL12D_I		1.2	8/2/4/6	Memory interface	
SSTL135D_I		1.35	8/2/4/6	Memory interface	
SSTL15D_I		1.5	8/2/4/6/12	Memory interface	
SSTL18D_I		1.8	8/2/4/6/12/16	Memory interface	
SSTL18D_II		1.8	8/2/4/6/12/16	Memory interface	
SSTL25D_I		2.5	8/2/4/6/12/16	Memory interface	
SSTL25D_II		2.5	8/2/4/6/12/16	Memory interface	
SSTL33D_I		3.3	8/2/4/6/12/16	Memory interface	
SSTL33D_II		3.3	8/2/4/6/12/16	Memory interface	
LPDDR		1.8	8/2/4/6/12/16	LPDDR and Mobile DDR	
LVC MOS10D		1.0E	2/4	Universal interface	
LVC MOS12D		1.2	8/2/4/6	Universal interface	
LVC MOS15D		1.5	8/2/4/6/12	Universal interface	
LVC MOS18D		1.8	8/2/4/6/12/16	Universal interface	
LVC MOS25D		2.5	8/2/4/6/12/16	Universal interface	
LVC MOS33D		3.3	8/2/4/6/12/16	Universal interface	
HSUL12		Single-ended	1.2	8/2/4/6	Memory interface
HSTL12_I			1.2	8/2/4/6	Memory interface
HSTL15_I			1.5	8/2/4/6/12	Memory interface
HSTL18_I			1.8	8/2/4/6/12/16	Memory interface
HSTL18_II			1.8	8/2/4/6/12/16	Memory interface
SSTL12_I			1.2	8/2/4/6	Memory interface
SSTL135_I	1.35		8/2/4/6	Memory interface	

I/O output standard	Single-ended/ Differential	Bank $V_{CCIO}$ (V)	Drive Strength (mA)	Typical Applications
SSTL15_I		1.5	8/2/4/6/12	Memory interface
SSTL18_I		1.8	8/2/4/6/12/16	Memory interface
SSTL18_II		1.8	8/2/4/6/12/16	Memory interface
SSTL25_I		2.5	8/2/4/6/12/16	Memory interface
SSTL25_II		2.5	8/2/4/6/12/16	Memory interface
SSTL33_I		3.3	8/2/4/6/12/16	Memory interface
SSTL33_II		3.3	8/2/4/6/12/16	Memory interface
LVC MOS10		1.0E	2/4	Universal interface
LVC MOS12		1.2	8/2/4/6	Universal interface
LVC MOS15		1.5	8/2/4/6/12	Universal interface
LVC MOS18		1.8	8/2/4/6/12/16	Universal interface
LVC MOS25		2.5	8/2/4/6/12/16	Universal interface
LVC MOS33/L VTTL33		3.3	8/2/4/6/12/16	Universal interface
LPDDR		1.8	8/2/4/6/12/16	LPDDR and Mobile DDR
PCI33		3.3	8/2/4/6/12/16	PC and embedded system

Table 2-4 Input I/O Standards and Configuration Options (GW5AT-60)

I/O Input Standard	Single-ended/ Differential	Bank $V_{CCIO}$ (V)	Hysteresis	Need $V_{REF}$
MIPI	Differential	1.2	No	No
ADC_IN		2.5/1.0/1.2/1.5/1.8/3.3	No	No
LVDS25		2.5/1.0/1.2/1.5/1.8/3.3	No	No
BLVDS25		2.5/1.0/1.2/1.5/1.8/3.3	No	No
RSDS		2.5/1.0/1.2/1.5/1.8/3.3	No	No
MINILVDS		2.5/1.0/1.2/1.5/1.8/3.3	No	No
PPLVDS		2.5/1.0/1.2/1.5/1.8/3.3	No	No
HSUL12D		1.2/1.0/1.5/1.8/2.5/3.3	No	No
HSTL12D_I		1.2/1.0/1.5/1.8/2.5/3.3	No	No
HSTL15D_I		1.5/1.0/1.2/1.8/2.5/3.3	No	No
HSTL18D_I		1.8/1.0/1.2/1.5/2.5/3.3	No	No
HSTL18D_II		1.8/1.0/1.2/1.5/2.5/3.3	No	No
SSTL135D_I		1.35/1.0/1.2/1.5/1.8/2.5/3.3	No	No
SSTL15D_I		1.5/1.0/1.2/1.8/2.5/3.3	No	No
SSTL18D_I		1.8/1.0/1.2/1.5/2.5/3.3	No	No
SSTL18D_II		1.8/1.0/1.2/1.5/2.5/3.3	No	No
SSTL2D_I		2.5/1.0/1.2/1.5/1.8/3.3	No	No
SSTL2D_II		2.5/1.0/1.2/1.5/1.8/3.3	No	No

I/O Input Standard	Single-ended/ Differential	Bank $V_{CCIO}$ (V)	Hysteresis	Need $V_{REF}$
SSTL3D_I		3.3/1.0/1.2/1.5/1.8/2.5	No	No
SSTL3D_II		3.3/1.0/1.2/1.5/1.8/2.5	No	No
LPDDR		1.8/1.0/1.2/1.5/2.5/3.3	No	No
LVC MOS10D		1.0/1.2/1.5/1.8/2.5/3.3	No	No
LVC MOS12D		1.2/1.0/1.5/1.8/2.5/3.3	No	No
LVC MOS15D		1.5/1.0/1.2/1.8/2.5/3.3	No	No
LVC MOS18D		1.8/1.0/1.2/1.5/2.5/3.3	No	No
LVC MOS25D		2.5/1.0/1.2/1.5/1.8/3.3	No	No
LVC MOS33D		3.3/1.0/1.2/1.5/2.5/1.8	No	No
HSUL12	Single-ended	1.2	Yes	No
HSTL12_I		1.2	Yes	No
HSTL15_I		1.5	Yes	No
HSTL15_II		1.5	Yes	No
HSTL18_I		1.8	Yes	No
HSTL18_II		1.8	Yes	No
SSTL135_I		1.35	Yes	No
SSTL15_I		1.5	Yes	No
SSTL18_I		1.8	Yes	No
SSTL18_II		1.8	Yes	No
SSTL2_I		2.5	Yes	No
SSTL2_II		2.5	Yes	No
SSTL3_I		3.3	Yes	No
SSTL3_II		3.3	Yes	No
LVC MOS10		1.0E	Yes	No
LVC MOS12		1.2	Yes	No
LVC MOS15		1.5	Yes	No
LVC MOS18		1.8	Yes	No
LVC MOS25		2.5	Yes	No
LVC MOS33/LVTT L33		3.3	Yes	No
LPDDR		1.8	Yes	No
PCI33		3.3	Yes	No
LVC MOS10UD12		1.2	Yes	No
LVC MOS10UD15		1.5	Yes	No
LVC MOS10UD18		1.8	Yes	No
LVC MOS10UD25		2.5	Yes	No
LVC MOS10UD33		3.3	Yes	No
LVC MOS12OD10		1.0E	Yes	No
LVC MOS12UD15		1.5	Yes	No

I/O Input Standard	Single-ended/ Differential	Bank $V_{CCIO}$ (V)	Hysteresis	Need $V_{REF}$
LVC MOS12UD18		1.8	Yes	No
LVC MOS12UD25		2.5	Yes	No
LVC MOS12UD33		3.3	Yes	No
LVC MOS15OD10		1.0E	Yes	No
LVC MOS15OD12		1.2	Yes	No
LVC MOS15UD18		1.8	Yes	No
LVC MOS15UD25		2.5	Yes	No
LVC MOS15UD33		3.3	Yes	No
LVC MOS18OD10		1.0E	Yes	No
LVC MOS18OD12		1.2	Yes	No
LVC MOS18OD15		1.5	Yes	No
LVC MOS18UD25		2.5	Yes	No
LVC MOS18UD33		3.3	Yes	No
LVC MOS25OD10		2.5	Yes	No
LVC MOS25OD12		3.3	Yes	No
LVC MOS25OD15		1.5	Yes	No
LVC MOS25OD18		1.8	Yes	No
LVC MOS25UD33		3.3	Yes	No
LVC MOS33OD10		1.0E	Yes	No
LVC MOS33OD12		1.2	Yes	No
LVC MOS33OD15		3.3	Yes	No
LVC MOS33OD18		1.8	Yes	No
LVC MOS33OD25		2.5	Yes	No
VREF1_DRIVER		1.8/1.2/1.35/1.5	No	Yes

### 2.3.2 I/O Logic

Figure 2-7 shows the I/O logic output of GW5AT series of FPGA products.

Figure 2-7 I/O Logic Output

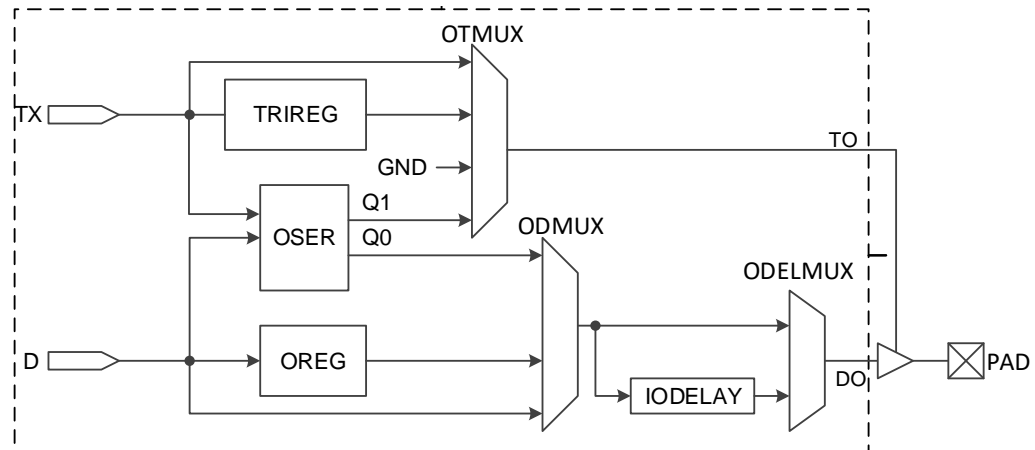
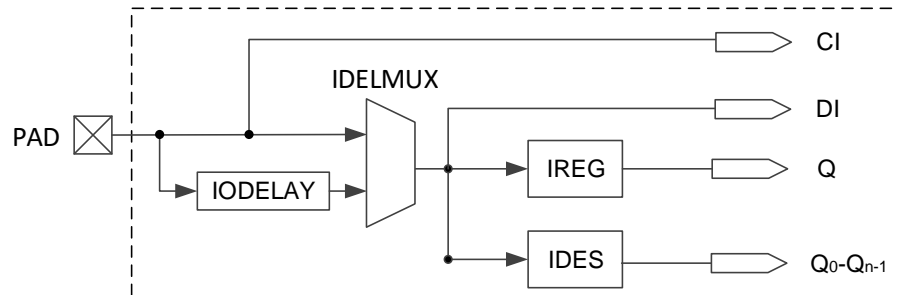

Figure 2-8 shows the I/O logic input of the GW5AT series of FPGA products.

Figure 2-8 I/O Logic Input



Descriptions of the I/O logic modules of GW5AT series of FPGA products are presented below.

#### I/O Delay

See Figure 2-9 for an overview of the IODELAY. Each I/O of GW5AT series FPGA products contains IODELAY module, through which users can add extra delay on IOs to adjust the delay time of output signals.

The delay time for each step is  $T_{dlyunit}$ , and the maximum number of steps is DLYSTEP. The total delay time of IODELAY is:  $T_{maxdly} = T_{dlyoffset} + T_{dlyunit} * DLYSTEP$ . Please refer to Table 2-5 for total delay reference time.

Table 2-5 Total Delay Reference

	Min. (ps)	Typ. (ps)	Max. (ps)
$T_{dlyoffset}$	200	250	300
$T_{dlyunit}$	10	12.5	15
DLYSTEP	0	-	256

**Figure 2-9 IODELAY**

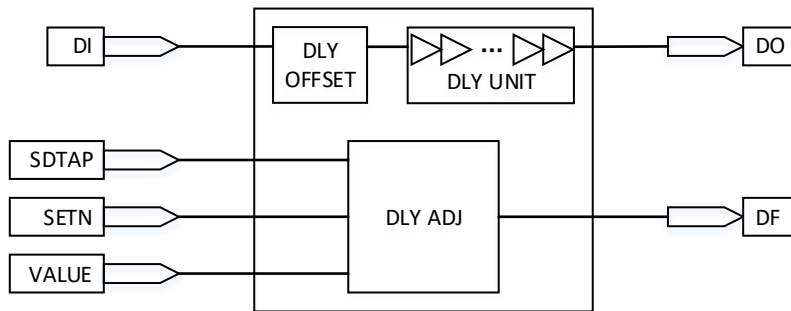

There are three ways to control the delay:

- Static control.
- Dynamic control, which can be combined with logic function circuits to achieve dynamic delay adjustment.
- Adaptive control.

**I/O Register**

See Figure Figure 2-10 for the I/O register in GW5AT series of FPGA products. Each I/O of the GW5AT series of FPGA products provides one input register (IREG), one output register (OREG), and one tristate Register (TRIREG).

**Figure 2-10 Diagram of I/O registers**

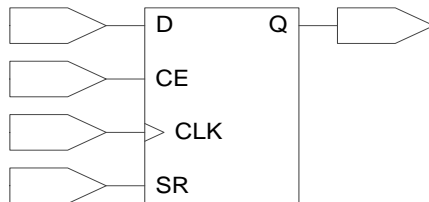

**Note!**

- CE can be either active low (0: enable) or active high (1: enable).
- CLK can be either rising edge trigger or falling edge trigger.
- SR can be either synchronous/asynchronous SET or RESET or disable.
- The registers can be programmed as registers(DFFs) or latches.

**De-serializer DES and Serializer SER**

The GW5AT series of FPGA Products support serialization and deserialization of various ratios, as shown in the following table:

**Table 2-6 DES /SER Ratios Supported by GW5AT Series of FPGA Products**

	Ratios Supported
Input logic	1:2 / 1:4 / 1:7 / 1:8 / 1:10 / 1:14 / 1:16 / 1:32
Output logic	2:1 / 4:1 / 7:1 / 8:1 / 10:1 / 16:1 / 14:1 <sup>[1]</sup>

**Note!**

Only GW5AT-60 supports 14:1 OSER.

### 2.3.3 I/O Logic Modes

The I/O Logic in GW5AT series of FPGA products supports several modes. In each operation, the I/O (or I/O differential pair) can be configured as output, input, and INOUT or tristate output (output signal with tristate control).

For further details about the I/O logic modes, refer to [UG304, Arora V Programmable IO \(GPIO\) User Guide](#).

## 2.4 Block SRAM (BSRAM)

### 2.4.1 Introduction

GW5AT series of FPGA products provide abundant block SRAM resources. These memory resources are distributed throughout the FPGA array in the form of rows. Therefore, they are called block static random access memories (BSRAMs). Up to 36Kbits can be configured for each BSRAM. There are five operation modes: Single Port mode, Dual Port mode, Semi Dual Port mode, Semi Dual Port mode with ECC function, and ROM mode.

An abundance of BSRAM resources provide a guarantee for the user's high-performance design. BSRAM's features:

- Up to 36Kbits per BSRAM
- Clock frequency up to 380MHz
- Supports Single Port mode
- Supports Dual Port mode
- Supports Semi Dual Port Mode
- Supports ECC detection and error correction Function
- Supports ROM Mode
- Data width up to 72bits
- Dual Port and Semi-Dual Port support independent clocks and independent data width
- Read mode supports Register Output and Bypass Output
- Write mode supports Normal and Write-Through

### 2.4.2 Configuration Mode

BSRAMs in the GW5AT series of FPGA products support various data widths. See Table 2-7.



Table 2-7 Memory Size Configuration

Capacity	Single Port Mode	Dual Port Mode	Semi Dual Port Mode	Semi Dual Port Mode with ECC Function	Read Only Mode
16Kbits	16K x 1	16K x 1	16K x 1	–	16K x 1
	8K x 2	8K x 2	8K x 2	–	8K x 2
	4K x 4	4K x 4	4K x 4	–	4K x 4
	2K x 8	2K x 8	2K x 8	–	2K x 8
	1K x 16	1K x 16	1K x 16	–	1K x 16
	512 x 32	–	512 x 32	–	512 x 32
18Kbits	2K x 9	2K x 9	2K x 9	–	2K x 9
	1K x 18	1K x 18	1K x 18	–	1K x 18
	512 x 36	–	512 x 36	–	512 x 36
36Kbits	–	–	–	512 x 72	–

### Single Port Mode

In the single port mode, BSRAM can write to or read from one port at one clock edge. It supports 2 read modes (Bypass and Pipeline) and 2 write modes (Normal mode and Write-Through mode). In Normal-Write Mode, the written data will be stored in the internal memory array. In Write-through Mode, the written data will not only be stored in the internal memory array, but also be written to the output of BSRAM. When the output register is bypassed, the new data will show at the same write clock rising edge.

For more information on single port mode, please refer to [UG300, Arora V BSRAM & SSRAM User Guide](#).

### Dual Port Mode

BSRAM supports Dual Port mode. It supports 2 read modes (Bypass and Pipeline) and 2 write modes (Normal and Write-Through). The applicable operations are as follows:

- Two independent read, reading data from any given address.
- Two independent write, writing data to any address that is different.
- An independent read and an independent write at different clock frequencies.

#### Note!

- In Dual-port mode, Port A and Port B can read from or write to the same address. Null or repeated reads do not damage the storage module.
- In Dual-port mode, when Port A and Port B write to the same address at the same time, the dual ports writing fail at the same time.
- When Port A reads, Port B writes, and they access the same address, the write port succeeds, but the read port fails, and the output data is unknown. BSRAM contents are the values from the write port.

Dual Port supports independent read/write clocks and independent read/write data width. For more information on dual port mode, please refer to [UG300, Arora V BSRAM & SSRAM User Guide](#).

### Semi Dual Port Mode

Semi-dual ports support independent read/write operations in the form of A port write-only ("Normal mode") and B port read-only. When Port A reads, Port B writes, and they access the same address, the write port succeeds, but the read port fails, and the output data is unknown. BSRAM contents are the values from the write port.

Semi-dual Port supports independent read/write clocks and independent read/write data width. For more information on semi dual port mode, please refer to [UG300, Arora V BSRAM & SSRAM User Guide](#).

### Semi Dual Port Mode with ECC Function

Semi-dual ports with ECC Function support independent read/write operations in the form of A port write-only and B port read-only. Independent read/write data width is also supported. This mode provides ECC function. For more information on this mode, please refer to [UG300, Arora V BSRAM & SSRAM User Guide](#).

### Read Only Mode

BSRAM can be configured as ROM. The ROM can be initialized during the device configuration stage, and the ROM data needs to be provided in the initialization file. Initialization completes during the device power-on process.

Each BSRAM can be configured as one 16 Kbits ROM. For more information on read only mode, please refer to [UG300, Arora V BSRAM & SSRAM User Guide](#).

## 2.4.3 Data Width Configuration

BSRAMs in the GW5AT series of FPGA products support independent data width for read/write operations. In Dual Port mode, Semi Dual Port mode, and Semi Dual Port mode with ECC function, the data width for Port A and Port B can be different. For the data width supported by Port A and Port B, see Table 2-8, Table 2-9, and Table 2-10.

Table 2-8 Read/Write Data Width Configuration in Dual Port Mode

Capacity	Port B	Port A						
		16K x 1	8K x 2	4K x 4	2K x 8	1K x 16	2K x 9	1K x 18
16Kbits	16K x 1	Yes	Yes	Yes	Yes	Yes	N/A	N/A
	8K x 2	Yes	Yes	Yes	Yes	Yes	N/A	N/A
	4K x 4	Yes	Yes	Yes	Yes	Yes	N/A	N/A
	2K x 8	Yes	Yes	Yes	Yes	Yes	N/A	N/A
	1K x 16	Yes	Yes	Yes	Yes	Yes	N/A	N/A
18Kbits	2K x 9	N/A	N/A	N/A	N/A	N/A	Yes	Yes
	1K x 18	N/A	N/A	N/A	N/A	N/A	Yes	Yes

Table 2-9 Read/Write Data Width Configuration in Semi Dual Port Mode

Capacity	Port B	Port A										
		16K x 1	8K x 2	4K x 4	2K x 8	1K x 16	512x 32	2K x 9	1K x 18	512 x 36	1K x 36	512 x 72
16Kbits	16K x 1	Yes	Yes	Yes	Yes	Yes	Yes	N/A	N/A	N/A	N/A	N/A
	8K x 2	Yes	Yes	Yes	Yes	Yes	Yes	N/A	N/A	N/A	N/A	N/A
	4K x 4	Yes	Yes	Yes	Yes	Yes	Yes	N/A	N/A	N/A	N/A	N/A
	2K x 8	Yes	Yes	Yes	Yes	Yes	Yes	N/A	N/A	N/A	N/A	N/A
	1K x 16	Yes	Yes	Yes	Yes	Yes	Yes	N/A	N/A	N/A	N/A	N/A
	512 x 32	Yes	Yes	Yes	Yes	Yes	Yes	N/A	N/A	N/A	N/A	N/A
18Kbits	2K x 9	N/A	N/A	N/A	N/A	N/A	N/A	Yes	Yes	Yes	N/A	N/A
	1K x 18	N/A	N/A	N/A	N/A	N/A	N/A	Yes	Yes	Yes	N/A	N/A

Table 2-10 Read/Write Data Width Configuration in Semi Dual Port Mode with ECC Function(GW5AT-138)

Capacity	Port B	Port A	
			512 x 72
36Kbits	512 x 72	N/A	Yes

## 2.4.4 ECC(GW5AT-75 / GW5AT-138)

The BSRAM of GW5AT-138 has a built-in ECC hardcore module, which is mainly used for data detection and correction during data transfer and storage. ECC features are as follows:

- ECC error detection and correction only supported in SDP 512 x 64 mode
- Supports 1-bit error correction and 2-bit error alarm in 64-bit SRAM data
- 72-bit ECC module contains 64-bit data bits and 8-bit parity bits;
- Bit 31 and bit 63 support 1-bit and 2-bit error injection

## 2.4.5 Byte-enable

BSRAM supports the byte\_enable function- only the selected byte can be written. The byte\_enable function is used for writing only and is available when the bit width is 16/18, 32/36. Read/write enable ports (WREA, WREB), and byte parameter options can be used to control the BSRAM write operation.

## 2.4.6 Synchronous Operation

- All the input registers of BSRAM support synchronous write.

- The output register can be used as a Pipeline register to improve design performance.
- The output registers can be bypassed.

### 2.4.7 BSRAM Operation Modes

BSRAM supports four different operations, including two read operations (Bypass and Pipeline) and two write operations (Normal and Write-Through).

#### Read Mode

Read data from the BSRAM via output registers or without using the registers.

##### PIPELINE

When reading data, the data is synchronously read out via the output register according to the clock beat. This mode supports up to 72-bit data width.

##### BYPASS

In this mode, the output register is not used. When reading data, the data is directly sent to the output port.

Figure 2-11 Pipeline Mode in Single Port, Dual Port, and Semi-Dual Port Mode

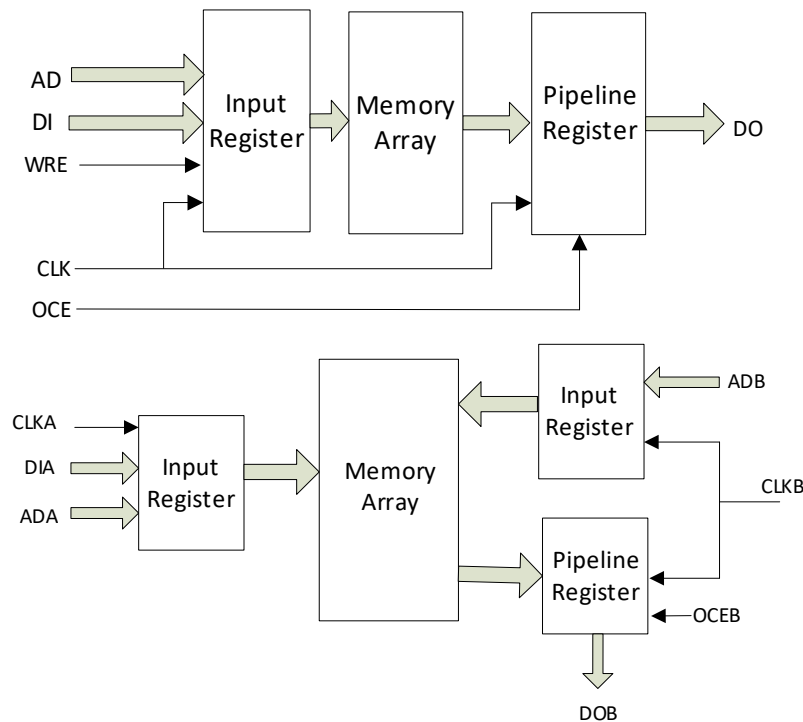

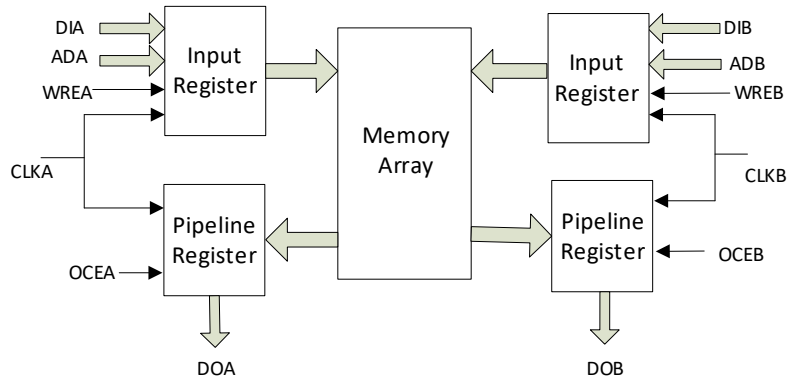

**Write Mode**

**NORMAL MODE**

In this mode, when the user writes data to one port, and the output data of this port does not change. The data written in will not appear at the read port.

**WRITE-THROUGH MODE**

In this mode, when the user writes data to one port, and the data written in will also appear at the output of this port.

**2.4.8 Clock Operations**

Table 2-11 lists the clock operations in different BSRAM modes:

**Table 2-11 Clock Operations in Different BSRAM Modes**

Clock Operations	BSRAM Mode		
	Dual Port Mode	Semi Dual Port Mode	Single Port Mode
Independent Clock Mode	Yes	No	No
Read/Write Clock Mode	Yes	Yes	No
Single Port Clock Mode	No	No	Yes

**Independent Clock Mode**

Figure 2-12 shows the independent clocks in dual port mode with each port with one clock. CLKA controls all the registers at Port A; CLKB controls all the registers at Port B.

**Figure 2-12 Independent Clock Mode**

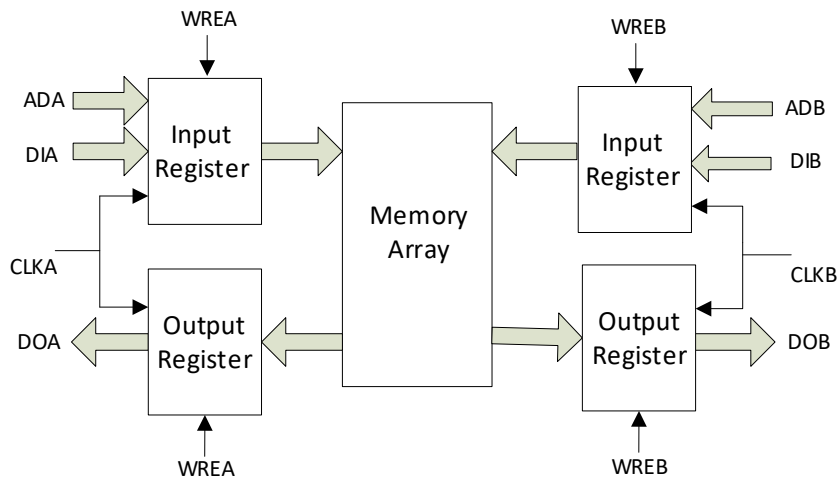

**Read/Write Clock Operation**

Figure 2-13 shows the read/write clock operations in the semi-dual port mode with one clock at each port. The write clock (CLKA) controls Port A data inputs, write address and read/write enable signals. The read clock (CLKB) controls Port B data output, read address, and read enable signals.

**Figure 2-13 Read/Write Clock Mode**

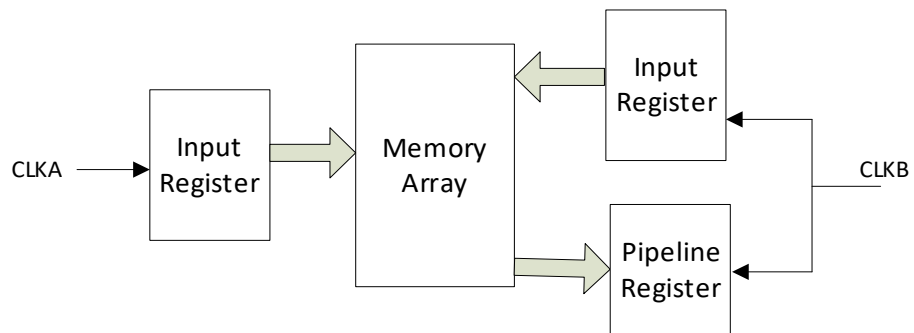

### Single Port Clock Mode

Figure 2-14 shows the clock operation in single port mode.

Figure 2-14 Single Port Clock Mode

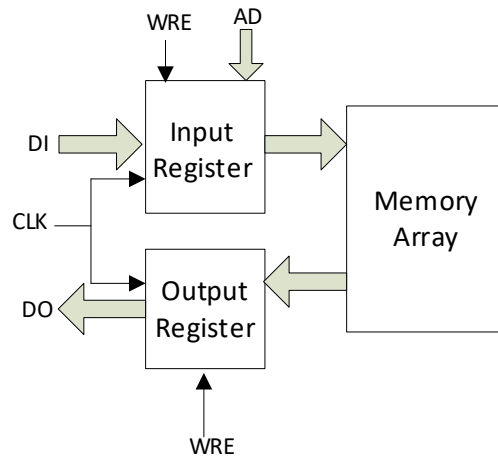

## 2.5 DSP Blocks

GW5AT series of FPGA Products provide brand new DSP resources. This DSP solution can meet user demands for high performance digital signal processing design, such as FIR, FFT, etc. DSP blocks have the advantages of stable timing performance, high resource utilization, and low power consumption.

The features of DSP are as follows.

- Can be configured as 12 x 12, 27 x 28, and 27 x 36 signed multipliers
- 48-bit arithmetic logic unit(ALU)
- Multipliers cascading to support wider data
- Barrel Shifter
- Adaptive filtering through signal feedback
- Supports Pipeline mode and Bypass mode.
- All operands for arithmetic operation are signed numbers

Each DSP consists of three main parts:

- PADD
- MULT
- ALU

### 2.5.1 PADD

Each DSP features one PADD(pre-adder) for implementing pre-addition, pre-subtraction, and shifting.

PADD locates at the first stage with two inputs:

- 26-bit input C;

- Parallel 26-bit input A or SIA.  
Each input end supports Pipeline mode and Bypass mode.

## 2.5.2 MULT

Each DSP block has one 27 x 18 multiplier M0 and one 12 x 12 multiplier M1. The multipliers are located after the pre-adders to implement multiplication operations, and both the inputs and outputs support register mode and Bypass mode.

Multiplier M0 can be configured as:

- One 27 x 18 multiplier
- One 12 x 12 multiplier
- Two DSPs can form a 27 x 36 multiplier

Multiplier M1 can only be configured as one 12 x 12 multiplier.

When multiplier M0 and multiplier M1 are both configured as a 12 x 12 multiplier and the ALU is enabled, 12 x 12 SUM mode can be achieved.

## 2.5.3 ALU

Each DSP has one four-input 48-bit ALU, which can further enhance MULT's functions. Register mode and bypass mode are supported both in the inputs and outputs. The ALU supports the addition/subtraction operations of multiplier M0 output, multiplier M1 output (48bit operand D), ALU cascade input CASI and ALU output feedback, or static PRE\_LOAD value.

## 2.5.4 Operating Mode

Based on control signals, DSP can be configured as different operation modes. Operation Modes:

- Multiplier
- Accumulator
- MULTADDALU

For more information on DSP Blocks, see [UG305, Arora V Digital Signal Processing \(DSP\) User Guide](#).

## 2.6 Gigabit Transceivers

GW5AT-138 / GW5AT-75 supports two Transceiver Quads. GW5AT-60 supports one Transceiver Quad. Each Quad supports up to four transceivers, and each transceiver is comprised of one TX and one RX, with the data rate ranging from 270Mbps to 12.5Gbps, and supports flexible PMA and PCS.

Figure 2-15 shows the structure view of Transceiver Quad. The protocols supported are as follows:

- PCI Express, V2.0 (2.5 Gbps /5.0 Gbps)
- 10 Gigabit Attachment Unit Interface (XAUI) (3.125Gbps)



- RXAUI (Reduced XAUI) (6.25Gbps)
- CEI-6G-SR (6.375Gbps)
- SATA Rev3.2 (6Gbps/3Gbps/1.5Gbps) (need soft IP support)
- Serial GMII(SGMII) (1.25Gbps)
- CPR1 (need soft IP support; soft IP available)
- JESD204B (need soft IP support; soft IP available)
- Rapid-IO (need soft IP support; soft IP available)
- 1000Base-X (need soft IP support; soft IP available)
- 10G-Base-R (need soft IP support; soft IP available)
- SDI-TX/RX(need soft IP support; soft IP available)
- SLVS-EC(RX) (need soft IP support; soft IP available)
- Interlaken (GW5AT-60)

**Figure 2-15 Gigabit Transceiver Architecture View**

Bank 0					Bank 1				
CH0 PMA TX + RX	CH1 PMA TX + RX	Quad 0 Common Logic	CH2 PMA TX + RX	CH3 PMA TX + RX	CH0 PMA TX + RX	CH1 PMA TX + RX	Quad 1 Common Logic	CH2 PMA TX + RX	CH3 PMA TX + RX
CH0 PCS PCIe PCS + Flexible PCS	CH1 PCS PCIe PCS + Flexible PCS		CH2 PCS PCIe PCS + Flexible PCS	CH3 PCS PCIe PCS + Flexible PCS	CH0 PCS PCIe PCS + Flexible PCS	CH1 PCS PCIe PCS + Flexible PCS		CH2 PCS PCIe PCS + Flexible PCS	CH3 PCS PCIe PCS + Flexible PCS
FPGA Fabric									

**PMA**

- Each PMA contains four lanes, each of which supports simultaneous sending and receiving of data, including independent TX and RX, and supports different rates of sending and receiving.
- Each Quad shares two PLLS (one is LC PLL, the other is ring oscillator PLL)
- Transmitter through tracking of spread reference clock.
- Lane driver with programmable transmitter equalization with 1 tap pre-cursor and 1 tap post-cursor to improve signal integrity.
- Voltage mode/current mode lane driver with board AC coupling.
- Programmable continuous time linear equalizer (CTLE) with auto-adaption.
- Receiver CDR track SSC data and tolerance +/- 5000ppm variation.
- Beacon signaling generation and detection for PCI Express.

## PCS

- Dedicated hard PCIe PCS
- Flexible PCS to support PCS customization
- GW5AT-138: 8b/10b encoder/decoder
- GW5AT-60: 8b/10b/64b/66b encoder/decoder
- Supports TX channel bonding
- Supports RX channel bonding and CTC
- Utilize IF FIFO to simplify user system design
- Supports flexible parallel data widths of 8/10/16/20/32/40/64/80 bits

## 2.7 PCI Express (PCIe) Controller

GW5AT include one integrated block for PCI Express technology. It allows custom FPGA-to-FPGA communication via the PCI Express protocol, and to attach ASSP Endpoint devices, such as Ethernet Controllers or Fiber Channel HBAs (Host Bus Adapter), to the FPGA.

Features of the PCIe integrated block are as follows:

- Dedicated hard core IP, Compliant to the PCI Express Base Specification 3.0
- Supports x1, x2, x4, x8 lanes
- Supports Root Complex and End Point
- Supports Gen1 (2.5Gb/s), Gen2 (5Gb/s)
- Up to six BARs, resizable
- Lane reversal
- Lane reversal
- Supports CrossLink connection mode
- Supports Multicast
- Supports ARI (Alternative Routing-ID Interpretation)
- Supports IDO (ID-based Ordering)
- Retimer (extension device) presence detection
- Supports TPH (TLP Processing Hints)
- Supports ACS (Access Control Services)
- Supports DPC (Downstream Port Containment)
- Supports PTM (Precision Time Measurement)
- Supports Autonomous link speed/width change
- Supports MAC controller with individual AHB bus for register (GW5AT-60)
- Two physical functions

- Supports advanced configuration options, Advanced Error Reporting (AER), and End-to-End CRC (ECRC) Advanced Error Reporting and ECRC features
- Configurable parameters: channel width, maximum payload size, FPGA logical interface speeds, reference clock frequency, base address register decoding and filtering, etc.

For further information about PCIe Controller, please refer to [IPUG1020, Arora V PCIe Controller User Guide](#).

## 2.8 MIPI D-PHY

### 2.8.1 MIPI D-PHY RX(GW5AT-138 / GW5AT-75)

GW5AT-138 provides a MIPI D-PHY RX hardcore supporting the “MIPI Alliance Standard for D-PHY Specification(V1.2)”. The dedicated D-PHY core supports MIPI DSI and CSI-2 mobile video interfaces for cameras and displays. The main features are as follows:

- High Speed RX at up to 20 Gbps (eight data lanes).
- Two MIPI Quads, One MIPI Quad supports up to four data lanes and one clock lane.
- Bidirectional Low-power (LP) mode at up to 10Mbps per lane
- Built-in HS Sync, bit and lane alignment
- 1:8 and 1:16 deserialization modes to FPGA fabric’s user interface
- Supports MIPI DSI and MIPI CSI-2 link layers

For more information on Gowin MIPI D-PHY RX, please refer to [UG296, Arora V Hardened MIPI D-PHY User Guide](#).

### 2.8.2 MIPI D-PHY (GW5AT-60)

GW5AT-60 provides a MIPI D-PHY RX/TX hardcore supporting the “MIPI Alliance Standard for D-PHY Specification(V1.2)”. The dedicated D-PHY core supports MIPI DSI and CSI-2 mobile video interfaces for cameras and displays. The main features are as follows:

- High Speed RX/TX up to 10 Gbps with four data lanes.
- One MIPI Quad, supports up to four data lanes and one clock lane.
- Bidirectional Low-power (LP) mode at up to 10Mbps per lane
- Built-in HS Sync, bit and lane alignment
- 1:8 and 1:16 deserialization modes to FPGA fabric’s user interface
- Supports MIPI DSI and MIPI CSI-2 link layers

For more information on Gowin MIPI D-PHY RX/TX, please refer to [UG296, Arora V Hardened MIPI D-PHY User Guide](#).

### 2.8.3 GPIOs Support MIPI D-PHY RX/TX (MIPI IO)

The GPIOs support MIPI IO mode. MIPI D-PHY RX/TX implemented

by using MIPI IO mode supports MIPI DSI and CSI-2 interfaces for cameras and displays in both transmit and receive modes. The support for MIPI IO mode in the GW5AT series of FPGA products is shown in the table below.

**Table 2-12 List of GW5AT series of FPGA Products that Support MIPI IO Mode**

MIPI RX/TX	GW5AT-138	GW5AT-75	GW5AT-60
MIPI RX	All Banks	All Banks	All Banks (Except JTAG Bank)
MIPI TX	-	-	All Banks (Except JTAG Bank)

The key features include:

- MIPI Alliance Standard for D-PHY Specification, Version 1.2
- High Speed RX and TX at up to 1.5Gbps per MIPI lane
- Supports multiple PHYs (if there are enough IOs available)
- Supports bidirectional low-power (LP) mode
- Supports built-in HS Sync, bit and lane alignment
- Supports MIPI D-PHY RX 1:8 and 1:16 deserialization modes
- Supports multiple IO Types: ELVDS, TLVDS, SLVS200, LVDS, and MIPI D-PHY IO

For more information, see [IPUG948, Gowin MIPI D-PHY RX TX Advance User Guide](#).

## 2.9 MIPI C-PHY (GW5AT-60)

GW5AT-60 supports the hard-core MIPI C-PHY RX and TX, featuring highly efficient data transfer rates, and is primarily suited for high-speed serial interfaces between cameras and image processors.

- MIPI Alliance Standard for C-PHY Specification, Version 1.2.
- One MIPI Quad supports up to 3 three-wire data channels and supports up to 2.5Gsps (=5.75Gbps, RX/TX) data rate per channel.
- MIPI C-PHY RX supports high-speed mode, automatic interrupt control, and data rates of 80Msps -2500Msps.
- MIPI C-PHY TX supports high speed mode with data rate of 80Msps - 2500Msps.
- Supports bi-directional low power mode with data rates up to 10Mbps
- High speed RX mode supports De-skew function
- RX supports Linear Equalizer with maximum Delta peak > 8dB
- Supports ALP mode (optional)

## 2.10 ADC

### 2.10.1 ADC (GW5AT-138 / GW5AT-75)

The GW5AT-138 / GW5AT-75 devices integrate an 8-channel 10 bits Delta-sigma analog-to-digital converter, which is a low-power, low leakage delta-sigma ADC. Combined with the programmable logic capability of the FPGA, and the integrated voltage and temperature sensing unit, the ADC can meet the internal temperature and power monitoring and data collection requirements. At the same time, the FPGA provides rich and free configurable GPIO interfaces and ADC analog signal interfaces to connect to the voltage channel of the ADC, which can meet the voltage data collection and monitoring requirements outside the chip.

Highlights of the sensor architecture include:

- □ Number of ADCs: 2
- Reference voltage source: built-in
- Bit width accuracy: 10 bits
- Sampling clock: < 2MHz
- ADC unipolar input voltage: 0~1V
- 60dB SNR
- Temperature sensor accuracy: +/-2°C
- Voltage sensor accuracy: +/-5mV

For more information on ADC, see [UG299, Arora V Analog to Digital Converter \(ADC\) User Guide](#).

### 2.10.2 ADC (GW5AT-60)

To meet different application requirements, the GW5AT-60 device integrates two types of ADCs: SARADC and ADC Sensor.

#### SARADC

The SARADC is a 13bits ADC for high-speed signal sampling, which can meet the requirement of high precision reference voltage, and is usually used in scenarios requiring high precision. The main features are as follows:

- 13bits SAR ADC with sample rates from 100K ~ 5MSPS (optional up to 10MSPS).
- Supports single-ended and differential inputs. Single-ended input signal range: 0-1V. Differential signal range: -1V ~ 1V.
- Supports off-chip reference voltage source and on-chip voltage reference source, configurable.
- SNR > 60dB. INL: +/- 2LSB; DNL: +/- 1LSB.
- Supports range calibration and bias calibration.
- Supports single and continuous sampling.

- Supports MDRP interface configuration.

**ADC Sensor**

ADC sensor is a Delta-sigma structure ADC with on-chip temperature sensing unit, which can meet the on-chip temperature monitoring and digital quantization. ADC sensor is a low-cost solution to meet the needs of lower-speed signal monitoring with an integrated reference voltage source. The deviation due to reference voltage can also be solved by auto-calibration.

The main features are as follows:

- 10bits Delta-sigma ADC with oversampled signal frequency <10MHz.
- Signal input range: 0-1V.
- Integrates on-chip reference voltage source
- Temperature detection accuracy: +/-4°C.
- Voltage detection accuracy: +/-5mV.
- Supports single and continuous sampling.
- Supports chip temperature measurement.
- Supports MDRP interface configuration.

**2.11 Clock**

The clock resources and wiring are critical for high-performance applications in FPGA. GW5AT series of FPGA products provide the global clock network (GCLK) which connects to all the registers directly. In addition to the GCLK, PLL, HCLK, DDR memory interface, and DQS, etc. are also provided.

**Figure 2-16 GW5AT-138 / GW5AT-75 Clock Resource**

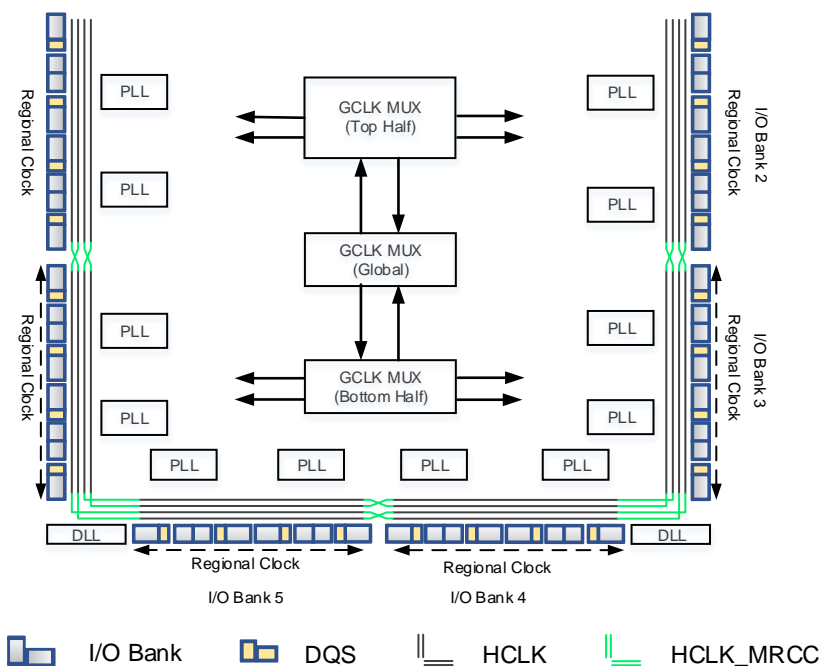
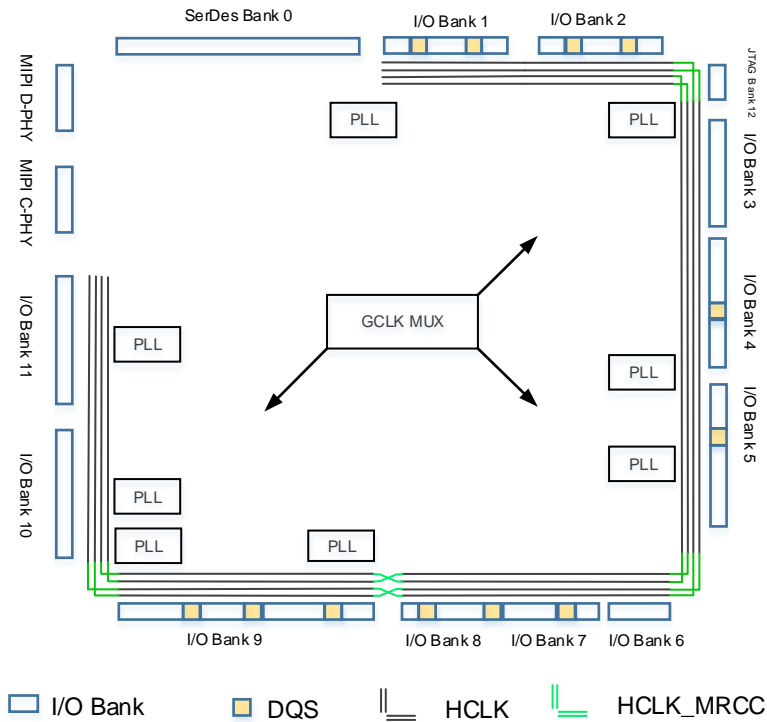

Figure 2-17 GW5AT-60 Clock Resource



Please refer to 2.11.1 ~ 2.11.4 for a brief introduction. For further detailed information on the GCLK, HCLK, DDR memory interface, and DQS, see [UG306, Arora V Clock User Guide](#).

### 2.11.1 Global Clock

GW5AT series FPGA products provide 16 global clocks. The clock source of GCLK comes from dedicated clock pins, PLL output, SerDes clock, HCLK output and common wiring resources. Dedicated clock input pins offer better clock performance and enable global driving.

### 2.11.2 HCLK

HCLK is the high-speed clock with low jitter and low skew. It can support high-performance data transfer and is mainly suitable for source synchronous data transfer protocols. One bank supports 4 HCLKs, as

shown in Figure 2-18.

**Figure 2-18 GW5AT-138 / GW5AT-75 HCLK Distribution**

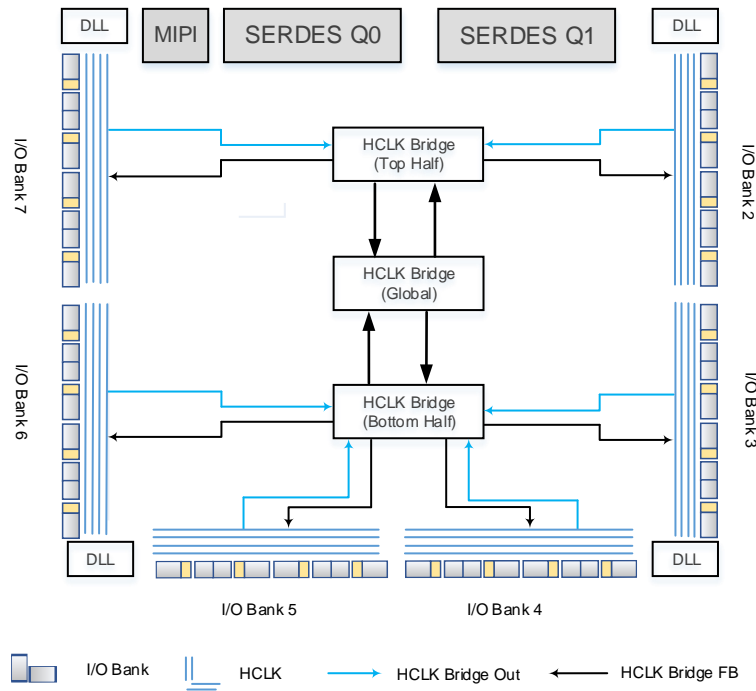

**Figure 2-19 GW5AT-60 HCLK Distribution**

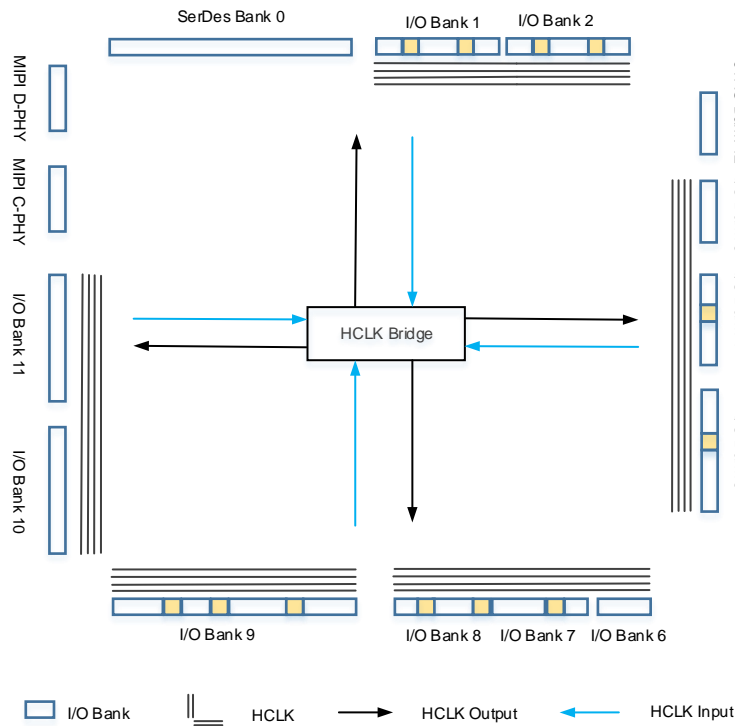

HCLK can provide users with the function modules as follows:

- Dynamic high-speed clock enable module. Able to dynamically turn on/off the high-speed clock signal.



- High speed clock frequency division module, generating a divided clock of the input clock. Used in the IO logic mode.
- Dynamic high speed clock selector.
- Dynamic delay adjustment module, producing the clock signal for the dedicated clock pin input.
- The HCLK Bridge module is able to send HCLK clock signals to any of the Banks. In addition, the HCLK clock signal can span to the clock tree of the adjacent IO Bank after entering from the IO Bank.

**Note!**

**For high speed signals of the same source, it is recommended to put them in the same IO Bank to achieve a minimum skew between signals.**

### 2.11.3 Phase-locked Loop

PLL (Phase-locked Loop) is one kind of a feedback control circuit. The frequency and phase of the internal oscillator signal is controlled by the external input reference clock.

The PLL module of the GW5AT series FPGA products can provide synthesizable clock frequencies. Frequency adjustment (multiply and division), phase adjustment, and duty cycle adjustment can be achieved by configuring the parameters.

The features of the PLL module of the GW5AT series FPGA products are as follows:

- Supports seven clock outputs
- Integer PLL, the first clock output and feedback clock output support 1/8 fractional output division
- Supports phase shift and duty cycle adjustment
- Frequency Lock detection
- Supports spread spectrum clock generation (IP required)
- VCO frequency range: 800 MHz ~ 2000 MHz
- CLKIN frequency range: 19 MHz ~ 800 MHz.

### 2.11.4 DDR Memory Interface Clock Management DQS

The DQS module of the GW5AT series of FPGA products provides the following features to support the clock requirements of the DDR memory interface:

- Receive DQS input, sort out waveform and shift 1/4 phase
- Provide a read / write pointer for input buffer
- Provide valid data for internal logic
- Provide DDR output clock signal
- Support DDR3 write voltage control

The DQS module supports multiple operating modes to meet the needs of different I/O interfaces.

### 2.11.5 Long Wire

As a supplement to CRU, the GW5AT series of FPGA products provide another routing resource- Long Wire, which is suitable for clock, clock enable, set/reset, or other high fan out signals.

## 2.12 Global Set/Reset (GSR)

A global set/reset (GSR) network is built in the GW5AT series of FPGA product. There is a direct connection to core logic. It can be used as asynchronous/synchronous set. The registers in CFU and I/O can be individually configured to use GSR.

## 2.13 Programming & Configuration

The GW5AT series of FPGA products support SRAM configuration. Each time the device is powered on, the bitstream needs to be downloaded to configure the device. Of course, you can also save the configuration data in an external Flash. After power-up, the GW5AT device loads configuration data from the external Flash into the SRAM.

Besides JTAG, the GW5AT series of FPGA products also support GOWINSEMI's own GowinCONFIG configuration mode: SSPI, MSPI, Master CPU, Slave CPU, Master SERIAL, Slave SERIAL, and PCIe (GW5AT-60). The FPGAs also support background programming, datastream file encryption and security bit setting, SEU detection and error correction, and OTP.

For more information about GW5AT-138 / GW5AT-75, please refer to [UG704, Arora V138K FPGA Products Programming and Configuration User Guide](#).

For more information about GW5AT-60, please refer to [TBD](#).

### Background Upgrade

GW5AT series of FPGAs support background upgrade by JTAG/SSPI/QSSPI or using the goConfig I<sup>2</sup>C IP / goConfig JTAG IP, that is, the device supports programming the embedded Flash or the external Flash without affecting the existing working state, the device can work Normally according to the original configuration during the programming process. And after the programming is completed, trigger RECONFIG\_N with a low level or use "Reboot" to complete the online upgrade. This feature applies to the applications requiring long online time and irregular upgrades.

### Bitstream File Encryption & Security Bit Setting

GW5AT series of FPGA products support bitstream data encryption with 128-bit AES encryption algorithm. At the same time, GOWINSEMI adds CRC and sets security bits in the bitstream file of FPGA products by default in order to guarantee the safe and accurate transmission of configuration data. During the data configuration process, the input data is verified in real time for errors, and the device cannot be woken up by incorrect data. After the configuration of the bitstream with security bit is

complete, data readback cannot be performed.

#### SEU Handler (GW5AT-138 / GW5AT-75)

The configuration SRAM of GW5AT series of FPGA products integrates a SEU handler module, which supports configuration memory soft error recovery (CMSE) and are mainly used for data detection and correction of the FPGA configuration data and are disabled by default. The features are as follows:

- Supports ECC and CRC error detection and correction. T
- The SEU function can be enabled or disabled by user logic, or the function can be enabled automatically upon program wakeup
- ECC supports 1-bit error location report and error correction<sup>[1]</sup> and 2-bit error alarm per 64-bit SRAM data

##### Note!

<sup>[1]</sup> SEU Handler can support faster error correction. Please contact your local technical support for details.

- CRC supports any bit error alarm
- Supports 1-bit error injection at any position, one error per 64-bit SRAM data
- The detection and error correction function of SRAM in this storage area will be automatically turned off when the user turns on the SSRAM storage function

#### SEU Handler (GW5AT-60)

The configuration SRAM of GW5AT series of FPGA products integrates a SEU handler module, which supports configuration memory soft error recovery (CMSE) and are mainly used for data detection and correction of the FPGA configuration data and are disabled by default. The features are as follows:

- Supports ECC and CRC error detection and correction.
- The SEU function can be enabled or disabled by user logic, or the function can be enabled automatically upon program wakeup
- ECC supports 2-bit error location report and error correction<sup>[1]</sup> and 4-bit error alarm in each SRAM Frame

##### Note!

- [1] SEU Handler can support faster error correction. Please contact your local technical support for details. CRC supports any bit error alarm
- Supports 1-bit error injection at any position, two errors in each SRAM Frame
- The detection and error correction function of SRAM in this storage area will be automatically turned off when the user turns on the SSRAM storage function

## OTP

GW5AT series of FPGA products provide a 128-bit OTP space and support one-time programming. Bit0 ~ Bit31 is the user space, which can be used to store security and other important information. Bit32~Bit95 is the DNA space, which stores the 64-bit unique identification information of the device.

## 2.14 On Chip Oscillator

There is an internal oscillator in each of the GW5AT series of FPGA products. During the configuration process, it can provide a clock for the MSPI mode. The on-chip oscillator also provides a clock resource for user designs. Up to 64 clock frequencies can be obtained by setting the parameters. The following formula is employed to get the output clock frequency:

$$f_{\text{out}}=210\text{MHz}/\text{Param}_o$$

### **Note!**

“Param” is the configuration parameter. It is 3 or an even number between 2 and 126.

# 3 AC/DC Characteristic

## Note!

You should ensure GOWINSEMI® products are always used within recommended operating conditions and range. Data beyond the working conditions and range are for reference only. GOWINSEMI® does not guarantee that all devices will operate as expected beyond the standard operating conditions and range.

## 3.1 Operating Conditions

### 3.1.1 Absolute Max. Ratings

Table 3-1 Absolute Max. Ratings (GW5AT-138 / GW5AT-75)

Name	Description	Min.	Max.
FPGA Logic			
V <sub>CC</sub> (GW5AT-138)	Core voltage	-0.5V	1.05V
V <sub>CCIO</sub>	I/O Bank voltage	-0.5V	3.75V
V <sub>CCX</sub>	Auxiliary voltage	-0.5V	1.98V
V <sub>CC_REG</sub>	Regulator voltage	-0.5V	1.98V
V <sub>IN</sub>	Single-ended input	-0.4V	3.75V
	Differential input	-0.4V	2.625V
Gigabit Transceiver			
V <sub>ddha</sub>	Analog high power supply	-0.5V	1.98V
V <sub>dda</sub>	Analog core power supply	-0.5V	1.05V
V <sub>ddd_In0~4</sub>	TX power supply	-0.5V	1.05V
MIPI			
V <sub>dda</sub>	Analog core power supply	-0.5V	1.05V
V <sub>ddx</sub>	Analog high voltage power supply	-0.5V	1.98V
V <sub>ddd</sub>	Digital core power supply	-0.5V	1.05V
Temperature			
Storage Temperature	Storage Temperature	-65 °C	+150°C
Junction Temperature	Junction Temperature	-40 °C	+125°C

Table 3-2 Absolute Max. Ratings (GW5AT-60)

Name	Description	Min.	Max.
FPGA Logic			
V <sub>CC</sub>	Core voltage, LV	-0.5V	1.05V
	Core voltage, EV	-0.5V	3.75V
V <sub>CCIO</sub>	I/O Bank voltage	-0.5V	3.75V
V <sub>CCX</sub>	Auxiliary voltage	-0.5V	3.75V
V <sub>CC_REG</sub>	Regulator voltage	-0.5V	3.75V
V <sub>IN</sub>	Single-ended input	-0.4V	3.75V
	Differential input	-0.4V	2.625V
Gigabit Transceiver			
V <sub>ddha</sub>	Analog high power supply	-0.5V	1.98V
V <sub>dda</sub>	Analog core power supply	-0.5V	1.05V
V <sub>ddd_In0~4</sub>	TX power supply	-0.5V	1.05V
MIPI			
V <sub>dda</sub>	Analog core power supply	-0.5V	1.05V
V <sub>ddx</sub>	Analog high voltage power supply	-0.5V	3.75V
V <sub>ddd</sub>	Digital core power supply	-0.5V	1.05V
Temperature			
Storage Temperature	Storage Temperature	-65 °C	+150°C
Junction Temperature	Junction Temperature	-40 °C	+125°C

### 3.1.2 Recommended Operating Conditions

Table 3-3 Recommended Range(GW5AT-138 / GW5AT-75)

Name	Description	Min.	Max.
V <sub>CC</sub> (GW5AT-138)	Core voltage	0.87V	1.0V
V <sub>CCIO</sub>	I/O Bank voltage	1V	3.465V
V <sub>CCX</sub>	Auxiliary voltage	1.71V	1.89V
V <sub>CC_REG</sub> <sup>[1]</sup>	Regulator voltage	1.14V	1.89V
Gigabit Transceiver			
V <sub>ddha</sub>	Analog high power supply	1.71V	1.89V
V <sub>dda</sub>	Analog core power supply	0.87V	1.0V
V <sub>ddd_In0~4</sub>	TX power supply	0.87V	1.0V
MIPI			
V <sub>dda</sub>	Analog core power supply	0.87V	1.0V
V <sub>ddx</sub>	Analog high voltage power supply	1.71V	1.89V
V <sub>ddd</sub>	Digital core power supply	0.87V	1.0V
Temperature			

Name	Description	Min.	Max.
T <sub>JCOM</sub>	Junction temperature Commercial operation	0 °C	+85 °C
T <sub>JIND</sub>	Junction temperature Industrial operation	-40°C	+100°C

**Note!**

- For the power supply information for different packages, please refer to UG982-GW5AT-138 Pinout.
- [1] When the VCC\_REG voltage is higher, the power consumption is higher.

**Table 3-4 Recommended Range(GW5AT-60)**

Name	Description	Min.	Max.
V <sub>CC</sub>	Core voltage, LV	0.855V	1.0V
	Core voltage, EV <sup>[1]</sup>	1.14V	1.8V
V <sub>CCIO</sub>	I/O Bank voltage	1V	3.465V
V <sub>CCX</sub>	Auxiliary voltage	2.1375V	3.465V
V <sub>CC_REG</sub>	Regulator voltage	1.14V	3.3V
<b>Gigabit Transceiver</b>			
V <sub>ddha</sub>	Analog high power supply	1.71V	1.89V
V <sub>dda</sub>	Analog core power supply	0.87V	1.0V
V <sub>ddd_In0~4</sub>	Tx power supply	0.87V	1.0V
<b>MIPI</b>			
V <sub>dda</sub>	Analog core power supply	0.87V	1.0V
V <sub>ddx</sub>	Analog high voltage power supply	2.375V	3.465V
V <sub>ddd</sub>	Digital core power supply	0.87V	1.0V
<b>Temperature</b>			
T <sub>JCOM</sub>	Junction temperature Commercial operation	0 °C	+85 °C
T <sub>JIND</sub>	Junction temperature Industrial operation	-40°C	+100°C

### 3.1.3 Power Supply Ramp Rates

**Table 3-5 Power Supply Ramp Rates**

Name	Description	Min.	Typ.	Max.
V <sub>CC</sub> Ramp	Power supply ramp rates	0.02mV/μs	TBD	50mV/μs

### 3.1.4 Hot Socket Specifications

Table 3-6 Hot Socket Specifications

Name	Description	Condition	I/O	Max.
$I_{HS}$	Input or I/O leakage current	$V_{IN}=V_{IL}$ (MAX)	I/O	150uA
$I_{HS}$	Input or I/O leakage current	$V_{IN}=V_{IL}$ (MAX)	TDI, TDO, TMS,TCK	120uA

### 3.1.5 POR Specifications

Table 3-7 POR Paramrtrs

Name	Description	Name	Typ.
POR Voltage	Power on reset voltage	$V_{CC}$	0.72V
		$V_{CCX}$	1.5V
		$V_{CCIO}$ (Bank10)	1.04V

## 3.2 ESD performance

Table 3-8 GW5AT ESD - HBM

Device	HBM
GW5AT-60	HBM $\geq$ 1000V
GW5AT-138	HBM $\geq$ 1000V
GW5AT-75	HBM $\geq$ 1000V

Table 3-9 GW5AT ESD - CDM

Device	CDM
GW5AT-60	CDM $\geq$ 500V
GW5AT-138	CDM $\geq$ 250V
GW5AT-75	CDM $\geq$ 250V



## 3.3 DC Characteristics

### 3.3.1 DC Electrical Characteristics over Recommended Operating Conditions

Table 3-10 DC Electrical Characteristics over Recommended Operating Conditions

Name	Description	Condition	Min.	Typ.	Max.
$I_{IL}, I_{IH}$	Input or I/O leakage	$V_{CCIOCCIO} < V_{IN} < V_{IH}(MAX)$	-		210uA
		$0V < V_{IN} < V_{CCIO}$	-		10uA
$I_{PU}$	I/O Active Pull-up Current	$0 < V_{IN} < 0.7V_{CCIOCCIO}$ , Pull Strength=Strong	-		-250uA
		$0 < V_{IN} < 0.7V_{CCIO}$ , Pull Strength=Medium			-150uA
		$0 < V_{IN} < 0.7V_{CCIO}$ , Pull Strength=Weak			-50uA
$I_{PD}$	I/O Active Pull-down Current	$V_{IL}(MAX) < V_{IN} < V_{CCIOCCIO}$ , Pull Strength=Strong	-		250uA
		$V_{IL}(MAX) < V_{IN} < V_{CCIOCCIO}$ , Pull Strength=Medium			150uA
		$V_{IL}(MAX) < V_{IN} < V_{CCIOCCIO}$ , Pull Strength=Weak			50uA
C1	I/O Capacitance			5pF	8pF
$V_{HYST}$	Hysteresis for Schmitt Trigger inputs	$V_{CCIOCCIO}=3.3V$ , Hysteresis=ON	-	400mV	
		$V_{CCIOCCIO}=2.5V$ , Hysteresis=ON	-	200mV	
		$V_{CCIOCCIO}=1.8V$ , Hysteresis=ON	-	100mV	
		$V_{CCIOCCIO}=1.5V$ , Hysteresis=ON	-	70mV	
		$V_{CCIOCCIO}=1.2V$ , Hysteresis=ON		40mV	

### 3.3.2 Static Current

Table 3-11 Static Current

Name	Description	LV/UV	Device	Typ. <sup>[1]</sup>
$I_{CC}$	Core Current	LV	GW5AT-138 GW5AT-75	100 mA
$I_{CCX}$	$V_{CCX}$ current ( $V_{CCX}=2.5V$ )	LV	GW5AT-138 GW5AT-75	9 mA
$I_{CCIO}$	I/O Bank current ( $V_{CCIO}=3.3V$ )	LV	GW5AT-138 GW5AT-75	5 mA
$I_{CC\_REG}$	Static Current (Built-in Regulator)	LV	GW5AT-138 GW5AT-75	6 mA

**Note!**

[1] The test condition for the typical value is 25°C.

### 3.3.3 Recommended I/O Operating Conditions

Table 3-12 I/O Operating Conditions Recommended

Name	Output $V_{CCIO}$ (V)			Input $V_{REF}$ (V)		
	Min.	Typ.	Max.	Min.	Typ.	Max.
LVTTL33	3.135	3.3	3.465	-	-	-
LVC MOS33	3.135	3.3	3.465	-	-	-
LVC MOS25	2.375	2.5	2.625	-	-	-
LVC MOS18	1.71	1.8	1.89	-	-	-
LVC MOS15	1.425	1.5	1.575	-	-	-
LVC MOS12	1.14	1.2	1.26	-	-	-
SSTL15	1.425	1.5	1.575	0.68	0.75	0.9
SSTL18_I	1.71	1.8	1.89	0.833	0.9	0.969
SSTL18_II	1.71	1.8	1.89	0.833	0.9	0.969
SSTL25_I	2.375	2.5	2.645	1.15	1.25	1.35
SSTL25_II	2.375	2.5	2.645	1.15	1.25	1.35
SSTL33_I	3.135	3.3	3.465	1.3	1.5	1.7
SSTL33_II	3.135	3.3	3.465	1.3	1.5	1.7
HSTL18_I	1.71	1.8	1.89	0.816	0.9	1.08
HSTL18_II	1.71	1.8	1.89	0.816	0.9	1.08
HSTL15	1.425	1.5	1.575	0.68	0.75	0.9
PCI33	3.135	3.3	3.465	-	-	-
LVPECL33E	3.135	3.3	3.465	-	-	-
MLVDS25E	2.375	2.5	2.625	-	-	-
BLVDS25E	2.375	2.5	2.625	-	-	-
RSDS25E	2.375	2.5	2.625	-	-	-
LVDS25E <sup>1</sup>	2.375	2.5	2.625	-	-	-
SSTL15D	1.425	1.5	1.575	-	-	-
SSTL18D_I	1.71	1.8	1.89	-	-	-
SSTL18D_II	1.71	1.8	1.89	-	-	-
SSTL25D_I	2.375	2.5	2.625	-	-	-
SSTL25D_II	2.375	2.5	2.625	-	-	-
SSTL33D_I	3.135	3.3	3.465	-	-	-
SSTL33D_II	3.135	3.3	3.465	-	-	-
HSTL15D	1.425	1.575	1.89	-	-	-
HSTL18D_I	1.71	1.8	1.89	-	-	-
HSTL18D_II	1.71	1.8	1.89	-	-	-

**Note!**

$V_{CCIO}$  of Banks with True LVDS is recommended to be set to 2.5 V.

### 3.3.4 Single ended I/O DC Characteristic

Table 3-13 Single-ended DC Characteristic

Name	$V_{IL}$		$V_{IH}$		$V_{OL}$ (Max)	$V_{OH}$ (Min)	$I_{OL}^{[1]}$ (mA)	$I_{OH}^{[1]}$ (mA)
	Min	Max	Min	Max				
LVCMOS33 LVTTL33	-0.3V	0.8V	2.0V	$V_{CCIO}+0.3$	0.4V	$V_{CCIO}-0.4V$	4	-4
							8	-8
							12	-12
							16	-16
					24	-24		
0.2V	$V_{CCIO}-0.2V$	0.1	-0.1					
LVCMOS25	-0.3V	0.7V	1.7V	$V_{CCIO}+0.3$	0.4V	$V_{CCIO}-0.4V$	4	-4
							8	-8
							12	-12
							16	-16
					24	-24		
0.2V	$V_{CCIO}-0.2V$	0.1	-0.1					
LVCMOS18	-0.3V	$0.35 \times V_{CCIO}$	$0.65 \times V_{CCIO}$	$V_{CCIO}+0.3$	0.4V	$V_{CCIO}-0.4V$	4	-4
							8	-8
							12	-12
							16	-16
					24	-24		
0.2V	$V_{CCIO}-0.2V$	0.1	-0.1					
LVCMOS15	-0.3V	$0.35 \times V_{CCIO}$	$0.65 \times V_{CCIO}$	$V_{CCIO}+0.3$	0.4V	$V_{CCIO}-0.4V$	4	-4
							8	-8
							12	-12
							16	-16
					0.2V	$V_{CCIO}-0.2V$	0.1	-0.1
LVCMOS12	-0.3V	$0.35 \times V_{CCIO}$	$0.65 \times V_{CCIO}$	$V_{CCIO}+0.3$	0.4V	$V_{CCIO}-0.4V$	4	-4
							8	-8
					12	-12		
0.2V	$V_{CCIO}-0.2V$	0.1	-0.1					
LVCMOS10	-0.3	$0.35 \times V_{CCIO}$	$0.65 \times V_{CCIO}$	1.1V	0.4V	$V_{CCIO}-0.4V$	1.5	-0.5
PCI33	-0.3V	$0.3 \times V_{CCIO}$	$0.5 \times V_{CCIO}$	$V_{CCIO}+0.3$	$0.1 \times V_{CCIO}$	$0.9 \times V_{CCIO}$	1.5	-0.5
SSTL18_II	-0.3V	$V_{REF}-0.125V$	$V_{REF}+0.125V$	$V_{CCIO}+0.3$	0.4V	$V_{CCIO}-0.4V$	13.4	-13.4
SSTL18_I	-0.3V	$V_{REF}-0.125V$	$V_{REF}+0.125V$	$V_{CCIO}+0.3$	0.40V	$V_{CCIO}-0.40V$	8	-8
SSTL15	-0.3V	$V_{REF}-0.1V$	$V_{REF}+0.1V$	$V_{CCIO}+0.3$	0.40V	$V_{CCIO}-0.40V$	13	-13

Name	V <sub>IL</sub>		V <sub>IH</sub>		V <sub>OL</sub> (Max)	V <sub>OH</sub> (Min)	I <sub>OL</sub> <sup>[1]</sup> (mA)	I <sub>OH</sub> <sup>[1]</sup> (mA)
	Min	Max	Min	Max				
SSTL135	-0.3	V <sub>REF</sub> -0.09V	V <sub>REF</sub> +0.09V	V <sub>CCIO</sub> +0.3	0.40V	V <sub>CCIO</sub> -0.40V	13	-13
HSTL18_I	-0.3V	V <sub>REF</sub> -0.1V	V <sub>REF</sub> + 0.1V	V <sub>CCIO</sub> +0.3	0.40V	V <sub>CCIO</sub> -0.40V	8	-8
HSTL18_II	-0.3V	V <sub>REF</sub> -0.1V	V <sub>REF</sub> + 0.1V	V <sub>CCIO</sub> +0.3	0.40V	V <sub>CCIO</sub> -0.40V	16	-16
HSTL15_I	-0.3V	V <sub>REF</sub> -0.1V	V <sub>REF</sub> + 0.1V	V <sub>CCIO</sub> +0.3	0.40V	V <sub>CCIO</sub> -0.40V	8	-8
HSTL15_II	-0.3V	V <sub>REF</sub> -0.1V	V <sub>REF</sub> + 0.1V	V <sub>CCIO</sub> +0.3	0.40V	V <sub>CCIO</sub> -0.40V	16	-16
HSUL12	-0.3	V <sub>REF</sub> -0.13V	V <sub>REF</sub> + 0.13V	V <sub>CCIO</sub> +0.3	0.40	V <sub>CCIO</sub> -0.40V	0.1	-0.1

**Note!**

[1] The total DC current limit (sourced and sunk) of all IOs in the same bank: the total DC current of all IOs in the same bank shall not be greater than n\*8mA, where n represents the number of IOs bonded out from a bank.

### 3.3.5 Differential I/O DC Characteristic

Table 3-14 Differential I/O DC Characteristic

Name	Description	Conditions	Min.	Typ.	Max.	Unit
V <sub>INA</sub> , V <sub>INB</sub>	Input Voltage (GW5AT-60)		-0.4		3.75	V
	Input Voltage (GW5AT-138)		-0.4		2.625	V
V <sub>CM</sub>	Input Common Mode Voltage (GW5AT-60)		0.05		2.35	V
	Input Common Mode Voltage (GW5AT-138)	Half the Sum of the Two Inputs	0.05		1.8	V
V <sub>THD</sub>	Differential Input Threshold	Difference Between the Two Inputs	±100	±350	±600	mV
I <sub>IN</sub>	Input Current	Power On or Power Off			20	μA
V <sub>OH</sub>	Output High Voltage for VOP or VOM	R <sub>T</sub> = 100Ω			1.675	V
V <sub>OL</sub>	Output High Voltage for VOP or VOM	R <sub>T</sub> = 100Ω	0.7			V
V <sub>OD</sub>	Output Voltage Differential	(V <sub>OP</sub> - V <sub>OM</sub> ), R <sub>T</sub> = 100Ω	250	350	600	mV
ΔV <sub>OD</sub>	Change in VOD Between High and Low				50	mV
V <sub>OS</sub>	Output Voltage Offset	(V <sub>OP</sub> + V <sub>OM</sub> )/2, R <sub>T</sub> = 100Ω	1.000	1.250	1.425	V
ΔV <sub>OS</sub>	Change in VOS Between High and Low				50	mV
I <sub>S</sub>	Short-circuit current	V <sub>OD</sub> = 0V two outputs shorted			12	mA

## 3.4 AC Switching Characteristics

### 3.4.1 CFU Switching Characteristics

Table 3-15 CFU Timing Parameters

Name	Description	Speed Grade		Unit
		Min	Max	
t <sub>LUT4_CFU</sub>	LUT4 delay	-	-	ns
t <sub>SR_CFU</sub>	Set/Reset to Register output	-	-	ns
t <sub>CO_CFU</sub>	Clock to Register output	-	-	ns

### 3.4.2 BSRAM Switching Characteristics

Table 3-16 BSRAM Timing Parameters

Name	Description	Speed Grade		Unit
		Min	Max	
t <sub>COAD_BSRAM</sub>	Clock to output from read address/data	-	-	ns
t <sub>COOR_BSRAM</sub>	Clock to output from output register	-	-	ns

### 3.4.3 DSP Switching Characteristics

Table 3-17 DSP Timing Parameters

Name	Description	Speed Grade		Unit
		Min	Max	
t <sub>COIR_DSP</sub>	Clock to output from input register	-	-	ns
t <sub>COPR_DSP</sub>	Clock to output from Pipeline register	-	-	ns
t <sub>COOR_DSP</sub>	Clock to output from output register	-	-	ns

### 3.4.4 Gearbox Switching Characteristics

Table 3-18 GW5AT-138 / GW5AT-75 Gearbox Timing Parameters

Device	Name	Description	Max.	Unit
GW5AT-138 GW5AT-75	FMAX <sub>IDDR</sub>	1:2 Gearbox maximum serial input rate	400	Mbps
	FMAX <sub>IDES4</sub>	1:4 Gearbox maximum serial input rate	800	Mbps
	FMAX <sub>IDESx</sub>	1:8/1:10 Gearbox maximum serial input rate	1500	Mbps
	FMAX <sub>IDES14</sub>	1:14 Gearbox maximum serial input rate	1500	Mbps
	FMAX <sub>IDES16</sub>	1:16 Gearbox maximum serial input rate	1500	Mbps
	FMAX <sub>IDES32</sub>	1:32 Gearbox maximum serial input rate	1500	Mbps
	FMAX <sub>ODDR</sub>	2:1 Gearbox maximum serial output rate	400	Mbps
	FMAX <sub>OSER4</sub>	4:1 Gearbox maximum serial output rate	800	Mbps
	FMAX <sub>OSERx</sub>	8:1/10:1 Gearbox maximum serial output rate	1500	Mbps
	FMAX <sub>OSERx</sub>	8:1/10:1 Gearbox maximum serial output rate	1500	Mbps
	FMAX <sub>OSER16</sub>	16:1 Gearbox maximum serial output rate	1500	Mbps

Table 3-19 GW5AT-60 Gearbox Timing Parameters

Device	Name	Description	Max.	Unit
GW5AT-60	FMAX <sub>IDDR</sub>	1:2 Gearbox maximum serial input rate	400	Mbps
	FMAX <sub>IDES4</sub>	1:4 Gearbox maximum serial input rate	800	Mbps
	FMAX <sub>IDESx</sub>	1:8/1:10 Gearbox maximum serial input rate	2000	Mbps
	FMAX <sub>IDES14</sub>	1:14 Gearbox maximum serial input rate	2000	Mbps
	FMAX <sub>IDES16</sub>	1:16 Gearbox maximum serial input rate	2000	Mbps
	FMAX <sub>IDES32</sub>	1:32 Gearbox maximum serial input rate	2000	Mbps
	FMAX <sub>ODDR</sub>	2:1 Gearbox maximum serial output rate	400	Mbps
	FMAX <sub>OSER4</sub>	4:1 Gearbox maximum serial output rate	800	Mbps
	FMAX <sub>OSERx</sub>	8:1/10:1 Gearbox maximum serial output rate	2000	Mbps

Device	Name	Description	Max.	Unit
	FMAX <sub>OSERx</sub>	8:1/10:1 Gearbox maximum serial output rate	2000	Mbps
	FMAX <sub>OSER16</sub>	16:1 Gearbox maximum serial output rate	2000	Mbps

### 3.4.5 Clock and I/O Switching Characteristic

Table 3-20 External Switching Characteristics

Name	Description	Device	-8		-7		Unit
			Min	Max	Min	Max	
Pin-LUT-Pin Delay <sup>(1)</sup>	Pin(IOxA) to Pin(IOxB) delay	GW5AT-138 / GW5AT-75	-	-	-	-	ns
T <sub>HCLKdly</sub>	HCLK tree delay	GW5AT-138 / GW5AT-75	-	-	-	-	ns
T <sub>GCLKdly</sub>	GCLK tree delay	GW5AT-138 / GW5AT-75	-	-	-	-	ns

### 3.4.6 On chip Oscillator Switching Characteristics

Table 3-21 On chip Oscillator Switching Characteristics

Name	Description	Min.	Typ.	Max.
f <sub>MAX</sub>	Output Frequency (0 to + 85° C)	199.5 MHz	210 MHz	220.5 MHz
	Output Frequency (-40 to +100° C)	189 MHz	210 MHz	231 MHz
t <sub>DT</sub>	Output Clock Duty Cycle	-	50%	-

### 3.4.7 PLL Switching Characteristics

Table 3-22 PLL Switching Characteristic

Device	Name	Min.	Max.
GW5AT-138 / GW5AT-75	CLKIN	19 MHz	800 MHz
	PFD	19 MHz	400 MHz
	VCO	800 MHz	1600MHz
	CLKOUT	6.25MHz <sup>[1]</sup>	1 GHz
GW5AT-60	CLKIN	19MHz	800MHz
	PFD	19MHz	400MHz
	VCO	800MHz	1600MHz
	CLKOUT	6.25MHz <sup>[1]</sup>	1600MHz

**Note!**

6.25MHz is the minimum frequency of CLKOUT in non-cascaded mode.

## 3.5 Gigabit Transceiver Performance

### 3.5.1 Transceiver Performance

Table 3-23 Transmitter and Receiver Data Rate Performance

Name/Description	Condition	Transceiver Speed Grade			Unit
		1	2	3	
On board application(chip to chip) <sup>1</sup>	Max. data rate(typical Voltage)	–	12.5	–	Gbps
	Min. data rate <sup>3</sup>	–	125	–	Mbps
Backplane <sup>2</sup>	Max. data rate(typical Voltage)	–	8	–	Gbps
	Min. data rate <sup>4</sup>	–	125	–	Mbps

**Note!**

- [1] Less channel loss for chip-chip applications.
- [2] For backplane applications, the maximum channel loss should be within PCIE 3.0 standard.
- [3] [4] The oversampling logic should be enabled.

### 3.5.2 Transceiver PLL Performance

Table 3-24 Transceiver PLL Performance

Name/Description	Condition	SpeedGrade-2		Unit
		Min	Max	
Quad PLL 0	Working range	1.25	6.5	GHz
Quad PLL 1	Working range	3.8	6.5	GHz
Channel PLL	Working range	1.25	6.5	GHz

## 3.6 Configuration Interface Timing Specification

The GW5AT series of FPGA Products support multiple GowinCONFIG modes: SSPI, MSPI, SERIAL and CPU. For further detailed information, please refer to [UG704, Arora V 138K FPGA Products Programming and Configuration Guide](#).



# 4 Ordering Information

## 4.1 Part Name

Figure 4-1 Part Naming Examples-ES

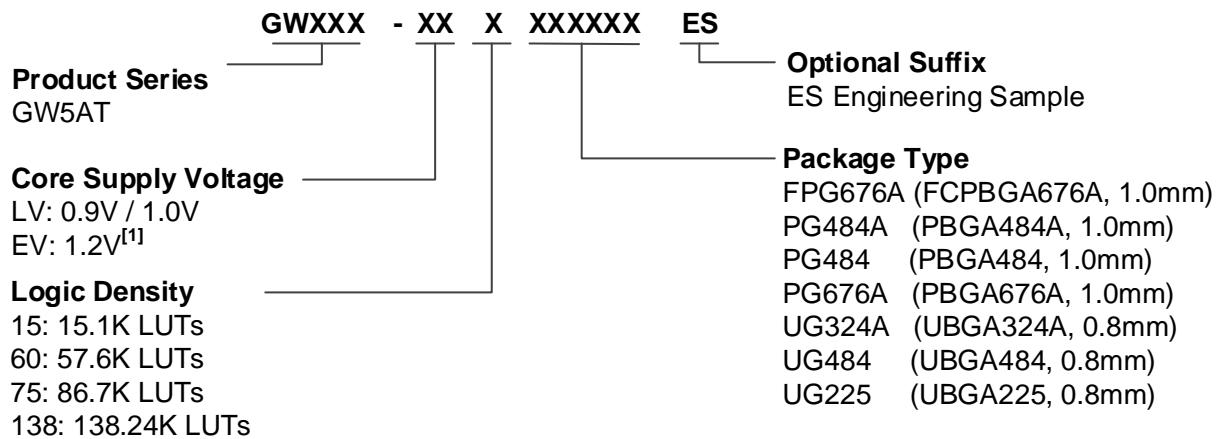

**Note!**

[1] Currently, GW5AT-60 supports the EV version.

Figure 4-2 Part Naming Examples-Production

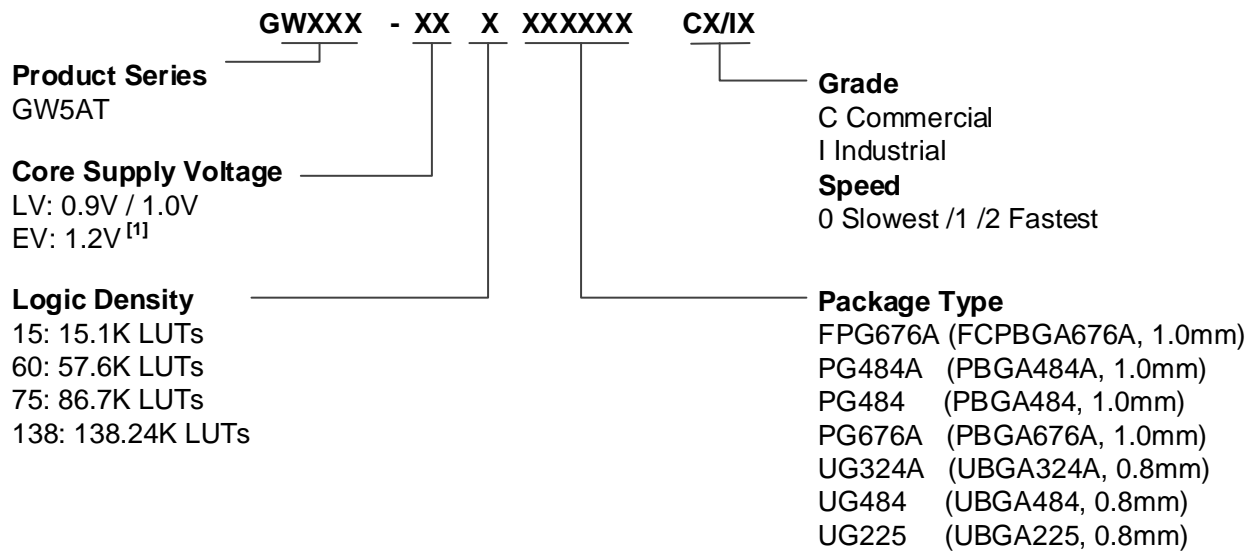

**Note!**

- [1] Currently, GW5AT-60 supports the EV version.
- For the further detailed information about the package information, please refer to 1.2 Product Resources > Table 1-2 GW5AT-138 Package Information.
- The LittleBee® family devices and Arora family devices of the same speed grade have different speeds.
- Both “C” and “I” are used in GOWIN part name marking for one device, such as C2/I1, C1/I0, etc. GOWIN devices are screened using industrial standards, so one same device can be used for both industrial (I) and commercial (C) applications. The maximum temperature of the industrial grade is 100°C, and the maximum temperature of the commercial grade is 85°C. Therefore, if the same chip meets the speed grade 2 in the commercial grade application, the speed grade is 1 in the industrial grade application.

## 4.2 Package Mark

The device information of GOWINSEMI is marked on the chip surface, as shown in Figure 4-3.

Figure 4-3 Package Mark Examples

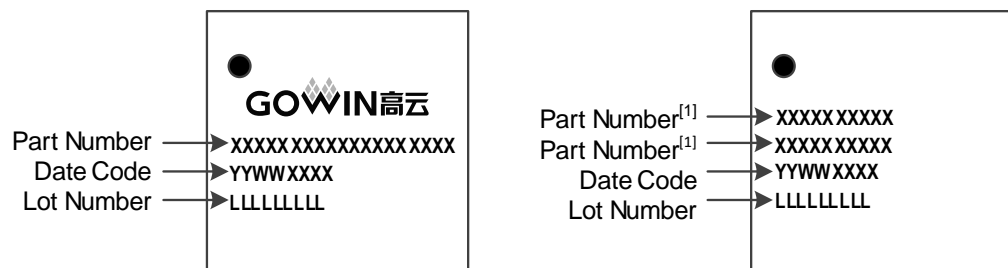

**Note!**

[1] The first two lines in the right figure above are the “Part Number”.

# 5 About This Guide

## 5.1 Purpose

This data sheet describes the features, product resources, structure, AC/DC characteristics, and the ordering information of the GW5AT series of FPGA products, making it easier to understand the GW5AT series of FPGA products and select and use our devices.

## 5.2 Related Documents

The latest user guides are available on the GOWINSEMI Website. You can find the related documents at [www.gowinsemi.com](http://www.gowinsemi.com):

- [UG704, Arora V 138K FPGA Products Programming and Configuration User Guide](#)
- [UG714, Arora V 25K FPGA Products Programming and Configuration User Guide](#)
- [UG983, GW5AT series of FPGA Products Package and Pinout Manual](#)
- [UG982, GW5AT-138 Pinout](#)
- [UG1221, GW5AT-75 Pinout](#)
- [UG984, GW5AT & GW5AST series of FPGA Products Schematic Manual](#)

## 5.3 Terminology and Abbreviations

The terminology and abbreviations used in this manual are as shown in Table 5-1.

Table 5-1 Terminology and Abbreviations

Terminology and Abbreviations	Full Name
ADC	Analog to Digital Converter
AER	Advanced Error Reporting
ALU	Arithmetic Logic Unit
BSRAM	Block Static Random Access Memory
CFU	Configurable Function Unit

Terminology and Abbreviations	Full Name
CLS	Configurable Logic Slice
CMSE	Configuration Memory Soft Error Recovery
CRU	Configurable Routing Unit
CSI	Camera Serial Interface
CTC	Clock Tolerance Compensation
CTLE	Continuous Time Linear Equalizer
DCS	Dynamic Clock Selector
DFF	D Flip-flop
DNA	Device Identifier
DP	True Dual Port 16K BSRAM
DSI	Display Serial Interface
DSP	Digital Signal Processing
ECC	Error Correction Code
ECRC	End-to-End Cyclic Redundancy Check
ESD	Electro-Static Discharge
FIFO	First In First Out
FPG	FCPBGA
FPGAs	Field Programmable Gate Array
GCLK	Global Clock
GPIO	Gowin Programmable IO
GSR	Global Set/Reset
HCLK	High Speed Clock
IOB	Input/Output Block
LUT	Look-up Table
LW	Long Wire
MIPI	Mobile Industry Processor Interface
OTP	One Time Programmable
PCIe	Peripheral Component Interface Express
PCS	Physical Coding Sublayer
PLL	Phase-locked Loop
PMA	Physical Medium Attachment Sublayer
REG	Register
SDP	Semi Dual Port 16K BSRAM
SP	Single Port 16K BSRAM
SSRAM	Shadow Static Random Access Memory
TDM	Time Division Multiplexing

## 5.4 Support and Feedback

Gowin Semiconductor provides customers with comprehensive technical support. If you have any questions, comments, or suggestions, please feel free to contact us directly using the information provided below.

Website: [www.gowinsemi.com](http://www.gowinsemi.com)

E-mail: [support@gowinsemi.com](mailto:support@gowinsemi.com)

# Preliminary

