



Gowin 原语用户指南

SUG283-2.6, 2021-07-22

版权所有 © 2021 广东高云半导体科技股份有限公司

GOWIN高云、、Gowin、GowinSynthesis、小蜜蜂、晨熙以及高云均为广东高云半导体科技股份有限公司注册商标，本手册中提到的其他任何商标，其所有权利属其拥有者所有。未经本公司书面许可，任何单位和个人都不得擅自摘抄、复制、翻译本档内容的部分或全部，并不得以任何形式传播。

免责声明

本文档并未授予任何知识产权的许可，并未以明示或暗示，或以禁止发言或其它方式授予任何知识产权许可。除高云半导体在其产品的销售条款和条件中声明的责任之外，高云半导体概不承担任何法律或非法律责任。高云半导体对高云半导体产品的销售和 / 或使用不作任何明示或暗示的担保，包括对产品的特定用途适用性、适销性或对任何专利权、版权或其它知识产权的侵权责任等，均不作担保。高云半导体对文档中包含的文字、图片及其它内容的准确性和完整性不承担任何法律或非法律责任，高云半导体保留修改文档中任何内容的权利，恕不另行通知。高云半导体不承诺对这些文档进行适时的更新。

版本信息

日期	版本	说明
2017/04/20	1.0	初始版本。
2017/09/19	1.1	<ul style="list-style-type: none"> ● 增加支持器件系列 GW1NR-4、GW1N-6、GW1N-9、GW1NR-9; ● 增加 ELVDS_Iobuf、TLVDS_Iobuf、BUFG、BUFS、OSC、IEM; ● 更新 DSP 原语; ● 更新 ODDR/ODDRc、IDDR_MEM、IDES4_MEM、IDES8_MEM、RAM16S1、RAM16S2、RAM16S4、RAM16SDP1、RAM16SDP2、RAM16SDP4、ROM16 部分 port 名称; ● 更新 OSC、PLL、DLLDLy 部分 Attribute; ● 更新部分原语例化; ● 增加 MIPI_IBUF_HS, MIPI_IBUF_LP, MIPI_OBUF, IDES16, OSER16; ● 更新 CLKDIV 部分 Attribute。
2018/04/12	1.2	增加 vhdI 原语例化。
2018/08/08	1.3	<ul style="list-style-type: none"> ● 增加支持器件系列 GW1N-2B、GW1N-4B、GW1NR-4B、GW1N-6ES、GW1N-9ES、GW1NR-9ES、GW1NS-2、GW1NS-2C; ● 增加 I3C_Iobuf、DHCEN; ● 增加 User Flash; ● 增加 EMPU; ● 更新原语名称。
2018/10/26	1.4	<ul style="list-style-type: none"> ● 增加支持器件系列 GW1NZ-1、GW1NSR-2C; ● 增加 OSCZ、FLASH96KZ。
2018/11/15	1.5	<ul style="list-style-type: none"> ● 增加支持器件系列 GW1NSR-2; ● 删除器件 GW1N-6ES、GW1N-9ES、GW1NR-9ES。
2019/01/26	1.6	<ul style="list-style-type: none"> ● CLKDIV 的 8 分频新增支持 GW1NS-2 器件; ● 删除 TLVDS_TBUF/OBUF 支持器件中的 GW1N-1。
2019/02/25	1.7	删除 TLVDS_Iobuf 支持器件中的 GW1N-1。
2019/05/20	1.8	<ul style="list-style-type: none"> ● 增加支持器件系列 GW1N-1S; ● 增加 MIPI_IBUF; ● 增加 OSCH; ● 增加 SPMI; ● 增加 I3C; ● 更新 OSC 的支持器件。
2019/10/20	1.9	更新 IOB、BSRAM、CLOCK 模块。
2019/11/28	2.0	<ul style="list-style-type: none"> ● 增加 GSR、INV 等 Miscellaneous 模块; ● 更新支持器件信息; ● 增加 FLASH64KZ, 删除 FLASH96KZ。
2020/01/16	2.1	<ul style="list-style-type: none"> ● 增加 IODELAYA、rPLL、PLLVR、CLKDIV2;

日期	版本	说明
		<ul style="list-style-type: none"> ● 增加 DPB/DPX9B、SDPB/SDPX9B、rSDP/rSDPX9、rROM/rROMX9、pROM/pROMX9; ● 增加 EMCU、BANDGAP、FLASH64K; ● 更新 IODELAY、PLL、CLKDIV、OSC、DQCE; ● 增加 FF、LATCH 放置规则; ● 增加支持器件 GW2A-55C; ● GW1N-6/GW1N-9/GW1NR-9 禁掉 DP/DPX9、DPB/DPX9B; ● IOLOGIC 增加 register 说明备注; ● GW1NZ-1 禁掉 DP/DPB 的 1,2,4,8 位宽, DPX9/DPX9 的 9 位宽。
2020/03/09	2.2	<ul style="list-style-type: none"> ● GW1NS-2、GW1NS-2C、GW1NSR-2、GW1NSR-2C、GW1NSE-2C 禁掉 DP/DPX9、DPB/DPX9B; ● OSCF 补充 OSCEN 端口说明; ● 更新 PLL/rPLL/PLLVR 参数说明。
2020/06/08	2.3	<ul style="list-style-type: none"> ● 删除器件 GW1N-2、GW1N-2B、GW1N-6; ● 增加器件 GW1N-9C、GW1NR-9C; ● 增加 IODELAYC、DHCENC、DCC; ● 增加 MIPI_IBUF 功能描述。 ● 删除 MIPI_IBUF_HS、MIPI_IBUF_LP、DLL; ● 增加 LUT5、MUX8 端口示意图; ● 增加 VCC、GND; ● 更新 PLLVR、FLASH64K、BUFS、EMPU、CLKDIV2 原语介绍; ● 删除 DP/DPX9、ROM/ROMX9、SDP/SDPX9、rSDP/rSDPX9、rROM/rROMX9、PLL; ● 调整 Iologic 结构顺序, 统一端口示意图标题名称。
2020/09/11	2.4	添加 ADC, BANDGAP, SPMI, I3C 模块 IP 调用说明。
2020/12/30	2.5	更新第二章 CFU 描述。
2021/07/22	2.6	<ul style="list-style-type: none"> ● 增加 activeFlash; ● 更新 IP 调用部分结构图, 去掉 help 内容; ● 增加器件 GW1NZ-1C、GW1N-2、GW1N-2B、GW1N-1P5、GW1N-1P5B、GW1NR-2、GW1NR-2B。

目录

目录.....	i
图目录.....	ii
表目录.....	iii
1 IOB.....	1
2 CFU.....	2
3 Memory.....	3
4 DSP.....	4
5 Clock.....	5
6 User Flash.....	6
7 EMPU.....	7
7.1 MCU.....	7
7.2 EMCU.....	20
7.3 USB20_PHY.....	32
7.4 ADC.....	42
8 其它.....	46
8.1 GSR.....	46
8.2 INV.....	47
8.3 VCC.....	48
8.4 GND.....	48
8.5 BANDGAP.....	49
8.6 SPMI.....	52
8.7 I3C.....	57
8.8 activeFlash.....	65

图目录

图 7-1 MCU 端口示意图	8
图 7-2 EMCU 端口示意图	21
图 7-3 USB20_PHY 端口示意图	33
图 7-4 ADC 端口示意图	42
图 7-5 ADC 的 IP Customization 窗口结构	44
图 8-1 GSR 端口示意图	46
图 8-2 INV 端口示意图	47
图 8-3 VCC 端口示意图	48
图 8-4 GND 端口示意图	49
图 8-5 BANDGAP 端口示意图	50
图 8-6 BandGap 的 IP Customization 窗口结构	51
图 8-7 SPMI 端口示意图	52
图 8-8 SPMI 的 IP Customization 窗口结构	55
图 8-9 I3C 端口示意图	57
图 8-10 I3C 的 IP Customization 窗口结构	64
图 8-11 activeFlash 端口示意图	65

表目录

表 7-1 MCU 适用器件	7
表 7-2 MCU 端口介绍	9
表 7-3 EMCU 适用器件	20
表 7-4 EMCU 端口介绍	22
表 7-5 USB20_PHY 适用器件	32
表 7-6 USB20_PHY 端口介绍	33
表 7-7 USB20_PHY 参数介绍	35
表 7-8 ADC 适用器件	42
表 7-9 ADC 端口介绍	42
表 8-1 GSR 端口介绍	46
表 8-2 INV 端口介绍	47
表 8-3 VCC 端口介绍	48
表 8-4 GND 端口介绍	49
表 8-5 BANDGAP 适用器件	49
表 8-6 BANDGAP 端口介绍	50
表 8-7 SPMI 适用器件	52
表 8-8 SPMI 端口介绍	52
表 8-9 I3C 适用器件	57
表 8-10 I3C 端口介绍	57
表 8-11 activeFlash 适用器件	65
表 8-12 activeFlash 端口介绍	65

1 IOB

IOB 主要包括输入输出缓存(IO Buffer)、输入输出逻辑(IO Logic)，其中 IO Buffer 及 IO Logic 原语可参考 [UG289](#)，Gowin 可编程通用管脚(GPIO)用户指南。

2 CFU

可配置功能单元(CFU)和可配置逻辑单元(CLU)是构成高云半导体 FPGA 产品内核的两种基本单元,每个基本单元可由四个可配置逻辑块(CLS)以及相应的可配置布线单元(CRU)组成。CLU 中的可配置逻辑块不能配置为静态随机存储器,可配置为基本查找表、算术逻辑单元和只读存储器。CFU 中的可配置逻辑块可根据应用场景配置成基本查找表、算术逻辑单元、静态随机存储器和只读存储器四种工作模式。CFU 原语可参考 [UG288](#), Gowin 可配置功能单元(CFU)用户指南。

3 Memory

高云半导体 **FPGA** 产品提供了丰富的存储器资源，包括块状静态随机存储器（**BSRAM**）和附加静态随机存储器（**SSRAM**）。**BSRAM/SSRAM** 原语可参考 [UG285](#)，**Gowin 存储器(BSRAM & SSRAM)**用户指南。

4 DSP

高云半导体 FPGA 产品具有丰富的 DSP 资源，可满足用户对高性能数字信号的处理需求。DSP 原语可参考 [UG287](#)，Gowin 数字信号处理器(DSP) 用户指南。

5 Clock

高云半导体 FPGA 产品提供了专用全局时钟网络(GCLK, 包括 PCLK 和 SCLK), 直接连接到器件的所有资源。除了 GCLK 资源, 还提供了锁相环 (PLL)、高速时钟 HCLK 和 DDR 存储器接口数据脉冲时钟 DQS 等时钟资源。CLOCK 原语可参考 [UG286](#), Gowin 时钟资源(Clock)用户指南。

6 User Flash

Gowin 小蜜蜂®家族 FPGA 产品提供用户闪存资源 (User Flash)，不同系列器件支持不同容量大小的 Flash。FLASH 原语可参考 [UG295](#), Gowin 闪存资源(User Flash)用户指南。

7 EMPU

7.1 MCU

原语介绍

MCU(ARM Cortex-M3 Microcontroller Unit)是一款基于 ARM Cortex-M3 的微处理器。采用了 32 位 AHB/APB 的总线模式。其内部实现了 2 个 UART、2 个 Timer 和 Watchdog 的功能。并且对外提供 16 位 GPIO、2 个 UART、JTAG、2 个 User Interrupt 接口，以及 AHB Flash 读取接口、AHB Sram 读写接口，同时对外还提供了 2 个 AHB 总线扩展接口和 1 个 APB 总线扩展接口。

适用器件

表 7-1 MCU 适用器件

家族	系列	器件
小蜜蜂 [®]	GW1NS	GW1NS-2C
	GW1NSE	GW1NSE-2C
	GW1NSR	GW1NSR-2C

端口示意图

图 7-1 MCU 端口示意图

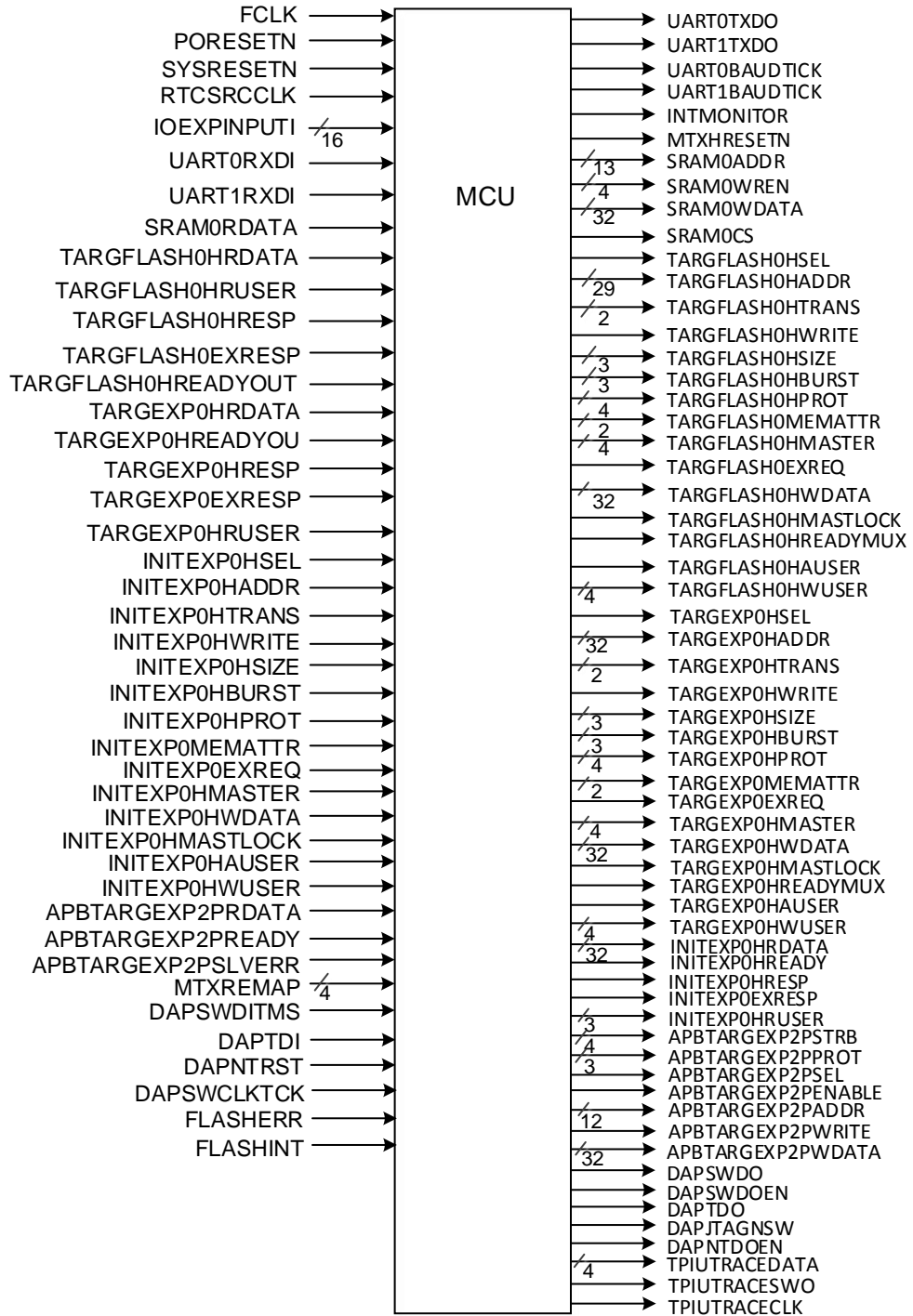

端口介绍

表 7-2 MCU 端口介绍

端口	I/O	描述
FCLK	input	Free running clock
PORESETN	input	Power on reset
SYSRESETN	input	System reset
RTCSRCLK	input	Used to generate RTC clock
IOEXPINPUTI[15:0]	input	IOEXPINPUTI
UART0RXDI	input	UART0RXDI
UART1RXDI	input	UART1RXDI
SRAM0RDATA[31:0]	input	SRAM Read data bus
TARGFLASH0HRDATA[31:0]	input	TARGFLASH0, HRDATA
TARGFLASH0HRUSER[2:0]	input	TARGFLASH0, HRUSER
TARGFLASH0HRESP	input	TARGFLASH0, HRESP
TARGFLASH0EXRESP	input	TARGFLASH0, EXRESP
TARGFLASH0HREADYOUT	input	TARGFLASH0, EXRESP
TARGEXP0HRDATA[31:0]	input	TARGEXP0, HRDATA
TARGEXP0HREADYOUT	input	TARGEXP0, HREADY
TARGEXP0HRESP	input	TARGEXP0, HRESP
TARGEXP0EXRESP	input	TARGEXP0, EXRESP
TARGEXP0HRUSER[2:0]	input	TARGEXP0, HRUSER
INITEXP0HSEL	input	INITEXP0, HSELx
INITEXP0HADDR[31:0]	input	INITEXP0, HADDR
INITEXP0HTRANS[1:0]	input	INITEXP0, HTRANS
INITEXP0HWRITE	input	INITEXP0, HWRITE
INITEXP0HSIZE[2:0]	input	INITEXP0, HSIZE
INITEXP0HBURST[2:0]	input	INITEXP0, HBURST
INITEXP0HPROT[3:0]	input	INITEXP0, HPROT
INITEXP0MEMATTR[1:0]	input	INITEXP0, MEMATTR
INITEXP0EXREQ	input	INITEXP0, EXREQ
INITEXP0HMASTER[3:0]	input	INITEXP0, HMASTER
INITEXP0HWDATA[31:0]	input	INITEXP0, HWDATA
INITEXP0HMASTLOCK	input	INITEXP0, HMASTLOCK
INITEXP0HAUSER	input	INITEXP0, HAUSER
INITEXP0HWUSER[3:0]	input	INITEXP0, HWUSER
APBTARGEXP2PRDATA[31:0]	input	APBTARGEXP2, PRDATA
APBTARGEXP2PREADY	input	APBTARGEXP2, PREADY
APBTARGEXP2PSLVERR	input	APBTARGEXP2, PSLVERR
MTXREMAP[3:0]	input	The MTXREMAP signals control the remapping of the boot memory range.

端口	I/O	描述
DAPSWDITMS	input	Debug TMS
DAPTDI	input	Debug TDI
DAPNTRST	input	Test reset
DAPSWCLKTCK	input	Test clock / SWCLK
FLASHERR	input	Output clock, used by the TPA to sample the other pins
FLASHINT	input	Output clock, used by the TPA to sample the other pins
IOEXPOUTPUTO[15:0]	output	IOEXPOUTPUTO
IOEXPOUTPUTENO[15:0]	output	IOEXPOUTPUTENO
UART0TXDO	output	UART0TXDO
UART1TXDO	output	UART1TXDO
UART0BAUDTICK	output	UART0BAUDTICK
UART1BAUDTICK	output	UART1BAUDTICK
INTMONITOR	output	INTMONITOR
MTXHRESETN	output	SRAM/Flash Chip reset
SRAM0ADDR[12:0]	output	SRAM address
SRAM0WREN[3:0]	output	SRAM Byte write enable
SRAM0WDATA[31:0]	output	SRAM Write data
SRAM0CS	output	SRAM Chip select
TARGFLASH0HSEL	output	TARGFLASH0, HSELx
TARGFLASH0HADDR[28:0]	output	TARGFLASH0, HADDR
TARGFLASH0HTRANS[1:0]	output	TARGFLASH0, HTRANS
TARGFLASH0HWRITE	output	TARGFLASH0, HWRITE
TARGFLASH0HSIZE[2:0]	output	TARGFLASH0, HSIZE
TARGFLASH0HBURST[2:0]	output	TARGFLASH0, HBURST
TARGFLASH0HPROT[3:0]	output	TARGFLASH0, HPROT
TARGFLASH0MEMATTR[1:0]	output	TARGFLASH0, MEMATTR
TARGFLASH0EXREQ	output	TARGFLASH0, EXREQ
TARGFLASH0HMASTER[3:0]	output	TARGFLASH0, HMASTER
TARGFLASH0HWDATA[31:0]	output	TARGFLASH0, HWDATA
TARGFLASH0HMASTLOCK	output	TARGFLASH0, HMASTLOCK
TARGFLASH0HREADYMUX	output	TARGFLASH0, HREADYOUT
TARGFLASH0HAUSER	output	TARGFLASH0, HAUSER
TARGFLASH0HWUSER[3:0]	output	TARGFLASH0, HWUSER
TARGEXP0HSEL	output	TARGEXP0, HSELx
TARGEXP0HADDR[31:0]	output	TARGEXP0, HADDR
TARGEXP0HTRANS[1:0]	output	TARGEXP0, HTRANS
TARGEXP0HWRITE	output	TARGEXP0, HWRITE
TARGEXP0HSIZE[2:0]	output	TARGEXP0, HSIZE
TARGEXP0HBURST[2:0]	output	TARGEXP0, HBURST
TARGEXP0HPROT[3:0]	output	TARGEXP0, HPROT

端口	I/O	描述
TARGEXP0MEMATTR[1:0]	output	TARGEXP0, MEMATTR
TARGEXP0EXREQ	output	TARGEXP0, EXREQ
TARGEXP0HMASTER[3:0]	output	TARGEXP0, HMASTER
TARGEXP0HWDATA[31:0]	output	TARGEXP0, HWDATA
TARGEXP0HMASTLOCK	output	TARGEXP0, HMASTLOCK
TARGEXP0HREADYMUX	output	TARGEXP0, HREADYOUT
TARGEXP0HAUSER	output	TARGEXP0, HAUSER
TARGEXP0HWUSER[3:0]	output	TARGEXP0, HWUSER
INITEXP0HRDATA[31:0]	output	INITEXP0, HRDATA
INITEXP0HREADY	output	INITEXP0, HREADY
INITEXP0HRESP	output	INITEXP0, HRESP
INITEXP0EXRESP	output	INITEXP0, EXRESP
INITEXP0HRUSER[2:0]	output	INITEXP0, HRUSER
APBTARGEXP2PSTRB[3:0]	output	APBTARGEXP2, PSTRB
APBTARGEXP2PPROT[2:0]	output	APBTARGEXP2, PPROT
APBTARGEXP2PSEL	output	APBTARGEXP2, PSELx
APBTARGEXP2PENABLE	output	APBTARGEXP2, PENABLE
APBTARGEXP2PADDR[11:0]	output	APBTARGEXP2, PADDR
APBTARGEXP2PWRITE	output	APBTARGEXP2, PWRITE
APBTARGEXP2PWDATA[31:0]	output	APBTARGEXP2, PWDATA
DAPSWDO	output	Serial Wire Data Out
DAPSWDOEN	output	Serial Wire Output Enable
DAPTDO	output	Debug TDO
DAPJTAGNSW	output	JTAG or Serial-Wire selection JTAG mode(1) or SW mode(0)
DAPNTDOEN	output	TDO output pad control signal
TPIUTRACEDATA[3:0]	output	Output data
TPIUTRACESWO	output	Serial Wire Viewer data
TPIUTRACECLK	output	Output clock, used by the TPA to sample the other pins

原语例化

Verilog 例化:

```
MCU u_sse050_top_syn (
.FCLK(fclk),
.PORESETN(poresetn),
.SYSRESETN(sysresetn),
.RTCSRCLK(rtsrcclk),
.IOEXPINPUTI(ioexpinputi[15:0]),
```

.IOEXPOUTPUTO(ioexpoutputo[15:0]),
.IOEXPOUTPUTENO(ioexpoutputeno[15:0]),
.UART0RXDI(uart0rxdi),
.UART0TXDO(uart0txdo),
.UART1RXDI(uart1rxdi),
.UART1TXDO(uart1txdo),
.SRAM0RDATA(sram0rdata[31:0]),
.SRAM0ADDR(sram0addr[12:0]),
 .SRAM0WREN(sram0wren[3:0]),
 .SRAM0WDATA(sram0wdata[31:0]),
 .SRAM0CS(sram0cs),
 .MTXHRESETN(mtxhreset),
 .TARGFLASH0HSEL(targflash0hsel),
 .TARGFLASH0HADDR(targflash0haddr[28:0]),
 .TARGFLASH0HTRANS(targflash0htrans[1:0]),
 .TARGFLASH0HWRITE(targflash0hwrite),
 .TARGFLASH0HSIZE(targflash0hsize[2:0]),
 .TARGFLASH0HBURST(targflash0hburst[2:0]),
 .TARGFLASH0HPROT(targflash0hprot[3:0]),
 .TARGFLASH0MEMATTR(targflash0memattr[1:0]),
 .TARGFLASH0EXREQ(targflash0exreq),
 .TARGFLASH0HMASTER(targflash0hmaster[3:0]),
 .TARGFLASH0HWDATA(targflash0hwdata[31:0]),
 .TARGFLASH0HMASTLOCK(targflash0hmastlock),
 .TARGFLASH0HREADYMUX(targflash0hreadymux),
 .TARGFLASH0HAUSER(targflash0hauser),
 .TARGFLASH0HWUSER(targflash0hwuser[3:0]),
 .TARGFLASH0HRDATA(targflash0hrdata[31:0]),
 .TARGFLASH0HRUSER(targflash0hruser[2:0]),
 .TARGFLASH0HRESP(targflash0hresp),
 .TARGFLASH0EXRESP(targflash0exresp),
 .TARGFLASH0HREADYOUT(targflash0hreadyout),
 .TARGEXP0HSEL(targexp0hsel),
 .TARGEXP0HADDR(targexp0haddr[31:0]),
 .TARGEXP0HTRANS(targexp0htrans[1:0]),
 .TARGEXP0HWRITE(targexp0hwrite),
 .TARGEXP0HSIZE(targexp0hsize[2:0]),
 .TARGEXP0HBURST(targexp0hburst[2:0]),

.TARGEXP0HPROT(targexp0hprot[3:0]),
.TARGEXP0MEMATTR(targexp0memattr[1:0]),
.TARGEXP0EXREQ(targexp0exreq),
.TARGEXP0HMASTER(targexp0hmaster[3:0]),
.TARGEXP0HWDATA(targexp0hwdata[31:0]),
.TARGEXP0HMASTLOCK(targexp0hmastlock),
.TARGEXP0HREADYMUX(targexp0hreadymux),
.TARGEXP0HAUSER(targexp0hauser),
.TARGEXP0HWUSER(targexp0hwuser[3:0]),
.TARGEXP0HRDATA(targexp0hrdata[31:0]),
.TARGEXP0HREADYOUT(targexp0hreadyout),
.TARGEXP0HRESP(targexp0hresp),
.TARGEXP0EXRESP(targexp0exresp),
.TARGEXP0HRUSER(targexp0hruser[2:0]),
.INITEXP0HSEL(initexp0hsel),
.INITEXP0HADDR(initexp0haddr[31:0]),
.INITEXP0HTRANS(initexp0htrans[1:0]),
.INITEXP0HWRITE(initexp0hwrite),
.INITEXP0HSIZE(initexp0hsize[2:0]),
.INITEXP0HBURST(initexp0hburst[2:0]),
.INITEXP0HPROT(initexp0hprot[3:0]),
.INITEXP0MEMATTR(initexp0memattr[1:0]),
.INITEXP0EXREQ(initexp0exreq),
.INITEXP0HMASTER(initexp0hmaster[3:0]),
.INITEXP0HWDATA(initexp0hwdata[31:0]),
.INITEXP0HMASTLOCK(initexp0hmastlock),
.INITEXP0HAUSER(initexp0hauser),
.INITEXP0HWUSER(initexp0hwuser[3:0]),
.INITEXP0HRDATA(initexp0hrdata[31:0]),
.INITEXP0HREADY(initexp0hready),
.INITEXP0HRESP(initexp0hresp),
.INITEXP0EXRESP(initexp0exresp),
.INITEXP0HRUSER(initexp0hruser[2:0]),
.APBTARGEXP2PSEL(apbtargexp2psel),
.APBTARGEXP2PENABLE(apbtargexp2penable),
.APBTARGEXP2PADDR(apbtargexp2paddr[11:0]),
.APBTARGEXP2PWRITE(apbtargexp2pwrite),
.APBTARGEXP2PWDATA(apbtargexp2pwdata[31:0]),

```

.APBTARGEXP2PRDATA(apbtargexp2prdata[31:0]),
.APBTARGEXP2PREADY(apbtargexp2pready),
.APBTARGEXP2PSLVERR(apbtargexp2pslverr),
.APBTARGEXP2PSTRB(apbtargexp2pstrb[3:0]),
.APBTARGEXP2PPROT(apbtargexp2pprot[2:0]),
.MTXREMAP(mtxremap[3:0]),
.DAPSWDITMS(dapswditms),
.DAPSWDO(dapswdo),
.DAPSWDOEN(dapswdoen),
.DAPTDI(daptdi),
.DAPTDO(daptdo),
.DAPNTRST(dapntrst),
.DAPSWCLKTCK(dapswclk_tck),
.DAPNTDOEN(dapntdoen),
.DAPJTAGNSW(dapjtagns),
.TPIUTRACEDATA(tpiutracedata[3:0]),
.TPIUTRACESWO(tpiutraceswo),
.TPIUTRACECLK(tpiutraceclk),
.FLASHERR(flasherr),
.FLASHINT(flashint)
);

```

Vhdl 例化:

```

COMPONENT MCU
  PORT(
    FCLK:IN std_logic;
    PORESETN:IN std_logic;
    SYSRESETN:IN std_logic;
    RTCSRCLK:IN std_logic;
    UART0RXDI:IN std_logic;
    UART1RXDI:IN std_logic;
    CLK:IN std_logic;
    RESET:IN std_logic;
    IOEXPINPUTI:IN std_logic_vector(15 downto 0);
    SRAM0RDATA:IN std_logic_vector(31 downto 0);
    TARGFLASH0HRDATA:IN std_logic_vector(31 downto 0);
    TARGFLASH0HRUSER:IN std_logic_vector(2 downto 0);
    TARGFLASH0HRESP:IN std_logic;
    TARGFLASH0EXRESP:IN std_logic;

```

TARGFLASH0HREADYOUT:IN std_logic;
TARGEXP0HRDATA: IN std_logic_vector(31 downto 0);
TARGEXP0HREADYOUT:IN std_logic;
TARGEXP0HRESP:IN std_logic;
TARGEXP0EXRESP:IN std_logic;
TARGEXP0HRUSER: IN std_logic_vector(2 downto 0);
INITEXP0HSEL:IN std_logic;
INITEXP0HADDR: IN std_logic_vector(31 downto 0);
INITEXP0HTRANS: IN std_logic_vector(1 downto 0);
INITEXP0HWRITE: IN std_logic;
INITEXP0HSIZE: IN std_logic_vector(2 downto 0);
INITEXP0HBURST: IN std_logic_vector(2 downto 0);
INITEXP0HPROT: IN std_logic_vector(3 downto 0);
INITEXP0MEMATTR: IN std_logic_vector(1 downto 0);
INITEXP0EXREQ: IN std_logic;
INITEXP0HMASTER: IN std_logic_vector(3 downto 0);
INITEXP0HWDATA: IN std_logic_vector(31 downto 0);
INITEXP0HMASTLOCK: IN std_logic;
INITEXP0HAUSER: IN std_logic;
INITEXP0HWUSER: IN std_logic_vector(3 downto 0);
APBTARGEXP2PRDATA: IN std_logic_vector(3 downto 0);
APBTARGEXP2PREADY: IN std_logic;
APBTARGEXP2PSLVERR: IN std_logic;
MTXREMAP: IN std_logic_vector(3 downto 0);
DAPSWDITMS: IN std_logic;
DAPTDI: IN std_logic;
DAPNTRST: IN std_logic;
DAPSWCLKTCK: IN std_logic;
FLASHERR: IN std_logic;
FLASHINT: IN std_logic;
IOEXPOUTPUTO:OUT std_logic_vector(15 downto 0);
IOEXPOUTPUTENO:OUT std_logic_vector(15 downto 0);
IOEXPINPUTI:OUT std_logic_vector(15 downto 0);
UART0TXDO: OUT std_logic;
UART1TXDO: OUT std_logic;
UART0BAUDTICK: OUT std_logic;
UART1BAUDTICK: OUT std_logic;
INTMONITOR: OUT std_logic;

MTXHRESETN: OUT std_logic;
SRAM0ADDR:OUT std_logic_vector(12 downto 0);
SRAM0WREN:OUT std_logic_vector(3 downto 0);
SRAM0WDATA:OUT std_logic_vector(31 downto 0);
SRAM0CS: OUT std_logic;
TARGFLASH0HSEL: OUT std_logic;
TARGFLASH0HWRITE: OUT std_logic;
TARGFLASH0EXREQ: OUT std_logic;
TARGFLASH0HMASTLOCK: OUT std_logic;
TARGFLASH0HREADYMUX: OUT std_logic;
TARGFLASH0HAUSER: OUT std_logic;
SRAM0RDATA:OUT std_logic_vector(31 downto 0);
TARGFLASH0HADDR:OUT std_logic_vector(28 downto 0);
TARGFLASH0HTRANS:OUT std_logic_vector(1 downto 0);
TARGFLASH0HSIZE:OUT std_logic_vector(2 downto 0);
TARGFLASH0HBURST:OUT std_logic_vector(2 downto 0);
TARGFLASH0HPROT:OUT std_logic_vector(3 downto 0);
TARGFLASH0MEMATTR:OUT std_logic_vector(1 downto 0);
TARGFLASH0HMASTER:OUT std_logic_vector(3 downto 0);
TARGFLASH0HWDATA:OUT std_logic_vector(31 downto 0);
TARGFLASH0HWUSER:OUT std_logic_vector(3 downto 0);
TARGFLASH0HRDATA:OUT std_logic_vector(31 downto 0);
TARGEXP0HADDR:OUT std_logic_vector(31 downto 0);
TARGEXP0HSEL: OUT std_logic;
TARGEXP0HWRITE: OUT std_logic;
TARGEXP0EXREQ: OUT std_logic;
TARGEXP0HMASTLOCK: OUT std_logic;
TARGEXP0HREADYMUX: OUT std_logic;
TARGEXP0HAUSER: OUT std_logic;
INITEXP0HREADY: OUT std_logic;
INITEXP0HRESP: OUT std_logic;
INITEXP0EXRESP: OUT std_logic;
TARGEXP0HTRANS:OUT std_logic_vector(1 downto 0);
TARGEXP0HSIZE:OUT std_logic_vector(2 downto 0);
TARGEXP0HBURST:OUT std_logic_vector(2 downto 0);
TARGEXP0HPROT:OUT std_logic_vector(3 downto 0);
TARGEXP0MEMATTR:OUT std_logic_vector(1 downto 0);
TARGEXP0HMASTER:OUT std_logic_vector(3 downto 0);

```

TARGEXP0HWDATA:OUT std_logic_vector(31 downto 0);
TARGEXP0HWUSER:OUT std_logic_vector(3 downto 0);
INITEXP0HRDATA:OUT std_logic_vector(31 downto 0);
INITEXP0HRUSER:OUT std_logic_vector(2 downto 0);
APBTARGEXP2PSTRB:OUT std_logic_vector(3 downto 0);
APBTARGEXP2PPROT:OUT std_logic_vector(2 downto 0);
APBTARGEXP2PADDR:OUT std_logic_vector(11 downto 0);
APBTARGEXP2PWDATA:OUT std_logic_vector(31 downto 0);
TPIUTRACEDATA:OUT std_logic_vector(3 downto 0);
APBTARGEXP2PSEL: OUT std_logic;
APBTARGEXP2PENABLE: OUT std_logic;
APBTARGEXP2PWRITE: OUT std_logic;
DAPSWDO: OUT std_logic;
DAPSWDOEN: OUT std_logic;
DAPTDO: OUT std_logic;
DAPJTAGNSW: OUT std_logic;
DAPNTDOEN: OUT std_logic;
TPIUTRACESWO: OUT std_logic;
TPIUTRACECLK: OUT std_logic;
);
END COMPONENT;

```

```

uut: MCU
  PORT MAP (
    FCLK=> fclk;
    PORESETN=> poresetn;
    SYSRESETN=> sysresetn;
    RTCSRCCLK=> rtcsrcclk;
    UART0RXDI=> uart0rxdi;
    UART1RXDI=> uart1rxdi;
    CLK=>clk,
    RESET=>reset,
    IOEXPINPUTI=>ioexpinputi,
    SRAM0RDATA=>sram0rdata,
    TARGFLASH0HRDATA=>targflash0hrdata,
    TARGFLASH0HRUSER=>targflash0hruser,
    TARGFLASH0HRESP=>targflash0hresp,
    TARGFLASH0EXRESP=>targflash0exresp,

```

TARGFLASH0HREADYOUT=>targflash0hreadyout,
TARGEXP0HRDATA=>targexp0hrdata,
TARGEXP0HREADYOUT=>targexp0hreadyout,
TARGEXP0HRESP=>targexp0hresp,
TARGEXP0EXRESP=>targexp0exresp,
TARGEXP0HRUSER=>targexp0hruser,
INITEXP0HSEL=>initexp0hsel,
INITEXP0HADDR=>initexp0haddr,
INITEXP0HTRANS=>initexp0htrans,
INITEXP0HWRITE=>initexp0hwrite,
INITEXP0HSIZE=>initexp0hsize,
INITEXP0HBURST=>initexp0hburst,
INITEXP0HPROT=>initexp0hprot,
INITEXP0MEMATTR=>initexp0memattr,
INITEXP0EXREQ=>initexp0exreq,
INITEXP0HMASTER=>initexp0hmaster,
INITEXP0HWDATA=>initexp0hwdata,
INITEXP0HMASTLOCK=>initexp0hmastlock,
INITEXP0HAUSER=>initexp0hauser,
INITEXP0HWUSER=>initexp0hwuser,
APBTARGEXP2PRDATA=>apbtargexp2prdata,
APBTARGEXP2PREADY=>apbtargexp2pready,
APBTARGEXP2PSLVERR=>apbtargexp2pslverr,
MTXREMAP=>mtxremap,
DAPSWDITMS=>dapswditms,
DAPTDI=>daptidi,
DAPNTRST=>dapntrst,
DAPSWCLKTCK=>dapswclktck,
FLASHERR=>flasherr,
FLASHINT=>flashint,
IOEXPOUTPUTO=>ioexpoutputo,
IOEXPOUTPUTENO=>ioexpoutputeno,
IOEXPINPUTI=>ioexpinputi,
UART0TXDO=>uart0txdo,
UART1TXDO=>uart1txdo,
UART0BAUDTICK=>uart0baudtick,
UART1BAUDTICK=>uart1baudtick,
INTMONITOR=>intmonitor,

MTXHRESETN=>mtxhresetn,
SRAM0ADDR=>sram0addr,
SRAM0WREN=>sram0wren,
SRAM0WDATA=>sram0wdata,
SRAM0CS=>sram0cs,
TARGFLASH0HSEL=>targflash0hssel,
TARGFLASH0HWRITE=>targflash0hwrite,
TARGFLASH0EXREQ=>targflash0exreq,
TARGFLASH0HMASTLOCK=>targflash0hmastlock,
TARGFLASH0HREADYMUX=>targflash0hreadymux,
TARGFLASH0HAUSER=>targflash0hauser,
SRAM0RDATA=>sram0rdata,
TARGFLASH0HADDR=>targflash0haddr,
TARGFLASH0HTRANS=>targflash0htrans,
TARGFLASH0HSIZE=>targflash0hsize,
TARGFLASH0HBURST=>targflash0hburst,
TARGFLASH0HPROT=>targflash0hprot,
TARGFLASH0MEMATTR=>targflash0memattr,
TARGFLASH0HMASTER=>targflash0hmaster,
TARGFLASH0HWDATA=>targflash0hwdata,
TARGFLASH0HWUSER=>targflash0hwuser,
TARGFLASH0HRDATA=>targflash0hrdata,
TARGEXP0HADDR=>targexp0haddr,
TARGEXP0HSEL=>targexp0hssel,
TARGEXP0HWRITE=>targexp0hwrite,
TARGEXP0EXREQ=>targexp0exreq,
TARGEXP0HMASTLOCK=>targexp0hmastlock,
TARGEXP0HREADYMUX=>targexp0hreadymux,
TARGEXP0HAUSER=>targexp0hauser,
INITEXP0HREADY=>initexp0hready,
INITEXP0HRESP=>initexp0hresp,
INITEXP0EXRESP=>initexp0exresp,
TARGEXP0HTRANS=>targexp0htrans,
TARGEXP0HSIZE=>targexp0hsize,
TARGEXP0HBURST=>targexp0hburst,
TARGEXP0HPROT=>targexp0hprot,
TARGEXP0MEMATTR=>targexp0memattr,
TARGEXP0HMASTER=>targexp0hmaster,

```

TARGEXP0HWDATA=>targexp0hwdata,
TARGEXP0HWUSER=>targexp0hwuser,
INITEXP0HRDATA=>initexp0hrdata,
INITEXP0HRUSER=>initexp0hruser,
APBTARGEXP2PSTRB=>apbtargexp2pstrb,
APBTARGEXP2PPROT=>apbtargexp2pprot,
APBTARGEXP2PADDR=>apbtargexp2paddr,
APBTARGEXP2PWDATA=>apbtargexp2pwwdata,
TPIUTRACEDATA=>tpiutracedata,
APBTARGEXP2PSEL=>apbtargexp2psel,
APBTARGEXP2PENABLE=>apbtargexp2penable,
APBTARGEXP2PWRITE=>apbtargexp2pwrite,
DAPSWDO=>dapswdo,
DAPSWDOEN=>dapswdoen,
DAPTDO=>daptdo,
DAPJTAGNSW=>dapjtagns,
DAPNTDOEN=>dapntdoen,
TPIUTRACESWO=>tpiutraceswo,
TPIUTRACECLK=>tpiutracedclk );

```

7.2 EMCU

原语介绍

EMCU(ARM Cortex-M3 Microcontroller Unit)是一款基于 ARM Cortex-M3 的微处理器。采用了 32 位 AHB/APB 的总线模式。其内部实现了 2 个 UART、2 个 Timer 和 Watchdog 的功能。并且对外提供 16 位 GPIO、2 个 UART、JTAG、6 个 User Interrupt 接口。以及 AHB Flash 读取接口、AHB Sram 读写接口。同时对外还提供了 2 个 AHB 总线扩展接口和 1 个 APB 总线扩展接口。EMCU 增强了中断处理能力,改善了 FLASH 接口,提高了 MCU 运行主频。

适用器件

表 7-3 EMCU 适用器件

家族	系列	器件
小蜜蜂®	GW1NS	GW1NS-4C
	GW1NSR	GW1NSR-4C
	GW1NSER	GW1NSER-4C

端口示意图

图 7-2 EMCU 端口示意图

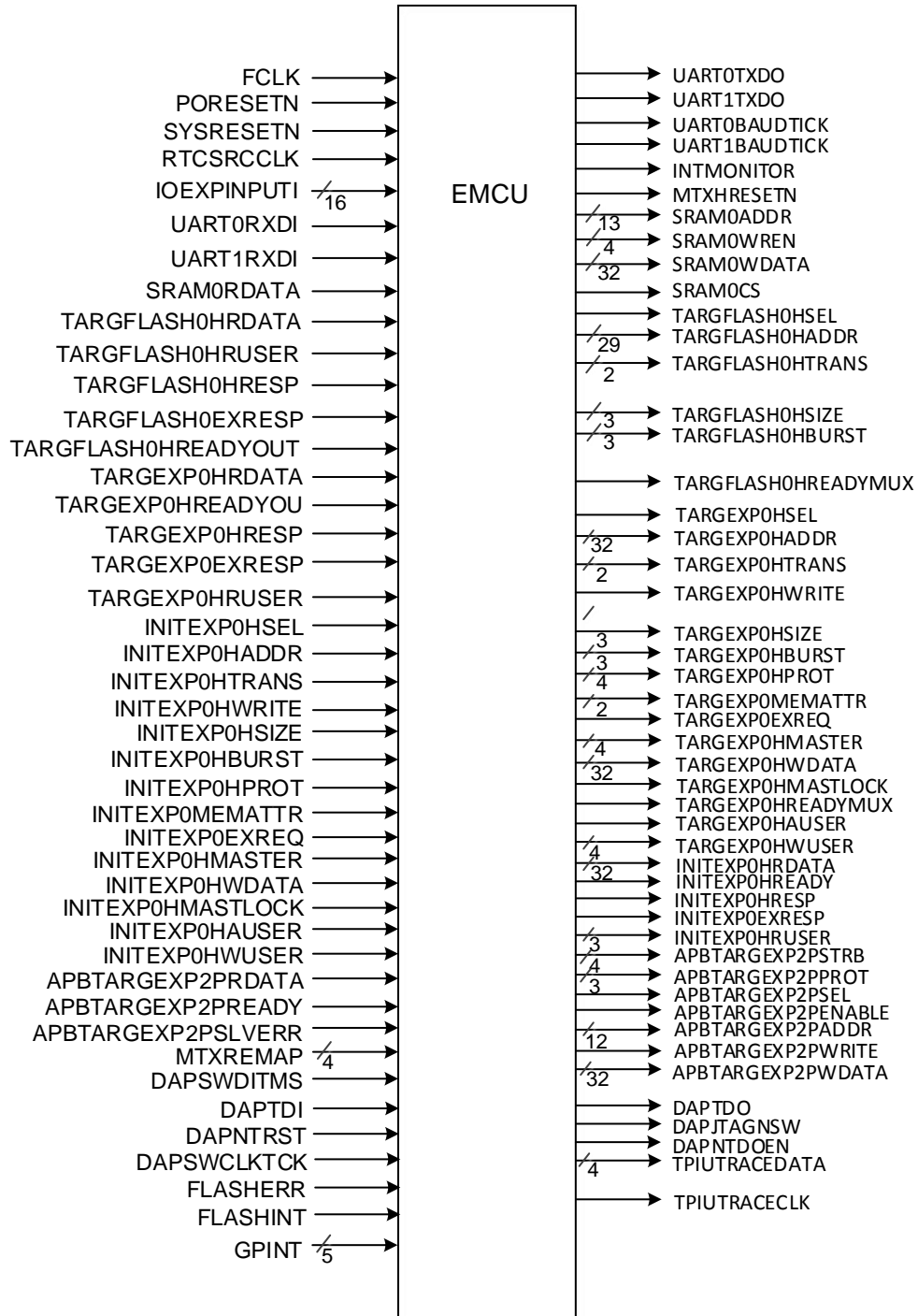

端口介绍

表 7-4 EMCU 端口介绍

端口	I/O	描述
FCLK	input	Free running clock
PORESETN	input	Power on reset
SYSRESETN	input	System reset
RTCSRCLK	input	Used to generate RTC clock
IOEXPINPUTI[15:0]	input	IOEXPINPUTI
UART0RXDI	input	UART0RXDI
UART1RXDI	input	UART1RXDI
SRAM0RDATA[31:0]	input	SRAM Read data bus
TARGFLASH0HRDATA[31:0]	input	TARGFLASH0, HRDATA
TARGFLASH0HRUSER[2:0]	input	TARGFLASH0, HRUSER
TARGFLASH0HRESP	input	TARGFLASH0, HRESP
TARGFLASH0EXRESP	input	TARGFLASH0, EXRESP
TARGFLASH0HREADYOUT	input	TARGFLASH0, EXRESP
TARGEXP0HRDATA[31:0]	input	TARGEXP0, HRDATA
TARGEXP0HREADYOUT	input	TARGEXP0, HREADY
TARGEXP0HRESP	input	TARGEXP0, HRESP
TARGEXP0EXRESP	input	TARGEXP0, EXRESP
TARGEXP0HRUSER[2:0]	input	TARGEXP0, HRUSER
INITEXP0HSEL	input	INITEXP0, HSELx
INITEXP0HADDR[31:0]	input	INITEXP0, HADDR
INITEXP0HTRANS[1:0]	input	INITEXP0, HTRANS
INITEXP0HWRITE	input	INITEXP0, HWRITE
INITEXP0HSIZE[2:0]	input	INITEXP0, HSIZE
INITEXP0HBURST[2:0]	input	INITEXP0, HBURST
INITEXP0HPROT[3:0]	input	INITEXP0, HPROT
INITEXP0MEMATTR[1:0]	input	INITEXP0, MEMATTR
INITEXP0EXREQ	input	INITEXP0, EXREQ
INITEXP0HMASTER[3:0]	input	INITEXP0, HMASTER
INITEXP0HWDATA[31:0]	input	INITEXP0, HWDATA
INITEXP0HMASTLOCK	input	INITEXP0, HMASTLOCK
INITEXP0HAUSER	input	INITEXP0, HAUSER
INITEXP0HWUSER[3:0]	input	INITEXP0, HWUSER
APBTARGEXP2PRDATA[31:0]	input	APBTARGEXP2, PRDATA
APBTARGEXP2PREADY	input	APBTARGEXP2, PREADY
APBTARGEXP2PSLVERR	input	APBTARGEXP2, PSLVERR
MTXREMAP[3:0]	input	The MTXREMAP signals control the remapping of the boot memory range.

端口	I/O	描述
DAPSWDITMS	input	Debug TMS
DAPTDI	input	Debug TDI
DAPNTRST	input	Test reset
DAPSWCLKTCK	input	Test clock / SWCLK
FLASHERR	input	Output clock, used by the TPA to sample the other pins
FLASHINT	input	Output clock, used by the TPA to sample the other pins
GPINT	input	GPINT
IOEXPOUTPUTO[15:0]	output	IOEXPOUTPUTO
IOEXPOUTPUTENO[15:0]	output	IOEXPOUTPUTENO
UART0TXDO	output	UART0TXDO
UART1TXDO	output	UART1TXDO
UART0BAUDTICK	output	UART0BAUDTICK
UART1BAUDTICK	output	UART1BAUDTICK
INTMONITOR	output	INTMONITOR
MTXHRESETN	output	SRAM/Flash Chip reset
SRAM0ADDR[12:0]	output	SRAM address
SRAM0WREN[3:0]	output	SRAM Byte write enable
SRAM0WDATA[31:0]	output	SRAM Write data
SRAM0CS	output	SRAM Chip select
TARGFLASH0HSEL	output	TARGFLASH0, HSELx
TARGFLASH0HADDR[28:0]	output	TARGFLASH0, HADDR
TARGFLASH0HTRANS[1:0]	output	TARGFLASH0, HTRANS
TARGFLASH0HSIZE[2:0]	output	TARGFLASH0, HSIZE
TARGFLASH0HBURST[2:0]	output	TARGFLASH0, HBURST
TARGFLASH0HREADYMUX	output	TARGFLASH0, HREADYOUT
TARGEXP0HSEL	output	TARGEXP0, HSELx
TARGEXP0HADDR[31:0]	output	TARGEXP0, HADDR
TARGEXP0HTRANS[1:0]	output	TARGEXP0, HTRANS
TARGEXP0HWRITE	output	TARGEXP0, HWRITE
TARGEXP0HSIZE[2:0]	output	TARGEXP0, HSIZE
TARGEXP0HBURST[2:0]	output	TARGEXP0, HBURST
TARGEXP0HPROT[3:0]	output	TARGEXP0, HPROT
TARGEXP0MEMATTR[1:0]	output	TARGEXP0, MEMATTR
TARGEXP0EXREQ	output	TARGEXP0, EXREQ
TARGEXP0HMASTER[3:0]	output	TARGEXP0, HMASTER
TARGEXP0HWDATA[31:0]	output	TARGEXP0, HWDATA
TARGEXP0HMASTLOCK	output	TARGEXP0, HMASTLOCK
TARGEXP0HREADYMUX	output	TARGEXP0, HREADYOUT
TARGEXP0HAUSER	output	TARGEXP0, HAUSER
TARGEXP0HWUSER[3:0]	output	TARGEXP0, HWUSER

端口	I/O	描述
INITEXP0HRDATA[31:0]	output	INITEXP0, HRDATA
INITEXP0HREADY	output	INITEXP0, HREADY
INITEXP0HRESP	output	INITEXP0, HRESP
INITEXP0EXRESP	output	INITEXP0, EXRESP
INITEXP0HRUSER[2:0]	output	INITEXP0, HRUSER
APBTARGEXP2PSTRB[3:0]	output	APBTARGEXP2, PSTRB
APBTARGEXP2PPROT[2:0]	output	APBTARGEXP2, PPROT
APBTARGEXP2PSEL	output	APBTARGEXP2, PSELx
APBTARGEXP2PENABLE	output	APBTARGEXP2, PENABLE
APBTARGEXP2PADDR[11:0]	output	APBTARGEXP2, PADDR
APBTARGEXP2PWRITE	output	APBTARGEXP2, PWRITE
APBTARGEXP2PWDATA[31:0]	output	APBTARGEXP2, PWDATA
DAPTDO	output	Debug TDO
DAPJTAGNSW	output	JTAG or Serial-Wire selection JTAG mode(1) or SW mode(0)
DAPNTDOEN	output	TDO output pad control signal
TPIUTRACEDATA[3:0]	output	Output data
TPIUTRACECLK	output	Output clock, used by the TPA to sample the other pins

原语例化

Verilog 例化:

```

MCU u_sse050_top_syn (
.FCLK(fclk),
.PORESETN(poresetn),
.SYSRESETN(sysresetn),
.RTCSRCLK(rtsrcclk),
.IOEXPINPUTI(ioexpinputi[15:0]),
.IOEXPOUTPUTO(ioexpoutputo[15:0]),
.IOEXPOUTPUTENO(ioexpoutputeno[15:0]),
.UART0RXDI(uart0rxdi),
.UART0TXDO(uart0txdo),
.UART1RXDI(uart1rxdi),
.UART1TXDO(uart1txdo),
.SRAM0RDATA(sram0rdata[31:0]),
.SRAM0ADDR(sram0addr[12:0]),
.SRAM0WREN(sram0wren[3:0]),
.SRAM0WDATA(sram0wdata[31:0]),
.SRAM0CS(sram0cs),

```

.MTXHRESETN(mtxhreset),
.TARGFLASH0HSEL(targflash0hsel),
.TARGFLASH0HADDR(targflash0haddr[28:0]),
.TARGFLASH0HTRANS(targflash0htrans[1:0]),
.TARGFLASH0HSIZE(targflash0hsize[2:0]),
.TARGFLASH0HBURST(targflash0hburst[2:0]),
.TARGFLASH0HREADYMUX(targflash0hreadymux),
.TARGFLASH0HRDATA(targflash0hrdata[31:0]),
.TARGFLASH0HRUSER(targflash0hruser[2:0]),
.TARGFLASH0HRESP(targflash0hresp),
.TARGFLASH0EXRESP(targflash0exresp),
.TARGFLASH0HREADYOUT(targflash0hreadyout),
.TARGEXP0HSEL(targexp0hsel),
.TARGEXP0HADDR(targexp0haddr[31:0]),
.TARGEXP0HTRANS(targexp0htrans[1:0]),
.TARGEXP0HWRITE(targexp0hwrite),
.TARGEXP0HSIZE(targexp0hsize[2:0]),
.TARGEXP0HBURST(targexp0hburst[2:0]),
.TARGEXP0HPROT(targexp0hprot[3:0]),
.TARGEXP0MEMATTR(targexp0memattr[1:0]),
.TARGEXP0EXREQ(targexp0exreq),
.TARGEXP0HMASTER(targexp0hmaster[3:0]),
.TARGEXP0HWDATA(targexp0hwdata[31:0]),
.TARGEXP0HMASTLOCK(targexp0hmastlock),
.TARGEXP0HREADYMUX(targexp0hreadymux),
.TARGEXP0HAUSER(targexp0hauser),
.TARGEXP0HWUSER(targexp0hwuser[3:0]),
.TARGEXP0HRDATA(targexp0hrdata[31:0]),
.TARGEXP0HREADYOUT(targexp0hreadyout),
.TARGEXP0HRESP(targexp0hresp),
.TARGEXP0EXRESP(targexp0exresp),
.TARGEXP0HRUSER(targexp0hruser[2:0]),
.INITEXP0HSEL(initexp0hsel),
.INITEXP0HADDR(initexp0haddr[31:0]),
.INITEXP0HTRANS(initexp0htrans[1:0]),
.INITEXP0HWRITE(initexp0hwrite),
.INITEXP0HSIZE(initexp0hsize[2:0]),
.INITEXP0HBURST(initexp0hburst[2:0]),

```

.INITEXP0HPROT(initexp0hprot[3:0]),
.INITEXP0MEMATTR(initexp0memattr[1:0]),
.INITEXP0EXREQ(initexp0exreq),
.INITEXP0HMASTER(initexp0hmaster[3:0]),
.INITEXP0HWDATA(initexp0hwdata[31:0]),
.INITEXP0HMASTLOCK(initexp0hmastlock),
.INITEXP0HAUSER(initexp0hauser),
.INITEXP0HWUSER(initexp0hwuser[3:0]),
.INITEXP0HRDATA(initexp0hrdata[31:0]),
.INITEXP0HREADY(initexp0hready),
.INITEXP0HRESP(initexp0hresp),
.INITEXP0EXRESP(initexp0exresp),
.INITEXP0HRUSER(initexp0hruser[2:0]),
.APBTARGEXP2PSEL(apbtargexp2psel),
.APBTARGEXP2PENABLE(apbtargexp2penable),
.APBTARGEXP2PADDR(apbtargexp2paddr[11:0]),
.APBTARGEXP2PWRITE(apbtargexp2pwrite),
.APBTARGEXP2PWDATA(apbtargexp2pwwdata[31:0]),
.APBTARGEXP2PRDATA(apbtargexp2prdata[31:0]),
.APBTARGEXP2PREADY(apbtargexp2pready),
.APBTARGEXP2PSLVERR(apbtargexp2pslverr),
.APBTARGEXP2PSTRB(apbtargexp2pstrb[3:0]),
.APBTARGEXP2PPROT(apbtargexp2pprot[2:0]),
.MTXREMAP(mtxremap[3:0]),
.DAPSWDITMS(dapswditms),
.DAPTDI(daptdi),
.DAPTDO(daptdo),
.DAPNTRST(dapntrst),
.DAPSWCLKTCK(dapswclk_tck),
.DAPNTDOEN(dapntdoen),
.DAPJTAGNSW(dapjtagns),
.TPIUTRACEDATA(tpiutracedata[3:0]),
.TPIUTRACECLK(tpiutracedata),
.FLASHERR(flasherr),
.GPINT(gpint),
.FLASHINT(flashint)
);

```

Vhdl 例化:

```
COMPONENT MCU
    PORT(
    FCLK:IN std_logic;
    PORESETN:IN std_logic;
    SYSRESETN:IN std_logic;
    RTCSRCLK:IN std_logic;
    UART0RXDI:IN std_logic;
    UART1RXDI:IN std_logic;
    CLK:IN std_logic;
    RESET:IN std_logic;
    IOEXPINPUTI:IN std_logic_vector(15 downto 0);
    SRAM0RDATA:IN std_logic_vector(31 downto 0);
    TARGFLASH0HRDATA:IN std_logic_vector(31 downto 0);
    TARGFLASH0HRUSER:IN std_logic_vector(2 downto 0);
    TARGFLASH0HRESP:IN std_logic;
    TARGFLASH0EXRESP:IN std_logic;
    TARGFLASH0HREADYOUT:IN std_logic;
    TARGEXP0HRDATA: IN std_logic_vector(31 downto 0);
    TARGEXP0HREADYOUT:IN std_logic;
    TARGEXP0HRESP:IN std_logic;
    TARGEXP0EXRESP:IN std_logic;
    TARGEXP0HRUSER: IN std_logic_vector(2 downto 0);
    INITEXP0HSEL:IN std_logic;
    INITEXP0HADDR: IN std_logic_vector(31 downto 0);
    INITEXP0HTRANS: IN std_logic_vector(1 downto 0);
    INITEXP0HWRITE: IN std_logic;
    INITEXP0HSIZE: IN std_logic_vector(2 downto 0);
    INITEXP0HBURST: IN std_logic_vector(2 downto 0);
    INITEXP0HPROT: IN std_logic_vector(3 downto 0);
    INITEXP0MEMATTR: IN std_logic_vector(1 downto 0);
    INITEXP0EXREQ: IN std_logic;
    INITEXP0HMASTER: IN std_logic_vector(3 downto 0);
    INITEXP0HWDATA: IN std_logic_vector(31 downto 0);
    INITEXP0HMASTLOCK: IN std_logic;
    INITEXP0HAUSER: IN std_logic;
    INITEXP0HWUSER: IN std_logic_vector(3 downto 0);
    APBTARGEXP2PRDATA: IN std_logic_vector(3 downto 0);
    APBTARGEXP2PREADY: IN std_logic;
```

APBTARGEXP2PSLVERR: IN std_logic;
MTXREMAP: IN std_logic_vector(3 downto 0);
DAPSWDITMS: IN std_logic;
DAPTDI: IN std_logic;
DAPNTRST: IN std_logic;
DAPSWCLKTCK: IN std_logic;
FLASHERR: IN std_logic;
FLASHINT: IN std_logic;
GPINT: IN std_logic;
IOEXPOUTPUTO:OUT std_logic_vector(15 downto 0);
IOEXPOUTPUTENO:OUT std_logic_vector(15 downto 0);
IOEXPINPUTI:OUT std_logic_vector(15 downto 0);
UART0TXDO: OUT std_logic;
UART1TXDO: OUT std_logic;
UART0BAUDTICK: OUT std_logic;
UART1BAUDTICK: OUT std_logic;
INTMONITOR: OUT std_logic;
MTXHRESETN: OUT std_logic;
SRAM0ADDR:OUT std_logic_vector(12 downto 0);
SRAM0WREN:OUT std_logic_vector(3 downto 0);
SRAM0WDATA:OUT std_logic_vector(31 downto 0);
SRAM0CS: OUT std_logic;
TARGFLASH0HSEL: OUT std_logic;
TARGFLASH0HREADYMUX: OUT std_logic;
SRAM0RDATA:OUT std_logic_vector(31 downto 0);
TARGFLASH0HADDR:OUT std_logic_vector(28 downto 0);
TARGFLASH0HTRANS:OUT std_logic_vector(1 downto 0);
TARGFLASH0HSIZE:OUT std_logic_vector(2 downto 0);
TARGFLASH0HBURST:OUT std_logic_vector(2 downto 0);
TARGFLASH0HRDATA:OUT std_logic_vector(31 downto 0);
TARGEXP0HADDR:OUT std_logic_vector(31 downto 0);
TARGEXP0HSEL: OUT std_logic;
TARGEXP0HWRITE: OUT std_logic;
TARGEXP0EXREQ: OUT std_logic;
TARGEXP0HMASTLOCK: OUT std_logic;
TARGEXP0HREADYMUX: OUT std_logic;
TARGEXP0HAUSER: OUT std_logic;
INITEXP0HREADY: OUT std_logic;

```

INITEXP0HRESP: OUT std_logic;
INITEXP0EXRESP: OUT std_logic;
TARGEXP0HTRANS:OUT std_logic_vector(1 downto 0);
TARGEXP0HSIZE:OUT std_logic_vector(2 downto 0);
TARGEXP0HBURST:OUT std_logic_vector(2 downto 0);
TARGEXP0HPROT:OUT std_logic_vector(3 downto 0);
TARGEXP0MEMATTR:OUT std_logic_vector(1 downto 0);
TARGEXP0HMASTER:OUT std_logic_vector(3 downto 0);
TARGEXP0HWDATA:OUT std_logic_vector(31 downto 0);
TARGEXP0HWUSER:OUT std_logic_vector(3 downto 0);
INITEXP0HRDATA:OUT std_logic_vector(31 downto 0);
INITEXP0HRUSER:OUT std_logic_vector(2 downto 0);
APBTARGEXP2PSTRB:OUT std_logic_vector(3 downto 0);
APBTARGEXP2PPROT:OUT std_logic_vector(2 downto 0);
APBTARGEXP2PADDR:OUT std_logic_vector(11 downto 0);
APBTARGEXP2PWDATA:OUT std_logic_vector(31 downto 0);
TPIUTRACEDATA:OUT std_logic_vector(3 downto 0);
APBTARGEXP2PSEL: OUT std_logic;
APBTARGEXP2PENABLE: OUT std_logic;
APBTARGEXP2PWRITE: OUT std_logic;
DAPTD0: OUT std_logic;
DAPJTAGNSW: OUT std_logic;
DAPNTDOEN: OUT std_logic;
TPIUTRACECLK: OUT std_logic;
);
END COMPONENT;

```

```

uut: MCU
  PORT MAP (
    FCLK=> fclk;
    PORESETN=> poresetn;
    SYSRESETN=> sysresetn;
    RTCSRCLK=> rtcsrcclk;
    UART0RXDI=> uart0rxdi;
    UART1RXDI=> uart1rxdi;
    CLK=>clk,
    RESET=>reset,
    IOEXPINPUTI=>ioexpinputi,

```

SRAM0RDATA=>sram0rdata,
TARGFLASH0HRDATA=>targflash0hrdata,
TARGFLASH0HRUSER=>targflash0hruser,
TARGFLASH0HRESP=>targflash0hresp,
TARGFLASH0EXRESP=>targflash0exresp,
TARGFLASH0HREADYOUT=>targflash0hreadyout,
TARGEXP0HRDATA=>targexp0hrdata,
TARGEXP0HREADYOUT=>targexp0hreadyout,
TARGEXP0HRESP=>targexp0hresp,
TARGEXP0EXRESP=>targexp0exresp,
TARGEXP0HRUSER=>targexp0hruser,
INITEXP0HSEL=>initexp0hssel,
INITEXP0HADDR=>initexp0haddr,
INITEXP0HTRANS=>initexp0htrans,
INITEXP0HWRITE=>initexp0hwrite,
INITEXP0HSIZE=>initexp0hsize,
INITEXP0HBURST=>initexp0hburst,
INITEXP0HPROT=>initexp0hprot,
INITEXP0MEMATTR=>initexp0memattr,
INITEXP0EXREQ=>initexp0exreq,
INITEXP0HMASTER=>initexp0hmaster,
INITEXP0HWDATA=>initexp0hwdata,
INITEXP0HMASTLOCK=>initexp0hmastlock,
INITEXP0HAUSER=>initexp0hauser,
INITEXP0HWUSER=>initexp0hwuser,
APBTARGEXP2PRDATA=>apbtargexp2prdata,
APBTARGEXP2PREADY=>apbtargexp2pready,
APBTARGEXP2PSLVERR=>apbtargexp2pslverr,
MTXREMAP=>mtxremap,
DAPSWDITMS=>dapswditms,
DAPTDI=>daptidi,
DAPNTRST=>dapntrst,
DAPSWCLKTCK=>dapswclktck,
FLASHERR=>flasherr,
FLASHINT=>flashint,
GPINT=>gpint,
IOEXPOUTPUTO=>ioexpoutputo,
IOEXPOUTPUTENO=>ioexpoutputeno,

IOEXPINPUTI=>ioexpinputi,
UART0TXDO=>uart0txdo,
UART1TXDO=>uart1txdo,
UART0BAUDTICK=>uart0baudtick,
UART1BAUDTICK=>uart1baudtick,
INTMONITOR=>intmonitor,
MTXHRESETN=>mtxhresetn,
SRAM0ADDR=>sram0addr,
SRAM0WREN=>sram0wren,
SRAM0WDATA=>sram0wdata,
SRAM0CS=>sram0cs,
TARGFLASH0HSEL=>targflash0hsel,
TARGFLASH0HREADYMUX=>targflash0hreadymux,
SRAM0RDATA=>sram0rdata,
TARGFLASH0HADDR=>targflash0haddr,
TARGFLASH0HTRANS=>targflash0htrans,
TARGFLASH0HSIZE=>targflash0hsize,
TARGFLASH0HBURST=>targflash0hburst,
TARGFLASH0HRDATA=>targflash0hrdata,
TARGEXP0HADDR=>targexp0haddr,
TARGEXP0HSEL=>targexp0hsel,
TARGEXP0HWRITE=>targexp0hwrite,
TARGEXP0EXREQ=>targexp0exreq,
TARGEXP0HMASTLOCK=>targexp0hmastlock,
TARGEXP0HREADYMUX=>targexp0hreadymux,
TARGEXP0HAUSER=>targexp0hauser,
INITEXP0HREADY=>initexp0hready,
INITEXP0HRESP=>initexp0hresp,
INITEXP0EXRESP=>initexp0exresp,
TARGEXP0HTRANS=>targexp0htrans,
TARGEXP0HSIZE=>targexp0hsize,
TARGEXP0HBURST=>targexp0hburst,
TARGEXP0HPROT=>targexp0hprot,
TARGEXP0MEMATTR=>targexp0memattr,
TARGEXP0HMASTER=>targexp0hmaster,
TARGEXP0HWDATA=>targexp0hwdata,
TARGEXP0HWUSER=>targexp0hwuser,
INITEXP0HRDATA=>initexp0hrdata,

```

INITEXP0HRUSER=>initexp0hruser,
APBTARGEXP2PSTRB=>apbtargexp2pstrb,
APBTARGEXP2PPROT=>apbtargexp2pprot,
APBTARGEXP2PADDR=>apbtargexp2paddr,
APBTARGEXP2PWDATA=>apbtargexp2pwdata,
TPIUTRACEDATA=>tpiutracedata,
APBTARGEXP2PSEL=>apbtargexp2psel,
APBTARGEXP2PENABLE=>apbtargexp2penable,
APBTARGEXP2PWRITE=>apbtargexp2pwrite,
DAPTDO=>daptdo,
DAPJTAGNSW=>dapjtagns,
DAPNTDOEN=>dapntdoen,
TPIUTRACECLK=>tpiutracedata );

```

7.3 USB20_PHY

原语介绍

USB20_PHY 是完整的混合信号 IP 解决方案，实现从 Soc (System-on-Chip) 到其他特殊制造工艺的 OTG 连接。USB20_PHY 支持 USB 2.0 480-Mbps 的协议和数据速率，并且后向兼容 USB 1.1 1.5-Mbps 和 12-Mbps 的协议和数据速率。

适用器件

表 7-5 USB20_PHY 适用器件

家族	系列	器件
小蜜蜂®	GW1NS	GW1NS-2, GW1NS-2C
	GW1NSE	GW1NSE-2C
	GW1NSR	GW1NSR-2, GW1NSR-2C

端口示意图

图 7-3 USB20_PHY 端口示意图

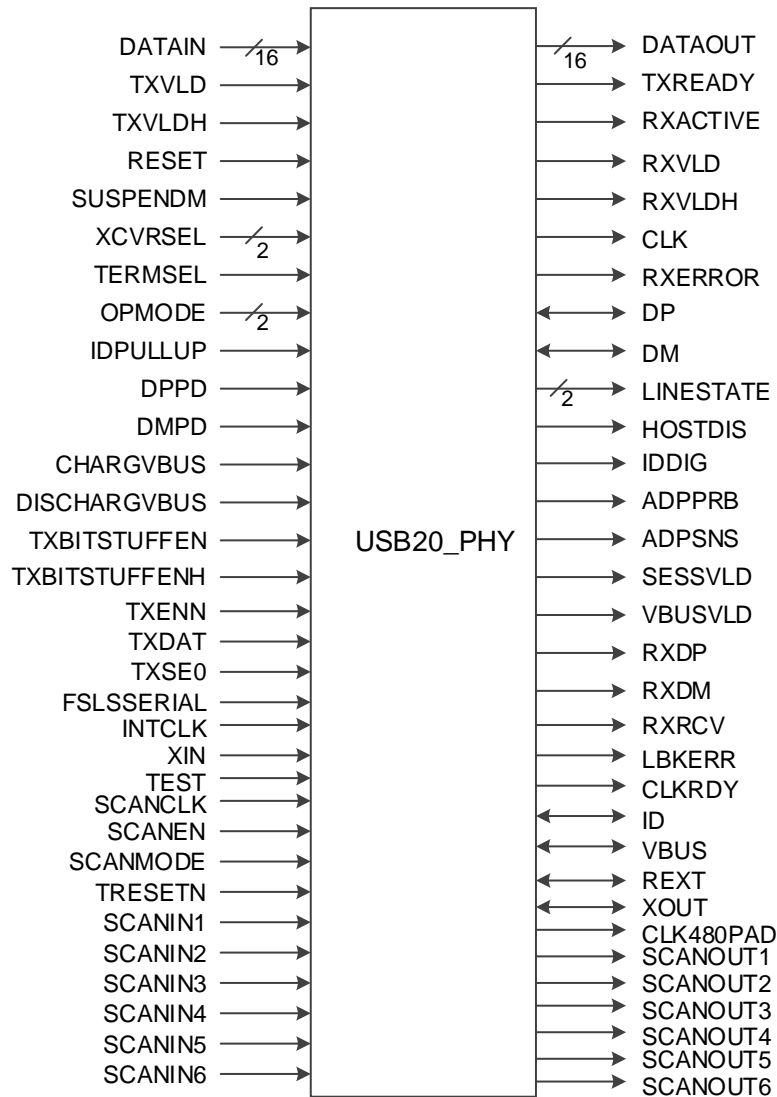

端口介绍

表 7-6 USB20_PHY 端口介绍

端口	I/O	描述
DATAIN[15:0]	input	16-bit parallel USB data input bus
TXVLD	input	Transmit Valid. Indicates that the DataIn bus is valid.
TXVLDH	input	Transmit Valid High. When DataBus16_8 = 1, this signal indicates that the DataIn[15:8] bus contains valid transmit data.
RESET	input	Reset. Reset all state machines in the UTM.
SUSPENDM	input	Suspend. 0:suspend, 1: normal
XCVRSEL[1:0]	input	Transceiver Select. This signal selects between the LS, FS and HS transceivers
TERMSEL	input	Termination Select. This signal selects between the FS and HS terminations

端口	I/O	描述
OPMODE[1:0]	input	Operational Mode. These signals select between various operational modes
IDPULLUP	input	Signal that enables the sampling of the analog Id line.
DPPD	input	This signal enables the 15k Ohm pull-down resistor on the DP line.
DMPD	input	0b : Pull-down resistor not connected to DM; 1b : Pull-down resistor connected to DM
CHARGVBUS	input	This signal enables charging Vbus
DISCHARGVBUS	input	The signal enables discharging Vbus.
TXBITSTUFFEN	input	Indicates if the data on the DataOut[7:0] lines needs to be bitstuffed or not.
TXBITSTUFFENH	input	Indicates if the data on the DataOut[15:8] lines needs to be bitstuffed or not.
TXENN	input	Active low enable signal. Only used when FsLsSerialMode is set to 1b
TXDAT	input	Differential data at D+/D- output. Only used when FsLsSerialMode is set to 1b
TXSE0	input	Force Single-Ended Zero. Only used when FsLsSerialMode is set to 1b
FSLSSERIAL	input	0b : FS and LS packets are sent using the parallel interface. 1b : FS and LS packets are sent using the serial interface.
INTCLK	input	Clock signals provided internally of the SoC
TEST	input	For IP TESTING purpose. Please leave it unconnected since there are already soft pull-down in the IP
SCANCLK	input	Clock signals for scan mode
SCANEN	input	Select to shift mode
SCANMODE	input	High effective signal to enter scan mode
TRESETN	input	Low effective RESET signal for scan mode
SCANIN1	input	Scan chain input
SCANIN2	input	Scan chain input
SCANIN3	input	Scan chain input
SCANIN4	input	Scan chain input
SCANIN5	input	Scan chain input
SCANIN6	input	Scan chain input
DP	inout	USB data pin Data+
DM	inout	USB data pin Data-
ID	inout	ID signal from the cable
VBUS	inout	Vbus signals connected with the cable
REXT	inout	12.7K High precision resistor
XIN	inout	Crystal in signals, supported range is 12MHZ~24MHZ
XOUT	inout	Crystal out signals
DATAOUT[15:0]	output	DataOut. 16-bit parallel USB data output bus.
TXREADY	output	Transmit Data Ready.
RXACTIVE	output	Receive Active. Indicates that the receive state machine has detected SYNC and is active.

端口	I/O	描述
RXVLD	output	Receive Data Valid. Indicates that the DataOut bus has valid data.
RXVLDH	output	Receive Data Valid High.
CLK	output	Clock. This output is used for clocking receive and transmit parallel data.
RXERROR	output	Receive Error.
LINESTATE[1:0]	output	Line State. These signals reflect the current state of the single ended receivers.
HOSTDIS	output	This signal is used for all types of peripherals connected to it.
IDDIG	output	Indicates whether the connected plug is a mini-A or mini-B.
ADPPRB	output	Indicates if the voltage on Vbus ($0.6V < V_{th} < 0.75V$).
ADPSNS	output	Indicates if the voltage on Vbus ($0.2V < V_{th} < 0.55V$).
SESSVLD	output	Indicates if the session for an A/B-peripheral is valid ($0.8V < V_{th} < 2V$).
VBUSVLD	output	Indicates if the voltage on Vbus is at a valid level for operation ($4.4V < V_{th} < 4.75V$)
RXDP	output	Single-ended receive data, positive terminal. This signal is only valid if FsLsSerialMode is set to 1b
RXDM	output	Single-ended receive data, negative terminal. This signal is only valid if FsLsSerialMode is set to 1b
RXRCV	output	Receive data. This signal is only valid if FsLsSerialMode is set to 1b
LBKERR	output	used for observation
CLKRDY	output	Observation/debug signal to show that the internal PLL has locked and is ready.
CLK480PAD	output	480MHZ clock output for observation
SCANOUT1	output	Scan chain output
SCANOUT2	output	Scan chain output
SCANOUT3	output	Scan chain output
SCANOUT4	output	Scan chain output
SCANOUT5	output	Scan chain output
SCANOUT6	output	Scan chain output

参数介绍

表 7-7 USB20_PHY 参数介绍

参数	默认	描述
DATABUS16_8	1'b0	Selects between 8 and 16 bit data transfers.
ADP_PRBEN	1'b0	Enables/disables the ADP Probe comparator
TEST_MODE	5'b0	used for testing and debugging purpose
HSDRV1	1'b0	High speed drive adjustment. Please connect to 0 for normal operation.
HSDRV0	1'b0	High speed drive adjustment. Please connect to 0 for normal operation.
CLK_SEL	1'b0	Clock source selection signal. 0 to select external clock provided by the crystal connected on XIN,

参数	默认	描述
		XOUT. 1 to select internal clock provided on INTCLK port
M	4'b0	M divider input data bit
N	6'b101000	N divider input data bit
C	2'b01	Control charge pump current input data bit, it supports from 30uA (00) to 60uA (11).
FOC_LOCK	1'b0	0: LOCK is generated by PLL lock detector. 1: LOCK is always high(always lock)

原语例化

Verilog 例化:

```

USB20_PHY usb20_phy_inst (
    .DATAOUT(dataout[15:0]),
    .TXREADY(txready),
    .RXACTIVE(rxactive),
    .RXVLD(rxvld),
    .RXVLDH(rxvldh),
    .CLK(clk),
    .RXERROR(rxerror),
    .DP(dp),
    .DM(dm),
    .LINESTATE(linestate[1:0]),
    .DATAIN(datain[15:0]),
    .TXVLD(txvld),
    .TXVLDH(txvldh),
    .RESET(reset),
    .SUSPENDM(suspendm),
    .XCVRSEL(xcvrsel[1:0]),
    .TERMSEL(termsel),
    .OPMODE(opmode[1:0]),
    .HOSTDIS(hostdis),
    .IDDIG(iddig),
    .ADPPRB(adpprb),
    .ADPSNS(adpsns),
    .SESSVLD(sessvld),
    .VBUSVLD(vbusvld),
    .RXDP(rxdp),
    .RXDM(rxdm),

```

.RXRCV(rxrcv),
.IDPULLUP(idpullup),
.DPPD(dppd),
.DMPD(dmpd),
.CHARGVBUS(chargvbus),
.DISCHARGVBUS(dischargvbus),
.TXBITSTUFFEN(txbitstufen),
.TXBITSTUFFENH(txbitstuffenh),
.TXENN(txenn),
.TXDAT(txdat),
.TXSE0(txse0),
.FSLSSERIAL(fslsserial),
.LBKERR(lbkerr),
.CLKRDY(clkrdy),
.INTCLK(intclk),
.ID(id),
.VBUS(vbus),
.REXT(rext),
.XIN(xin),
.XOUT(xout),
.CLK480PAD(clk480pad),
.TEST(test),
.SCANOUT1(scanout1),
.SCANOUT2(scanout2),
.SCANOUT3(scanout3),
.SCANOUT4(scanout4),
.SCANOUT5(scanout5),
.SCANOUT6(scanout6),
.SCANCLK(scanclk),
.SCANEN(scanen),
.SCANMODE(scanmode),
.TRESETN(tresetn),
.SCANIN1(scanin1),
.SCANIN2(scanin2),
.SCANIN3(scanin3),
.SCANIN4(scanin4),
.SCANIN5(scanin5),
.SCANIN6(scanin6)

```
);
defparam usb20_phy_inst.DATABUS16_8 = 1'b0;
defparam usb20_phy_inst.ADP_PRBEN = 1'b0;
defparam usb20_phy_inst.TEST_MODE = 5'b0;;
defparam usb20_phy_inst.HSDRV1 = 1'b0;
defparam usb20_phy_inst.HSDRV0 = 1'b0;
defparam usb20_phy_inst.CLK_SEL = 1'b0;
defparam usb20_phy_inst.M = 4'b0;
defparam usb20_phy_inst.N = 6'b101000;
defparam usb20_phy_inst.C = 2'b01;
defparam usb20_phy_inst.FOC_LOCK = 1'b0;
```

Vhdl 例化:

```
COMPONENT USB20_PHY
  GENERIC (
    TEST_MODE:bit_vector:="00000";
    DATABUS16_8:bit:='0';
    ADP_PRBEN:bit:='0';
    HSDRV1:bit:='0';
    HSDRV0:bit:='0';
    CLK_SEL:bit:='0';
    M:bit_vector:="0000";
    N:bit_vector:=" 101000";
    C:bit_vector:="01";
    FOC_LOCK:bit:='0';
  );
PORT(
  DATAIN:IN std_logic_vector(15 downto 0);
  TXVLD:IN std_logic;
  TXVLDH:IN std_logic;
  RESET:IN std_logic;
  SUSPENDM:IN std_logic;
  XCVRSEL:IN std_logic_vector(1 downto 0);
  TERMSEL:IN std_logic;
  OPMODE:IN std_logic_vector(1 downto 0);
  DATAOUT:OUT std_logic_vector(15 downto 0);
  TXREADY:OUT std_logic;
  RXACTIVE:OUT std_logic;
```

```
RXVLD:OUT std_logic;  
RXVLDH:OUT std_logic;  
CLK:OUT std_logic;  
RXERROR:OUT std_logic;  
DP:INOUT std_logic;  
DM:INOUT std_logic;  
LINESTATE:OUT std_logic_vector(1 downto 0);  
IDPULLUP:IN std_logic;  
DPPD:IN std_logic;  
DMPD:IN std_logic;  
CHARGVBUS:IN std_logic;  
DISCHARGVBUS:IN std_logic;  
TXBITSTUFFEN:IN std_logic;  
TXBITSTUFFENH:IN std_logic;  
TXENN:IN std_logic;  
TXDAT:IN std_logic;  
TXSE0:IN std_logic;  
FSLSSERIAL:IN std_logic;  
HOSTDIS:OUT std_logic;  
IDDIG:OUT std_logic;  
ADPPRB:OUT std_logic;  
ADPSNS:OUT std_logic;  
SESSVLD:OUT std_logic;  
VBUSVLD:OUT std_logic;  
RXDP:OUT std_logic;  
RXDM:OUT std_logic;  
RXRCV:OUT std_logic;  
LBKERR:OUT std_logic;  
CLKRDY:OUT std_logic;  
INTCLK:IN std_logic;  
ID:INOUT std_logic;  
VBUS:INOUT std_logic;  
REXT:INOUT std_logic;  
XIN:IN std_logic;  
XOUT:INOUT std_logic;  
TEST:IN std_logic;  
CLK480PAD:OUT std_logic;  
SCANCLK:IN std_logic;
```

```

        SCANEN:IN std_logic;
        SCANMODE:IN std_logic;
        TRESETN:IN std_logic;
        SCANIN1:IN std_logic;
        SCANOUT1:OUT std_logic;
        SCANIN2:IN std_logic;
        SCANOUT2:OUT std_logic;
        SCANIN3:IN std_logic;
        SCANOUT3:OUT std_logic;
        SCANIN4:IN std_logic;
        SCANOUT4:OUT std_logic;
        SCANIN5:IN std_logic;
        SCANOUT5:OUT std_logic;
        SCANIN6:IN std_logic;
        SCANOUT6:OUT std_logic;
    );
END COMPONENT;
 uut: USB20_PHY
    PORT MAP (
        DATAIN=>datain,
        TXVLD=>txvld,
        TXVLDH=>txvldh,
        RESET=>reset,
        SUSPENDM=>suspendm,
        XCVRSEL=>xcvrsel,
        TERMSEL=>termsel,
        OPMODE=>opmode,
        DATAOUT=>dataout,
        TXREADY=>txready,
        RXACTIVE=>rxactive,
        RXVLD=>rxvld,
        RXVLDH=>rxvldh,
        CLK=>clk,
        RXERROR=>rxerror,
        DP=>dp,
        DM=>dm,
        LINESTATE=>linestate,
        IDPULLUP=>idpullup,

```

DPPD=>dppd,
DMPD=>dmpd,
CHARGVBUS=>chargvbus,
DISCHARGVBUS=>dischargvbus,
TXBITSTUFFEN=>txbitstufen,
TXBITSTUFFENH=>txbitstuffenh,
TXENN=>txenn,
TXDAT=>txdat,
TXSE0=>txse0,
FSLSSERIAL=>fslsserial,
HOSTDIS=>hostdis,
IDDIG=>iddig,
ADPPRB=>adpprb,
ADPSNS=>adpsns,
SESSVLD=>sessvld,
VBUSVLD=>vbusvld,
RXDP=>rxdp,
RXDM=>rxdm,
RXRCV=>rxrcv,
LBKERR=>lbkerr,
CLKRDY=>clkrdy,
INTCLK=>intclk,
ID=>id,
VBUS=>vbus,
REXT=>rext,
XIN=>xin,
XOUT=>xout,
TEST=>test,
CLK480PAD=>clk480pad,
SCANCLK=>scanclk,
SCANEN=>scanen,
SCANMODE=>scanmode,
TRESETN=>tresetn,
SCANIN1=>scanin1,
SCANOUT1=>scanout1,
SCANIN2=>scanin2,
SCANOUT2=>scanout2,
SCANIN3=>scanin3,

```

SCANOUT3=>scanout3,
SCANIN4=>scanin4,
SCANOUT4=>scanout4,
SCANIN5=>scanin5,
SCANOUT5=>scanout5,
SCANIN6=>scanin6,
SCANOUT6=>scanout6

```

```
);
```

7.4 ADC

原语介绍

ADC (Analog-to-digital Converter) 是一个 8 通道单端 12 位的模数转换器，具有低功耗、低漏电和高动态特性。

适用器件

表 7-8 ADC 适用器件

家族	系列	器件
小蜜蜂®	GW1NS	GW1NS-2, GW1NS-2C
	GW1NSE	GW1NSE-2C
	GW1NSR	GW1NSR-2, GW1NSR-2C

端口示意图

图 7-4 ADC 端口示意图

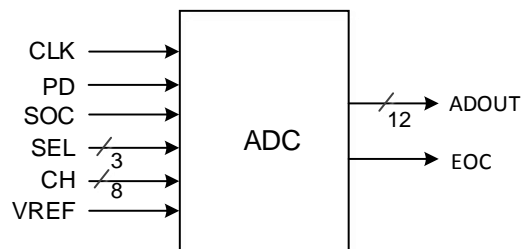

端口介绍

表 7-9 ADC 端口介绍

端口	I/O	描述
ADOUT[11:0]	Output	ad conversion results.
EOC	Output	end of conversion.
CLK	Input	main clock.
PD	Input	power down signal.
SOC	Input	start of conversion.
SEL[2:0]	Input	channel select signal.

端口	I/O	描述
CH[7:0]	Input	channel signal-ended analog voltage input.
VREF	Input	voltage reference

原语例化

Verilog 例化:

```

ADC adc_inst(
    .CLK(clk),
    .PD(pd),
    .SOC(soc),
    .SEL(sel[2:0]),
    .CH(ch[7:0]),
    .VREF(vref),
    .EOC(eoc),
    .ADOUT(adout[11:0])
);

```

Vhdl 例化:

```

COMPONENT ADC
    PORT(
        CLK=>IN std_logic;
        PD=>IN std_logic;
        SOC=>IN std_logic;
        SEL=>IN std_logic_vector(2 downto 0);
        CH=>IN std_logic_vector(7 downto 0);
        VREF=>IN std_logic;
        EOC=>OUT std_logic;
        ADOUT=>OUT std_logic_vector(11 downto 0)
    );
END COMPONENT;
uut=> ADC
    PORT MAP (
        CLK=>clk,
        PD=>pd,
        SOC=>soc,
        SEL=>sel,
        CH=>ch,
        VREF=>vref,

```

```

EOC=>eoc,
ADOUT=>adout
);

```

IP 调用

在 IP Core Generator 界面中单击“ADC”，界面右侧会显示 ADC 的相关信息概要。

IP 配置

在 IP Core Generator 界面中，双击“ADC”，弹出 ADC 的“IP Customization”窗口，该窗口包括“File”配置框、“Options”配置框以及端口显示框图，如图 7-5 所示。

图 7-5 ADC 的 IP Customization 窗口结构

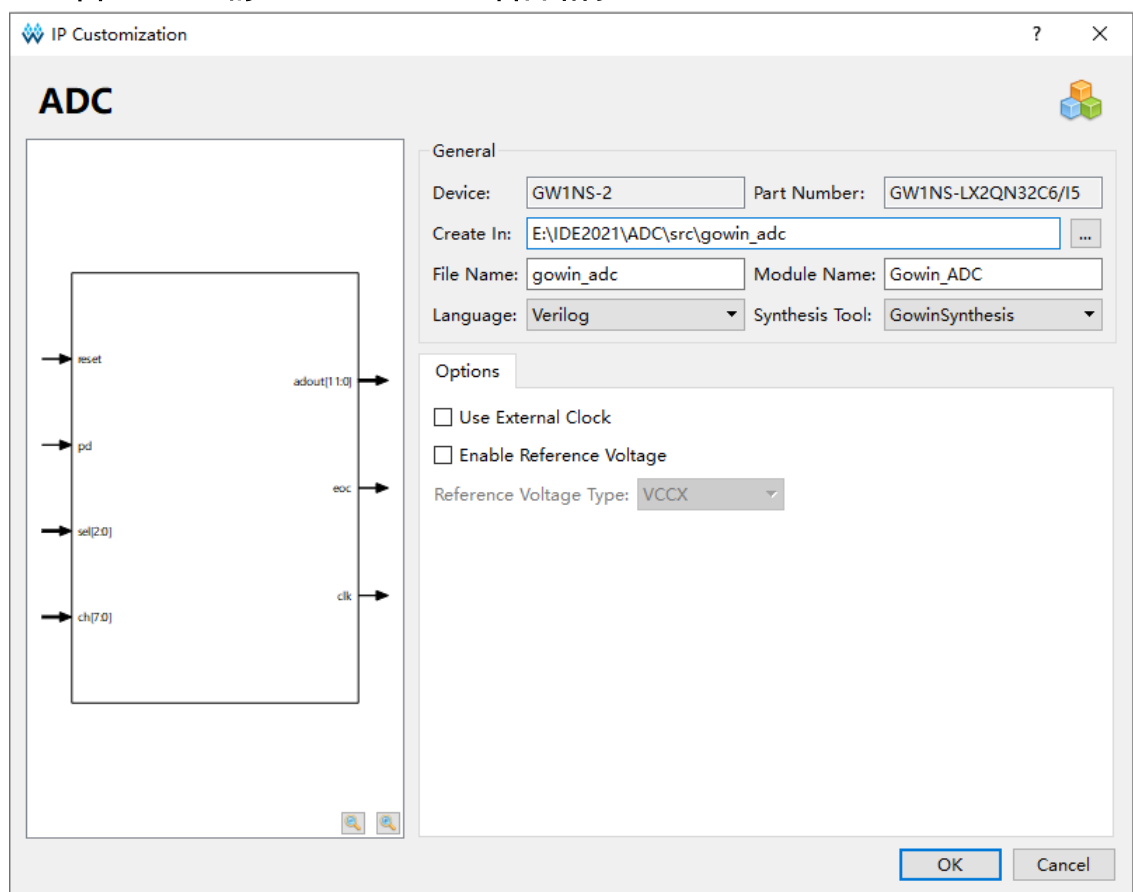

1. File 配置框

File 配置框用于配置产生的 IP 设计文件的相关信息。

- **Device:** 显示已配置的 Device 信息；
- **Part Number:** 显示已配置的 Part Number 信息；
- **Create In:** 配置产生的 IP 设计文件的目标路径。可在右侧文本框中重新编辑目标路径，也可通过文本框右侧选择按钮选择目标路径。

- **File Name:** 配置产生的 IP 设计文件的文件名。在右侧文本框可重新编辑文件名称；
- **Module Name:** 配置产生的 IP 设计文件的 module name。在右侧文本框可重新编辑模块名称。Module Name 不能与原语名称相同，若相同，则报出 Error 提示；
- **Language:** 配置产生的 IP 设计文件的硬件描述语言。选择右侧下拉列表框，选择目标语言，支持 Verilog 和 VHDL；
- **Synthesis Tool:** 配置要使用的综合工具。选择右侧下拉列表框，选择目标工具，支持 GowinSynthesis[®]；

2. Options 配置框

Options 配置框用于用户自定义配置 IP，Options 配置框如图 7-5 所示。

- **Use External Clock:** 配置 ADC 是否使用外部时钟；
- **Enable Reference Voltage:** 配置 ADC 是否使能参考电压。若使能，则通过选项 Reference Voltage Type 选择参考电压类型；若不使能，则默认参考电压为 VCCX。
- **Reference Voltage Type:** 配置参考电压的类型，包括 VCCX、34/40(*VCCX)、31/40(*VCCX)、29/40(*VCCX)、27/40(*VCCX)、22/40(*VCCX)、20/40(*VCCX)和 External。

3. 端口显示框图

端口显示框图显示 IP Core 的配置结果示例框图，如图 7-5 所示。

IP 生成文件

IP 窗口配置完成后，产生以配置文件“File Name”命名的三个文件，以默认配置为例进行介绍：

- IP 设计文件“gowin_adc.v”为完整的 verilog 模块，根据用户的 IP 配置，产生对应功能的 ADC 模块。
- IP 设计使用模板文件 gowin_adc_tmp.v，为用户提供 IP 设计使用模板文件；
- IP 配置文件“gowin_adc.ipc”，用户可加载该文件对 IP 进行配置。

注！

如配置中选择语言是 VHDL，则产生的前两个文件名后缀为.vhd。

8 其它

8.1 GSR

原语介绍

GSR(Global Set/Reset)，全局置位/复位模块，可以实现全局置位/复位功能，低电平有效。默认一般连接高电平，若想动态控制，可连接外部信号，拉低实现寄存器等模块的复位。

端口示意图

图 8-1 GSR 端口示意图

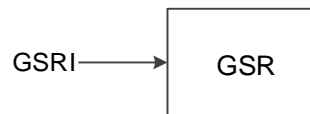

端口介绍

表 8-1 GSR 端口介绍

端口名	I/O	描述
GSRI	Input	GSR 输入，低电平有效

原语例化

Verilog 例化:

```

GSR gsr_inst(
    .GSRI(GSRI)
);
  
```

Vhdl 例化:

```

COMPONENT GSR
  PORT (
    GSRI:IN std_logic
  );
  
```

```

END COMPONENT;
gsr_inst:GSR
    PORT MAP(
        GSRI => GSRI
    );

```

8.2 INV

原语介绍

INV(Inverter)，取反模块。

端口示意图

图 8-2 INV 端口示意图



端口介绍

表 8-2 INV 端口介绍

端口名	I/O	描述
I	Input	INV 数据输入
O	Output	INV 数据输出

原语例化

Verilog 例化:

```

INV uut (
    .O(O),
    .I(I)
);

```

Vhdl 例化:

```

COMPONENT INV
    PORT (
        O:OUT std_logic;
        I:IN std_logic
    );
END COMPONENT;
uut:INV
    PORT MAP(
        O => O,

```

```

    | => |
);

```

8.3 VCC

原语介绍

逻辑高电平发生器。

端口示意图

图 8-3 VCC 端口示意图



端口介绍

表 8-3 VCC 端口介绍

端口名	I/O	描述
V	Output	VCC 输出

原语例化

Verilog 例化:

```

VCC uut (
    .V(V)
);

```

Vhdl 例化:

```

COMPONENT VCC
    PORT (
        V:OUT std_logic
    );
END COMPONENT;
uut:VCC
    PORT MAP(
        V => V
    );

```

8.4 GND

原语介绍

逻辑低电平发生器。

端口示意图

图 8-4 GND 端口示意图

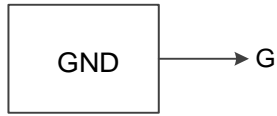

端口介绍

表 8-4 GND 端口介绍

端口名	I/O	描述
G	Output	GND 输出

原语例化

Verilog 例化:

```
GND uut (
    .G(G)
);
```

Vhdl 例化:

```
COMPONENT GND
    PORT (
        G:OUT std_logic
    );
END COMPONENT;
 uut:GND
    PORT MAP(
        G => G
```

```
);
```

8.5 BANDGAP

原语介绍

BANDGAP 的功能是为芯片中的某些模块提供恒定的电压和电流，若关掉 BANDGAP，则 OSC、PLL、FLASH 等模块将不再工作，可以起到降低器件功耗的作用。

适用器件

表 8-5 BANDGAP 适用器件

家族	系列	器件
小蜜蜂®	GW1NZ	GW1NZ-1, GW1NZ-1C
	GW1N	GW1N-2, GW1N-2B, GW1N-1P5, GW1N-1P5B
	GW1NR	GW1NR-2, GW1NR-2B

端口示意图

图 8-5 BANDGAP 端口示意图

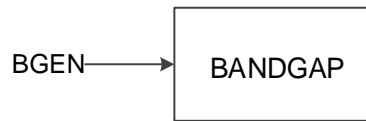

端口介绍

表 8-6 BANDGAP 端口介绍

端口名	I/O	描述
BGEN	Input	BANDGAP 使能信号，高电平有效。

原语例化

Verilog 例化:

```

    BANDGAP uut (
        .BGEN(bgen)
    );
  
```

Vhdl 例化:

```

    COMPONENT BANDGAP
      PORT (
        BGEN:IN std_logic
      );
    END COMPONENT;
    uut:BANDGAP
      PORT MAP(
        BGEN=> I
      );
  
```

IP 调用

在 IP Core Generator 界面中，单击“BandGap”，界面右侧会显示 BandGap 的相关信息概要。

IP 配置

在 IP Core Generator 界面中，双击 BandGap，弹出 BandGap 的“IP Customization”窗口。该窗口包括“File”配置框、“Options”配置框以及端口显示框图，如图 8-6 所示。

图 8-6 BandGap 的 IP Customization 窗口结构

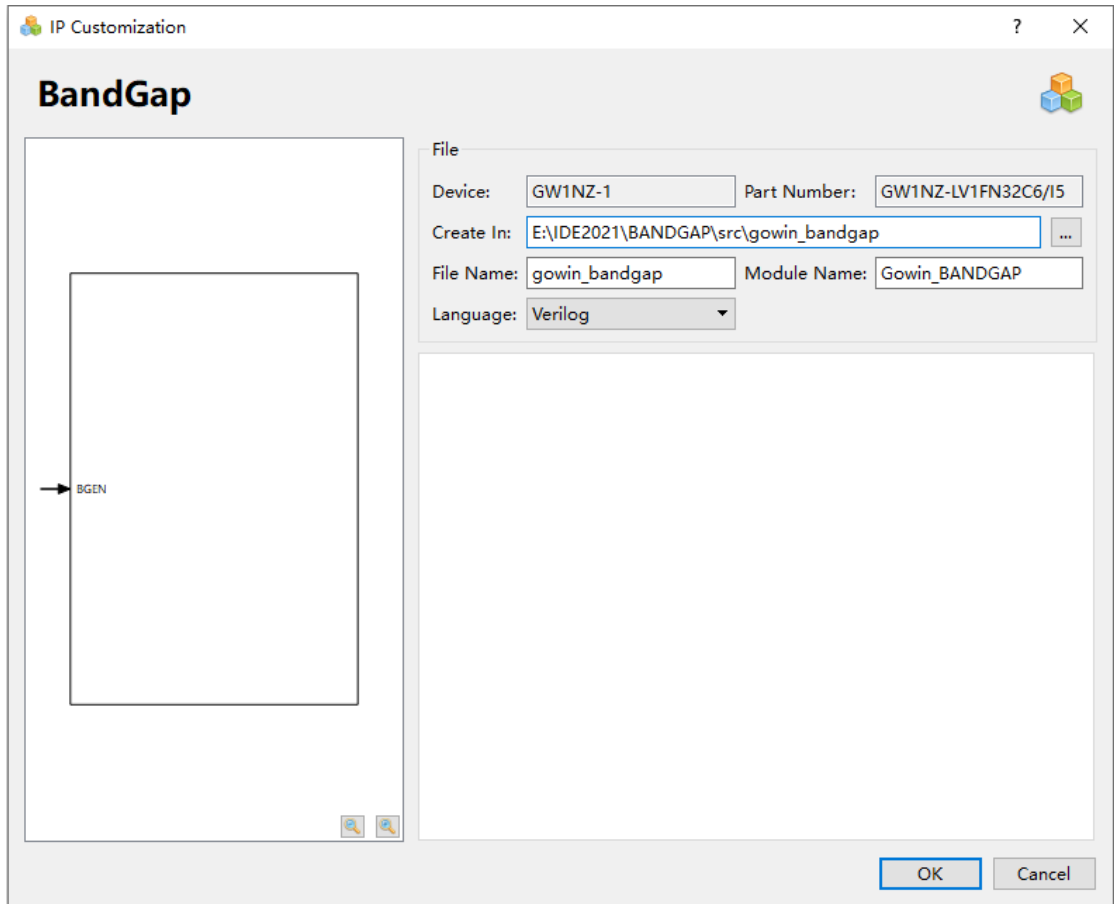

1. File 配置框

- File 配置框用于配置产生的 IP 设计文件的相关信息。
- BandGap 的 File 配置框的使用和 ADC 模块类似，具体请参考 7.4 ADC > IP 调用部分的 File 配置框。

2. 端口显示框图

端口显示框图显示当前 IP Core 的配置结果示例框图，如图 8-6 所示。

IP 生成文件

IP 窗口配置完成后，产生以配置文件“File Name”命名的三个文件，以默认配置为例进行介绍：

- IP 设计文件“gowin_bandgap.v”为完整的 verilog 模块，根据用户的 IP 配置，产生实例化的 BandGap；
- IP 设计使用模板文件 gowin_bandgap_tmp.v，为用户提供 IP 设计使用模板文件；
- IP 配置文件：“gowin_bandgap.ipc”，用户可加载该文件对 IP 进行配置。

注！

如配置中选择语言是 VHDL，则产生的前两个文件名后缀为.vhd。

8.6 SPMI

原语介绍

SPMI (System Power Management Interface) 是一种双线串行接口，可用于动态控制片上系统内部电源的关断与开启。

适用器件

表 8-7 SPMI 适用器件

家族	系列	器件
小蜜蜂®	GW1NZ	GW1NZ-1, GW1NZ-1C

端口示意图

图 8-7 SPMI 端口示意图

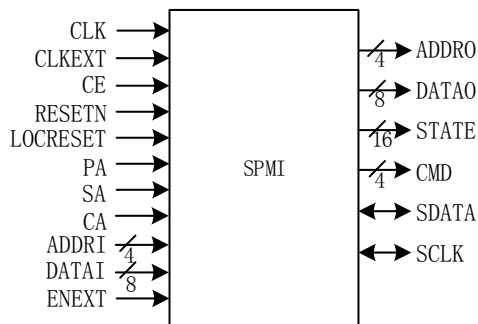

端口介绍

表 8-8 SPMI 端口介绍

端口	I/O	描述
CLK	input	Clock input
CLKEXT	input	External clock input
CE	input	Clock Enable
RESETN	input	Reset input
ENEXT	input	Enext input
LOCRESET	input	Local reset input
PA	input	Priority arbitration input
SA	input	Secondary arbitration input
CA	input	Connection arbitration input
ADDR1	input	Addr input
DATAI	input	Data input
ADDR0	output	Addr output
DATAO	output	datat output
STATE	output	state output
CMD	output	command output

端口	I/O	描述
SDATA	inout	SPMI Serial data
SCLK	inout	SPMI Serial Clock

原语例化

Verilog 例化:

```

SPMI uut (
    .ADDRO(addr0),
    .DATAO(datao),
    .STATE(state),
    .CMD(cmd),
    .SDATA(sdata),
    .SCLK(sclk),
    .CLK(clk),
    .CE(ce),
    .RESETN(resetn),
    .LOCRESET(locreset),
    .PA(pa),
    .SA(sa),
    .CA(ca),
    .ADDRI(addri),
    .DATAI(datai),
    .CLKEXT(clkext),
    .ENEXT(enext)
);

```

Vhdl 例化:

```

COMPONENT SPMI
  PORT(
    CLK:IN std_logic;
    CLKEXT:IN std_logic;
    CE:IN std_logic;
    RESETN:IN std_logic;
    ENEXT:IN std_logic;
    LOCRESET:IN std_logic;
    PA:IN std_logic;
    SA:IN std_logic;
    CA:IN std_logic;

```

```

        ADDR1:IN std_logic_vector(3 downto 0);
        DATA1:IN std_logic_vector(7 downto 0);
        ADDR0:OUT std_logic_vector(3 downto 0);
        DATA0:OUT std_logic_vector(7 downto 0);
        STATE:OUT std_logic_vector(15 downto 0);
        CMD:OUT std_logic_vector(3 downto 0);
        SDATA:INOUT std_logic;
        SCLK:INOUT std_logic
    );
END COMPONENT;
 uut: SPMI
    PORT MAP (
        CLK=>clk,
        CLKEXT=>clkext,
        CE=>ce,
        RESETN=>resetn,
        ENEXT=>enext,
        LOCRESET=>locreset,
        PA=>pa,
        SA=>sa,
        CA=>ca,
        ADDR1=>addr1,
        DATA1=>data1,
        ADDR0=>addr0,
        DATA0=>data0,
        STATE=>state,
        CMD=>cmd,
        SDATA=>sdata,
        SCLK=>sclk
    );

```

IP 调用

在 IP Core Generator 界面中，单击“SPMI”，界面右侧会显示 SPMI 的相关信息概要。

IP 配置

在 IP Core Generator 界面中，双击 SPMI，弹出 SPMI 的“IP Customization”窗口。该窗口包括“File”配置框、“Options”配置框以及端口显示框图，如图 8-8 所示。

图 8-8 SPMI 的 IP Customization 窗口结构

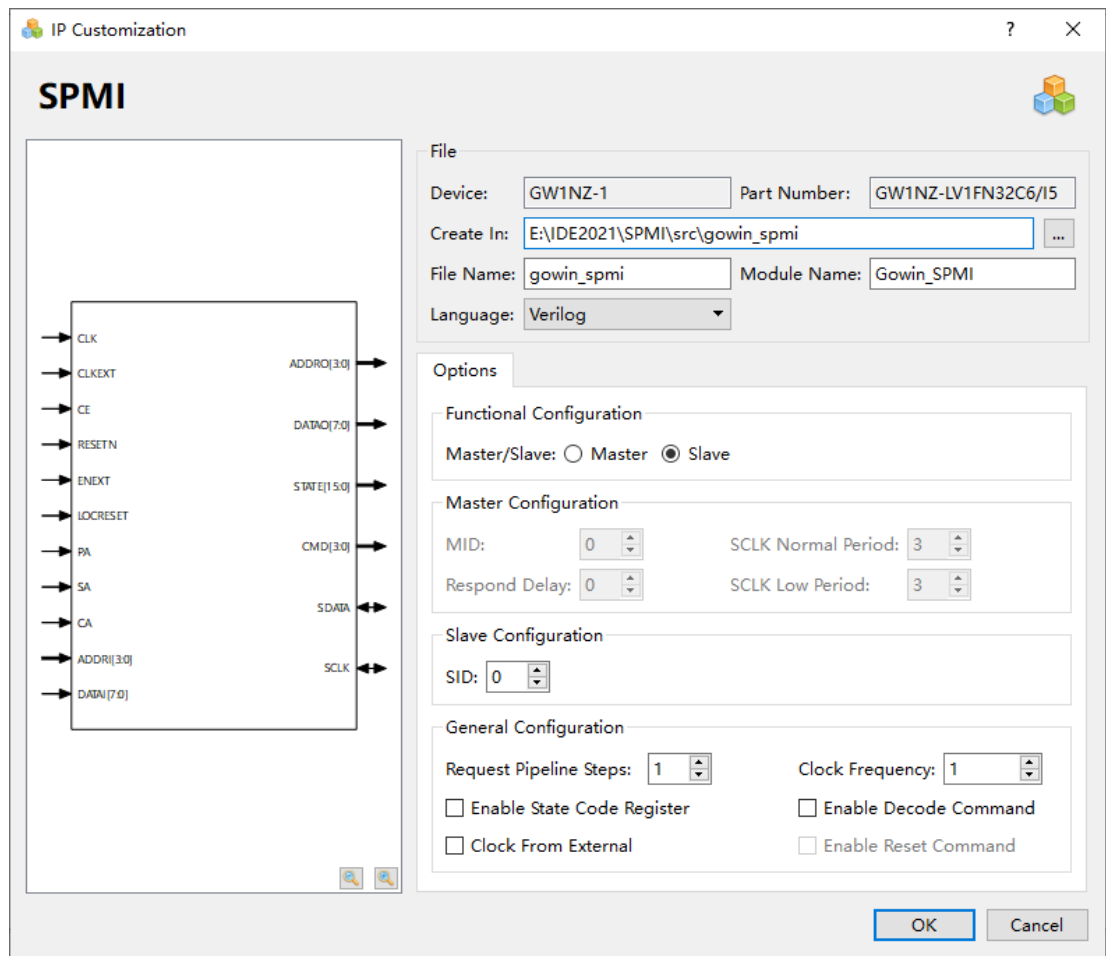

1. File 配置框

- File 配置框用于配置产生的 IP 设计文件的相关信息。
- SPMI 的 File 配置框的使用和 ADC 模块类似,具体请参考 7.4 ADC > IP 调用部分的 File 配置框。

2. Options 配置框

- Options 配置框用于用户自定义配置 IP, Options 配置框如图 8-8 所示。
- Functional Configuration:
 - Shutdown by VCCEN: 通过外部引脚 VCCEN 关闭。如果选择此选项,则 SPMI 的通信功能将不可用。
 - Master/Slave: 将 SPMI 设置为主机或从机。
- Master Configuration:
 - MID: 主机的 ID, 设置范围为 0-3, 默认值为 0。
 - Respond Delay: 设置响应延迟时间。

- SCLK Normal Period: Normal 模式下 sclk 的周期长度。
- SCLK Low Period: 睡眠模式下 sclk 的周期长度。
- Slave Configuration:
 - SID: 设置 SPMI 从机的 ID。
- General configuration:
 - Enable State Code Register: 启用或禁用寄存器。例如, 如果选择“启用状态代码寄存器”选项, 则输出 STATE 数据将通过一个寄存器。
 - Request Pipeline Steps: 设置请求信号采样时间的延迟步长。
 - Enable Decode Command: 启用或禁用解码。如果选择启用解码命令, SPMI 将解码复位, 睡眠, 关闭和唤醒命令。
 - Enable Reset Command: 启用或禁用重置命令。
 - Clock From External: 启用或禁用外部时钟。
 - Clock Frequency: 系统时钟频率。

3. 端口显示框

端口显示框图显示当前 IP Core 的配置结果示例框图, 如图 8-8 所示。

IP 生成文件

IP 窗口配置完成后, 产生以配置文件“File Name”命名的三个文件, 以默认配置为例进行介绍:

- IP 设计文件“gowin_spmi.v”为完整的 verilog 模块, 根据用户的 IP 配置, 产生实例化的 SPMI;
- IP 设计使用模板文件 gowin_spmi_tmp.v, 为用户提供 IP 设计使用模板文件;
- IP 配置文件: “gowin_spmi.ipc”, 用户可加载该文件对 IP 进行配置。

注!

如配置中选择的语言是 VHDL, 则产生的前两个文件名后缀为.vhd。

8.7 I3C

原语介绍

I3C (Improved Inter Integrated Circuit)是一种两线式总线，兼具了 I2C 和 SPI 的关键特性，能有效的减少集成电路芯片系统的物理端口、支持低功耗、高数据速率和其他已有端口协议的优点。

适用器件

表 8-9 I3C 适用器件

家族	系列	器件
小蜜蜂®	GW1NZ	GW1NZ-1, GW1NZ-1C

端口示意图

图 8-9 I3C 端口示意图

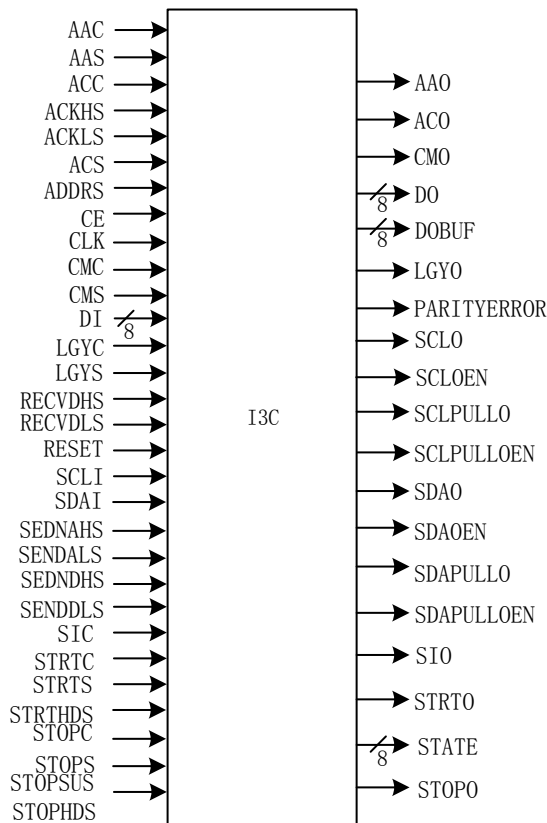

端口介绍

表 8-10 I3C 端口介绍

端口	I/O	描述
CE	input	Clock Enable
RESET	input	Reset input
CLK	input	Clock input

端口	I/O	描述
LGYS	input	The current communication object is the I2C setting signal
CMS	input	The device enters the Master's set signal
ACS	input	Select the setting signal when determining whether to continue.
AAS	input	Reply the ACK setting signal when a reply is required from the ACK/NACK
STOPS	input	Input the STOP command
STRTS	input	Input the START command.
LYGC	input	The current communication object is the I2C
CMC	input	The reset signal that the device is in master.
ACC	input	The reset signal that selects continue when selecting whether to continue
AAC	input	Reply the ACK reset signal when a reply is required from the ACK/NACK
SIC	input	Interrupt to identify the reset signal
STOPC	input	The reset signal is in STOP state
STRTC	input	The reset signal is in START state
STRTHDS	input	Adjust the setting signal when generating START
SENDAHS	input	Adjust the setting signal of SCL at a high level when the address is sent.
SENDALS	input	Adjust the setting signal of SCL at a low level when the address is sent
ACKHS	input	Adjust the setting signal of SCL at a high level in ACK.
SENDLDS	input	Adjust the setting signal of SCL at a low level in ACK.
RECVHDS	input	Adjust the setting signal of SCL at a high level when the data are received
RECVLDS	input	Adjust the setting signal of SCL at a low level when the data are received
ADDRS	input	The slave address setting interface
DI	input	Data Input.
SDAI	input	I3C serial data input
SCLI	input	I3C serial clock input
LGYO	output	Output the current communication object as the I2C command.
CMO	output	Output the command of the device is in the Master mode.
ACO	output	Continue to output when selecting whether to continue
AAO	output	Reply ACK when you need to reply ACK/NACK
SIO	output	Interrupt to output the identity bit
STOPO	output	Output the STOP command
STRTO	output	Output the START command
PARITYERROR	output	Output check when receiving data
DOBUF	output	Data output after caching

端口	I/O	描述
DO	output	Data output directly
STATE	output	Output the internal state
SDAO	output	I3C serial data output
SCLO	output	I3C serial clock output
SDAOEN	output	I3C serial data oen output
SCLOEN	output	I3C serial clock oen output
SDAPULLO	output	Controllable pull-up of the I3C serial data
SCLPULLO	output	Controllable pull-up of the I3C serial clock
SDAPULLOEN	output	Controllable pull-up of the I3C serial data oen
SCLPULLOEN	output	Controllable pull-up of the I3C serial clock oen

原语例化

Verilog 例化:

```

I3C i3c_inst (
    .LGYO(lgyo),
    .CMO(cmo),
    .ACO(aco),
    .AAO(aao),
    .SIO(sio),
    .STOPO(stopo),
    .STRTO(strto),
    .PARITYERROR(parityerror),
    .DOBUF(dobuf),
    .DO(dout),
    .STATE(state),
    .SDAO(sdao),
    .SCLO(sclo),
    .SDAOEN(sdaoen),
    .SCLOEN(scloen),
    .SDAPULLO(sdapullo),
    .SCLPULLO(sclpullo),
    .SDAPULLOEN(sdapulloen),
    .SCLPULLOEN(sclpulloen),
    .LGYS(lgys),
    .CMS(cms),
    .ACS(acs),
    .AAS(aas),

```

```

.STOPS(stops),
.STRTS(strts),
.LGYC(lgyc),
.CMC(cmc),
.ACC(acc),
.AAC(aac),
.SIC(sic),
.STOPC(stopc),
.STRTC(strtc),
.STRTHDS(strthds),
.SENDAHS(sendahs),
.SENDALS(sendals),
.ACKHS(ackhs),
.ACKLS(ackls),
.STOPSUS(stopsus),
.STOPHDS(stophds),
.SENDDHS(senddhs),
.SENDDLs(senddls),
.RECVDHS(recvdhs),
.RECVDLs(recvdls),
.ADDRS(addr),
.DI(di),
.SDAI(sdai),
.SCLI(scli),
.CE(ce),
.RESET(reset),
.CLK(clk)
);

```

Vhdl 例化:

```

COMPONENT I3C
  PORT (
    LGYO: OUT STD_LOGIC;
    CMO: OUT STD_LOGIC;
    ACO: OUT STD_LOGIC;
    AAO: OUT STD_LOGIC;
    SIO: OUT STD_LOGIC;
    STOPO: OUT STD_LOGIC;
    STRTO: OUT STD_LOGIC;

```

```
PARITYERROR: OUT STD_LOGIC;
DOBUF: OUT STD_LOGIC_VECTOR(7 DOWNT0 0);
DOUT: OUT STD_LOGIC_VECTOR(7 DOWNT0 0);
STATE: OUT STD_LOGIC_VECTOR(7 DOWNT0 0);
SDAO: OUT STD_LOGIC;
SCLO: OUT STD_LOGIC;
SDAOEN: OUT STD_LOGIC;
SCLOEN: OUT STD_LOGIC;
SDAPULLO: OUT STD_LOGIC;
SCLPULLO: OUT STD_LOGIC;
SDAPULLOEN: OUT STD_LOGIC;
SCLPULLOEN: OUT STD_LOGIC;
LGYS: IN STD_LOGIC;
CMS: IN STD_LOGIC;
ACS: IN STD_LOGIC;
AAS: IN STD_LOGIC;
STOPS: IN STD_LOGIC;
STRTS: IN STD_LOGIC;
LGYC: IN STD_LOGIC;
CMC: IN STD_LOGIC;
ACC: IN STD_LOGIC;
AAC: IN STD_LOGIC;
SIC: IN STD_LOGIC;
STOPC: IN STD_LOGIC;
STRTC: IN STD_LOGIC;
STRTHDS: IN STD_LOGIC;
SENDAHS: IN STD_LOGIC;
SENDALS: IN STD_LOGIC;
ACKHS: IN STD_LOGIC;
ACKLS: IN STD_LOGIC;
STOPSUS: IN STD_LOGIC;
STOPHDS: IN STD_LOGIC;
SENDHDS: IN STD_LOGIC;
SENDDL: IN STD_LOGIC;
RECVHDS: IN STD_LOGIC;
RECVDL: IN STD_LOGIC;
ADDRS: IN STD_LOGIC;
DI: IN STD_LOGIC_VECTOR(7 DOWNT0 0);
```

```
        SDAI: IN STD_LOGIC;
        SCLI: IN STD_LOGIC;
        CE: IN STD_LOGIC;
        RESET: IN STD_LOGIC;
        CLK: IN STD_LOGIC
    );
END COMPONENT;

 uut: I3C
    PORT MAP (
        LGYO => lgyo,
        CMO => cmo,
        ACO => aco,
        AAO => aao,
        SIO => sio,
        STOPO => stopo,
        STRTO => strto,
        PARITYERROR => parityerror,
        DOBUF => dobuf,
        DOUT => dout,
        STATE => state,
        SDAO => sdao,
        SCLO => sclo,
        SDAOEN => sdaoen,
        SCLOEN => scloen,
        SDAPULLO => sdapullo,
        SCLPULLO => sclpullo,
        SDAPULLOEN => sdapulloen,
        SCLPULLOEN => sclpulloen,
        LGYS => lgys,
        CMS => cms,
        ACS => acs,
        AAS => aas,
        STOPS => stops,
        STRTS => strts,
        LGYC => lgyc,
        CMC => cmc,
        ACC => acc,
```

```
AAC => aac,  
SIC => sic,  
STOPC => stopc,  
STRTC => strtc,  
STRTHDS => strthds,  
SENDAHS => sendahs,  
SENDALS => sendals,  
ACKHS => ackhs,  
ACKLS => ackls,  
STOPSUS => stopsus,  
STOPHDS => stophds,  
SEND DHS => senddhs,  
SEND DLS => senddls,  
RECV DHS => recvdhs,  
RECV DLS => recvdls,  
ADDRS => addrs,  
DI => di,  
SDAI => sdai,  
SCLI => scli,  
CE => ce,  
RESET => reset,  
CLK => clk  
);
```

IP 调用

在 IP Core Generator 界面中单击 I3C 下的 I3C SDR，界面右侧会显示 I3C SDR 的相关信息概要。

IP 配置

在 IP Core Generator 界面中，双击“I3C SDR”，弹出 I3C 的“IP Customization”窗口，该窗口包括“File”配置框、“Options”配置框以及端口显示框图，如图 8-10 所示。

图 8-10 I3C 的 IP Customization 窗口结构

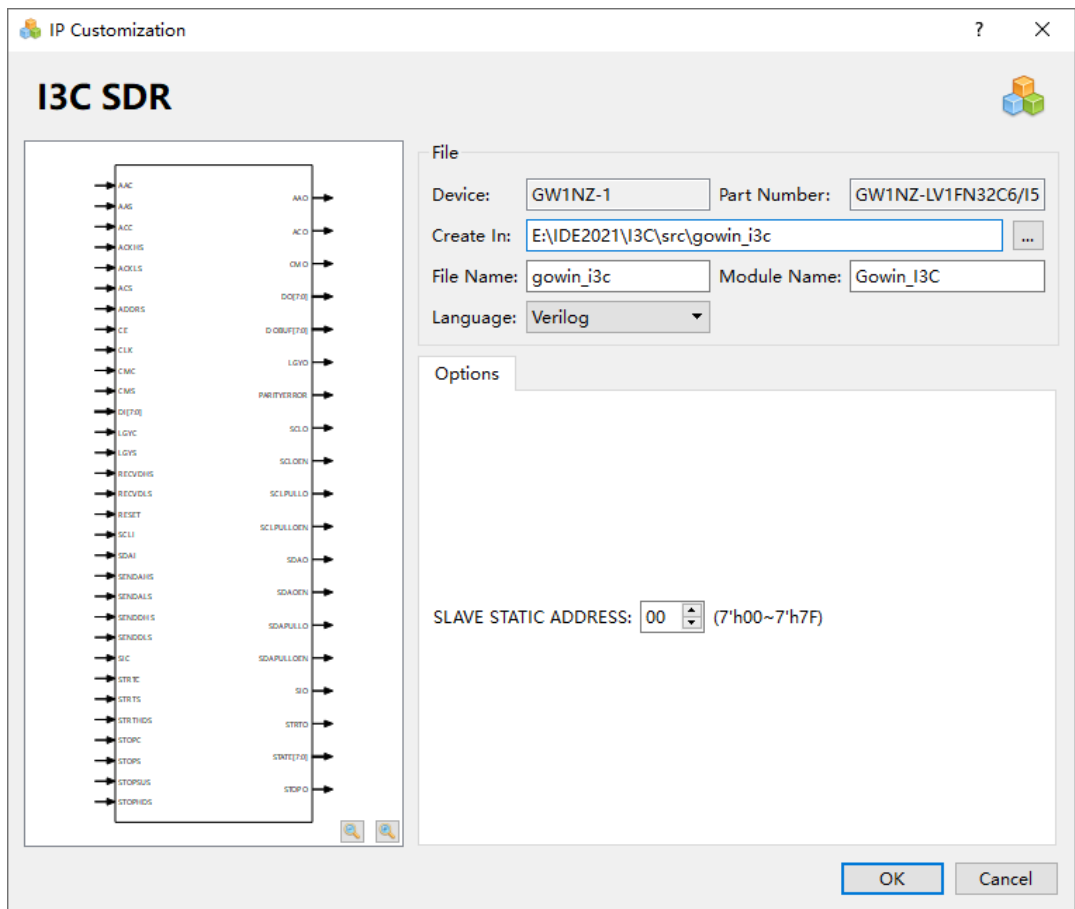

1. File 配置框

- File 配置框用于配置产生的 IP 设计文件的相关信息。
- I3C 的 File 配置框的使用和 ADC 模块的类似，请参考 7.4 ADC > IP 调用部分的 File 配置框。

2. Options 配置框

- Options 配置框用于用户自定义配置 IP，Options 配置框如图 8-10 所示。
- SLAVE STATIC ADDRESS - 指定从机的静态地址。

3. 端口显示框图

端口显示框图显示 IP Core 的配置结果示例框图，如图 8-10 所示。

IP 生成文件

IP 窗口配置完成后，产生以配置文件“File Name”命名的三个文件，以默认配置为例进行介绍：

- IP 设计文件“gowin_i3c.v”为完整的 verilog 模块，根据用户的 IP 配置，产生实例化的 I3C；

- IP 设计使用模板文件 `gowin_i3c_tmp.v`，为用户提供 IP 设计使用模板文件；
- IP 配置文件：“`gowin_i3c.ipc`”，用户可加载该文件对 IP 进行配置。

注！

如配置中选择的语言是 VHDL，则产生的前两个文件名后缀为 `.vhd`。

8.8 activeFlash

原语介绍

激活内嵌 SPI Nor flash 用作 user flash 的模块。实例化 `activeFlash` 时，`I_active_flash_sclk` 需为时钟信号，不能为常量；`I_active_flash_holdn` 可以为常量 `VCC` 或 `signal`，不能为常量 `GND`。

注！

实例化 `activeFlash`，用户设计资源会增加 14 个 LUT 和 10 个 REG 资源。

适用器件

表 8-11 activeFlash 适用器件

家族	系列	器件
晨熙 [®]	GW2AN	GW2AN-18X, GW2AN-9X, GW2AN-4X

端口示意图

图 8-11 activeFlash 端口示意图



端口介绍

表 8-12 activeFlash 端口介绍

端口	I/O	描述
<code>I_active_flash_holdn</code>	input	控制时钟保持信号，高电平输入激活 flash。
<code>I_active_flash_sclk</code>	input	时钟输入信号
<code>O_active_flash_ready</code>	output	Ready 输出标志，高电平表示 Flash 已被激活。

原语例化

Verilog 例化：

```

activeFlash activeFlash_inst (
    . I_active_flash_holdn I_active_flash_holdn),
    . I_active_flash_sclk (I_active_flash_sclk),
    . O_active_flash_ready (O_active_flash_ready)
  
```



```
);
```

Vhdl 例化:

```
COMPONENT activeFlash
  PORT(
    I_active_flash_holdn:IN std_logic;
    I_active_flash_sclk:IN std_logic;
    O_active_flash_ready:OUT std_logic
  );
END COMPONENT;
 uut: activeFlash
  PORT MAP (
    I_active_flash_holdn => I_active_flash_holdn,
    I_active_flash_sclk => I_active_flash_sclk,
    O_active_flash_ready => O_active_flash_ready
  );
```

调用条件

满足以下条件之一时，需要在用户设计中实例化 activeFlash 模块。

1. 云源软件 Configuration--Bitstream 配置页面 background programming 设置为 I2C/JTAG/SSPI/QSSPI，需要实例化 activeFlash;
2. 云源软件 Configuration--Bitstream 配置页面 background programming 设置为 OFF，且使用 SPI Nor Flash Interface IP 时，需要实例化 activeFlash。

