

SCHEMATIC	CONTENT	PAGE
PAGE1	COVER PAGE	1
PAGE2	SYSTEM DIAGRAM	2
PAGE3	POWER	3
PAGE4	POWER	4
PAGE5	POWER	5
PAGE6	FPGA-Config	6
PAGE7	FPGA-Power	7
PAGE8	DDR3	8
PAGE9	HDMI&USB to DownLoad	9
PAGE10	MIPI	10
PAGE11	SDI	11
PAGE12	Type-C	12

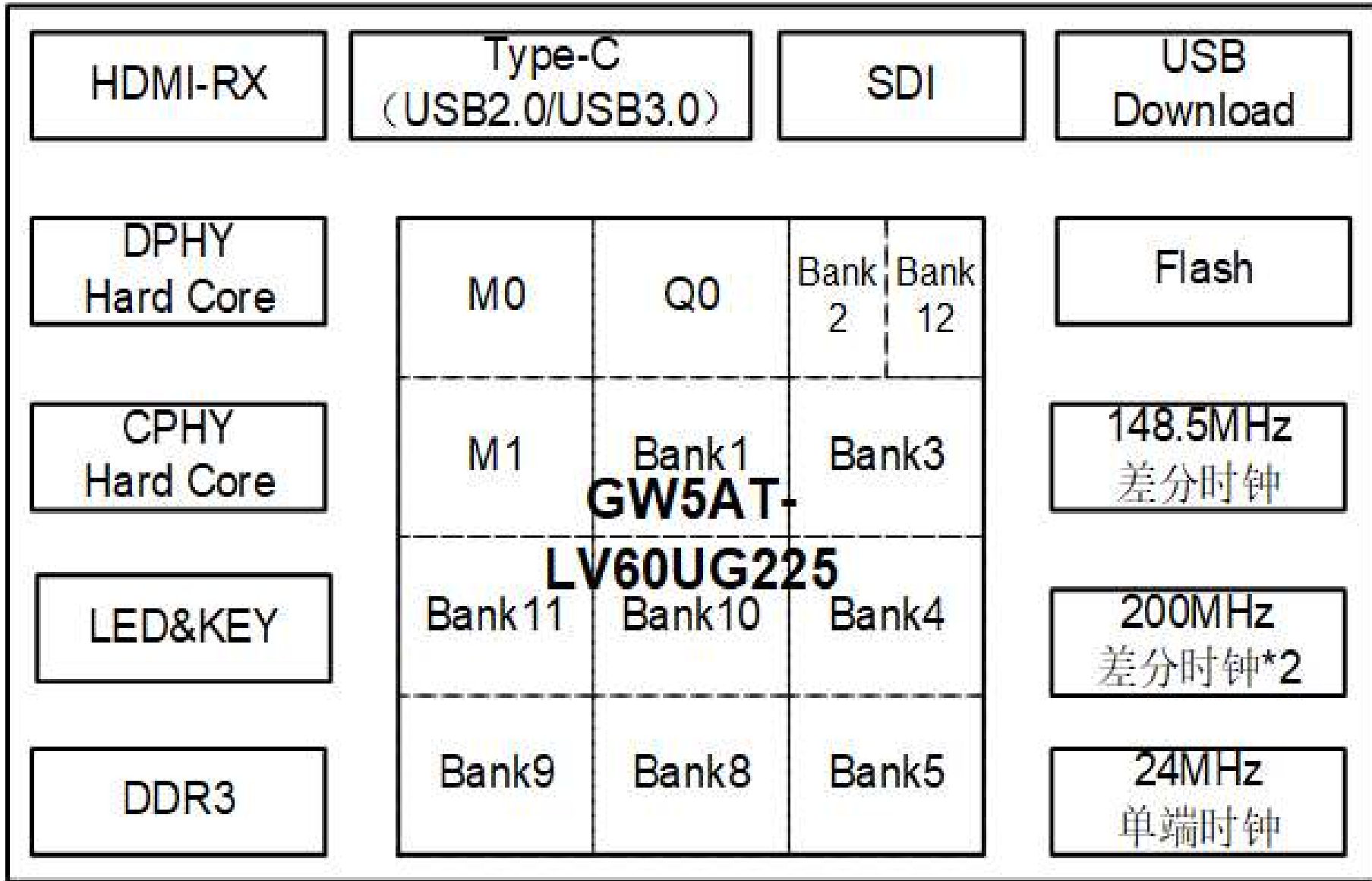

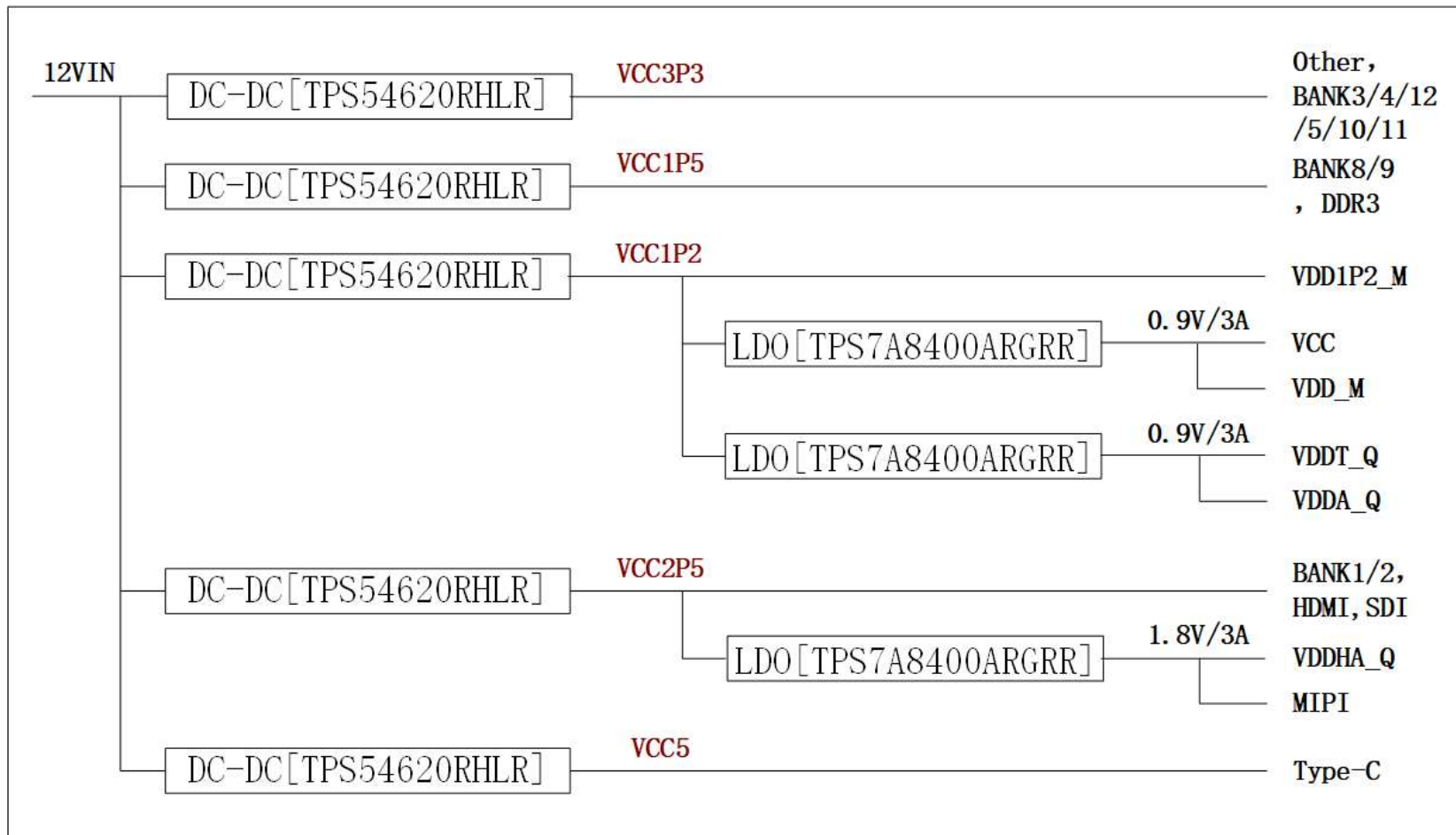

POWER

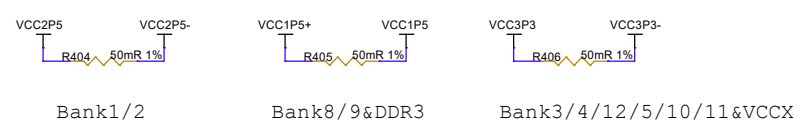
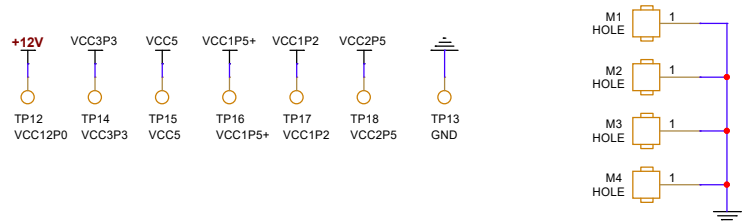
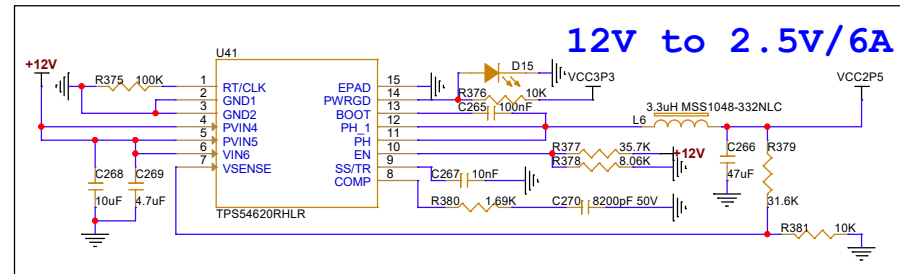
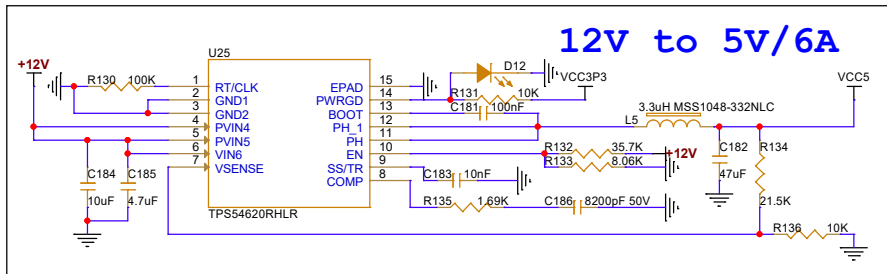
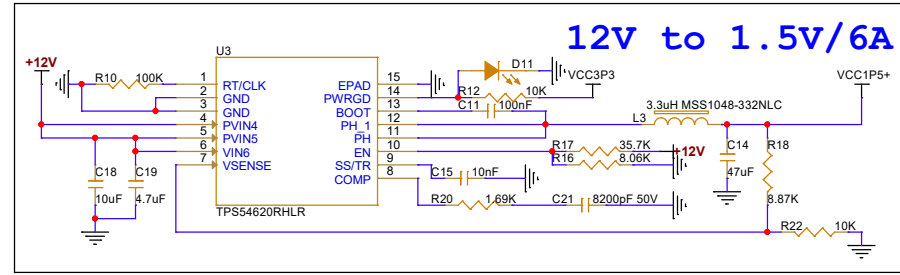
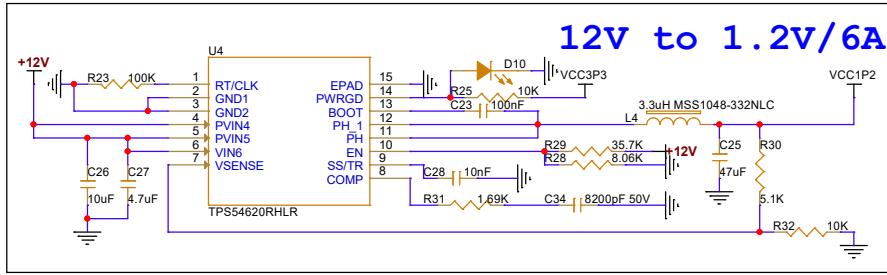
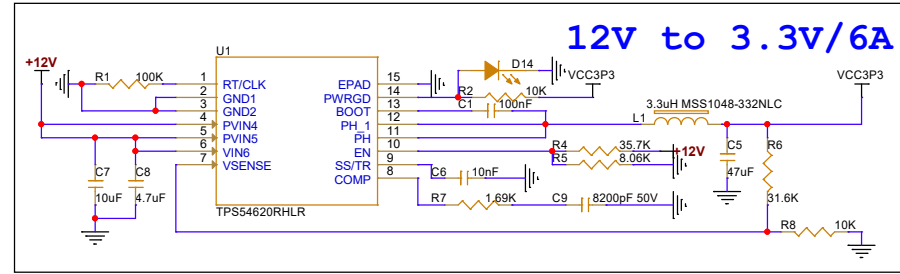
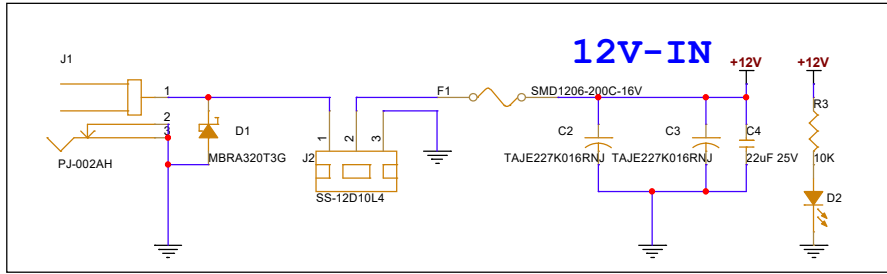

Title		
DK_USB_GW5AT-LV6UG225		
Size	Document Number	Rev
A3	POWER	1.0
Date:	Wednesday, December 11, 2024	Sheet 4 of 12

POWER

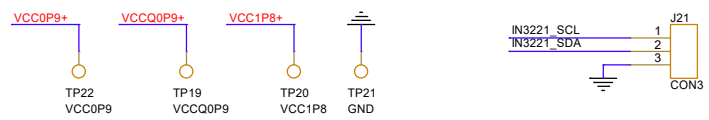
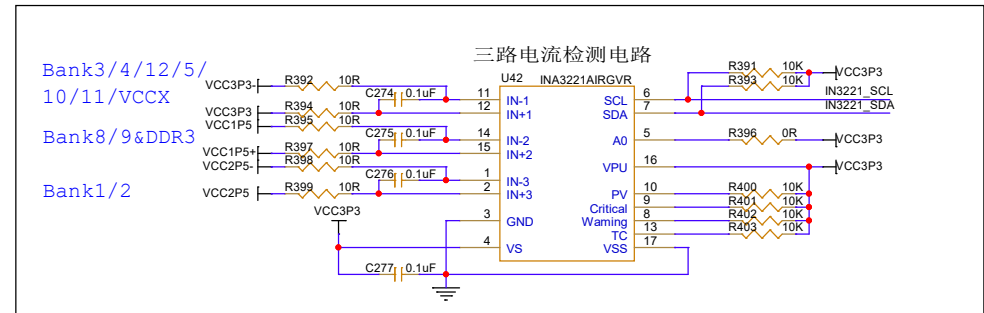
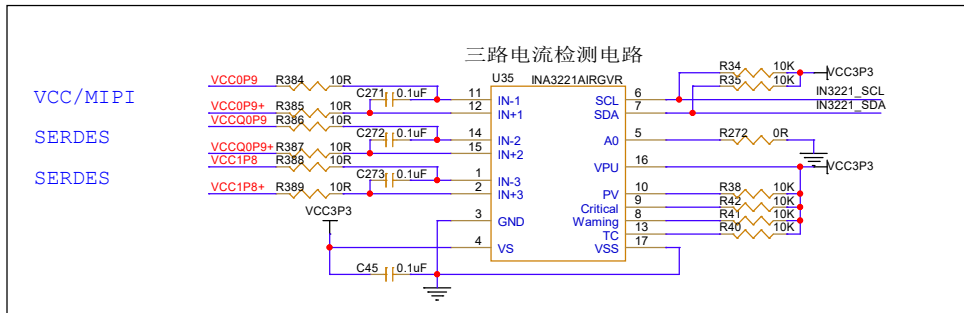
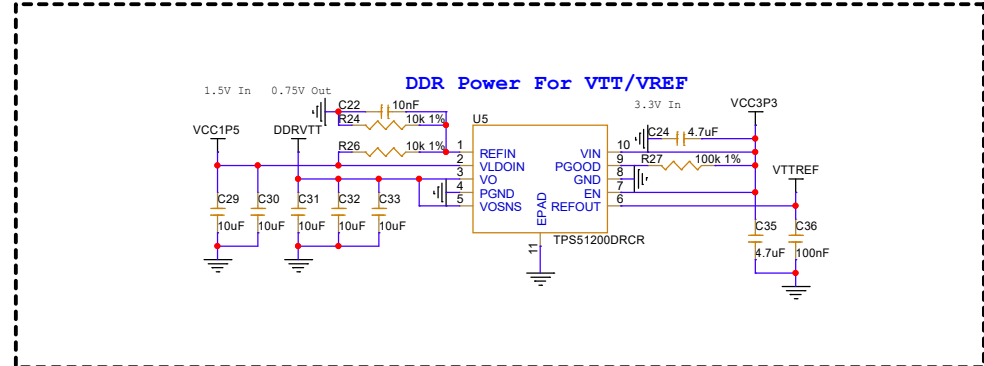
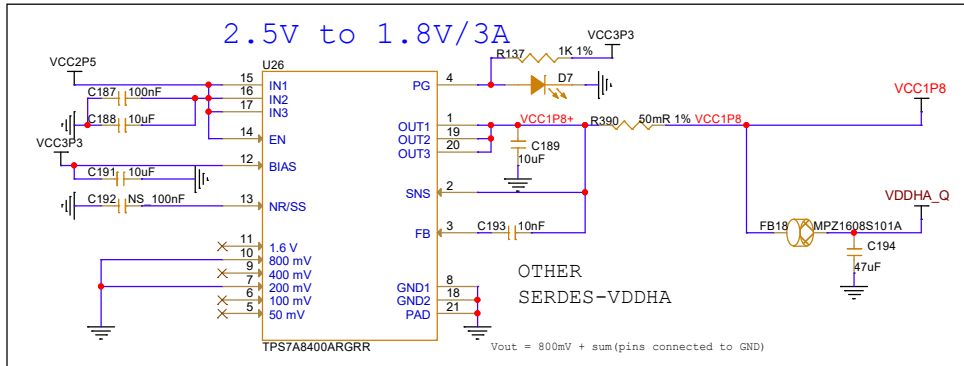
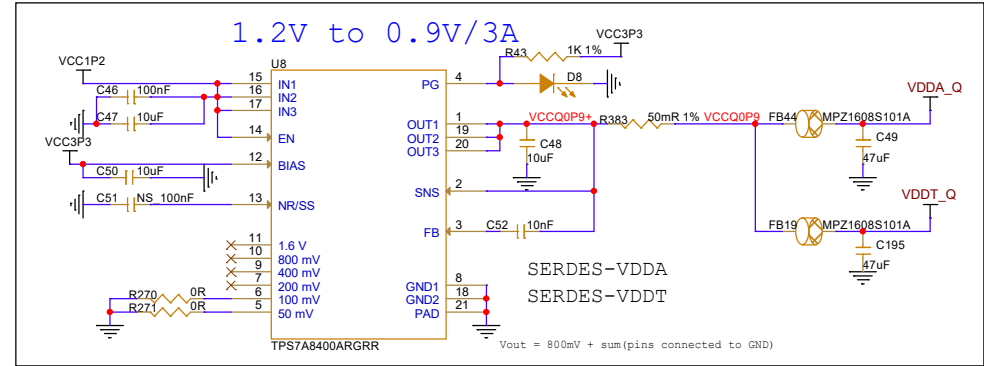
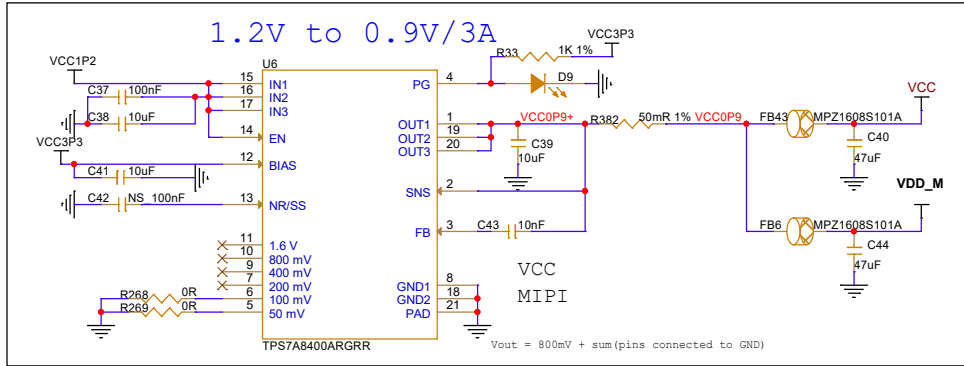

Title		DK_USB_GW5AT-LV60UG225
Size	Document Number	Rev
A3	POWER	1.0
Date:	Wednesday, December 11, 2024	Sheet 5 of 12

FPGA-Config

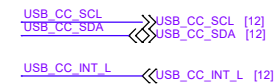
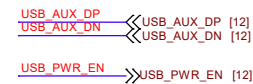
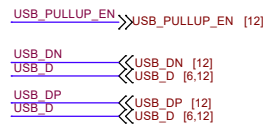
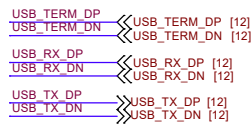
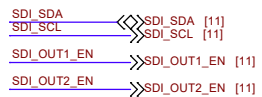
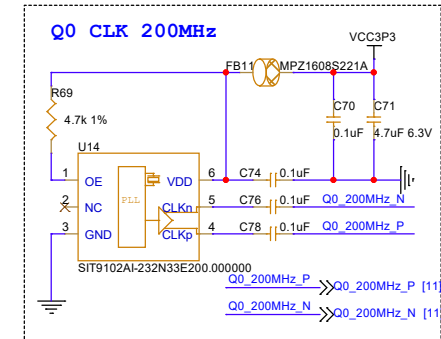
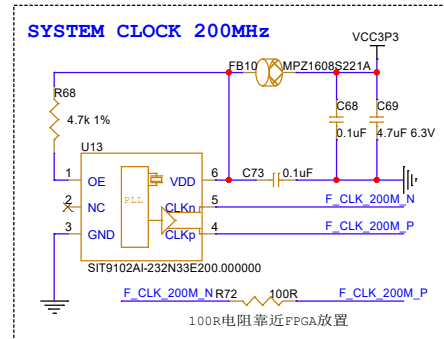
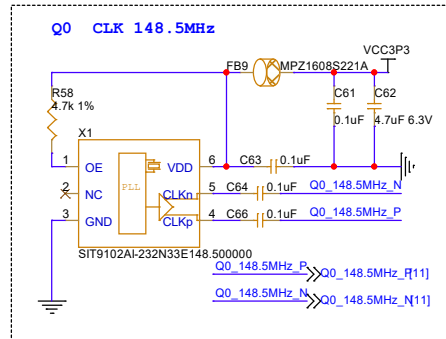
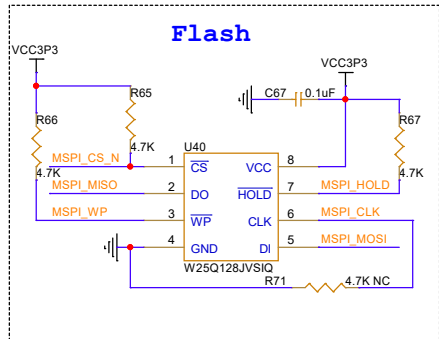
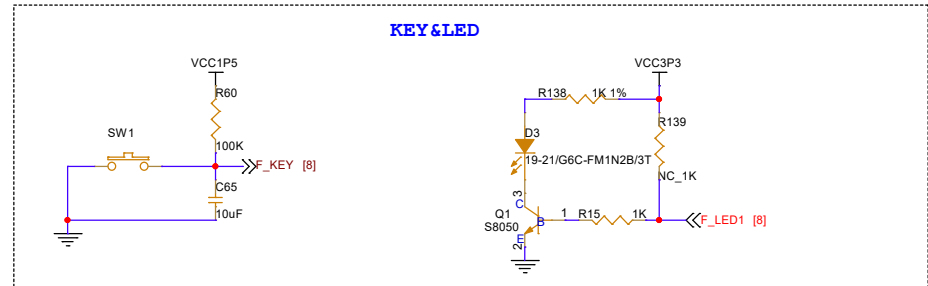
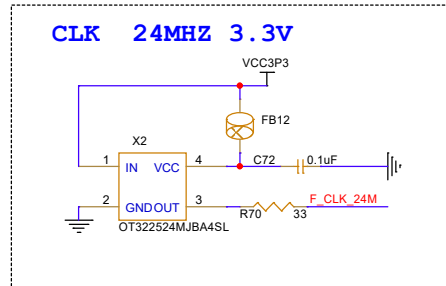
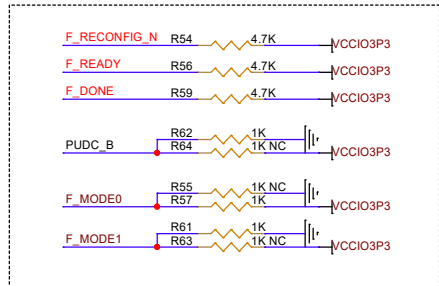
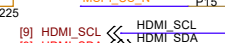
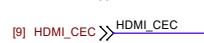
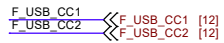
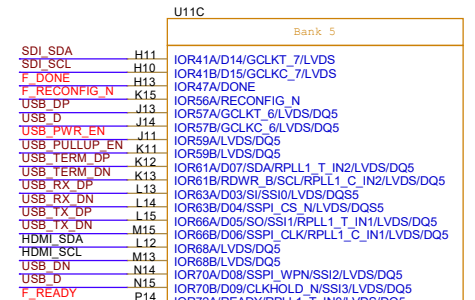
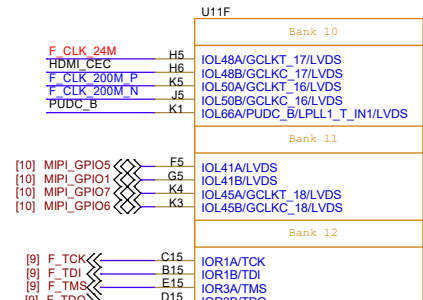
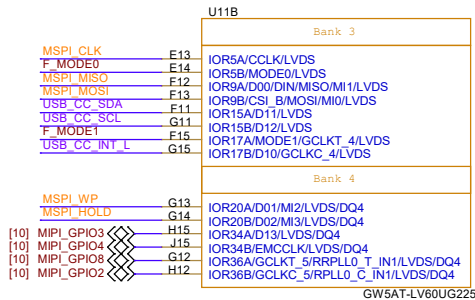
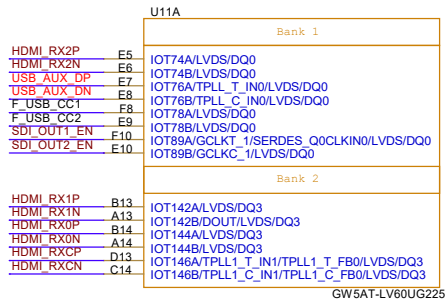

Title		
DK_USB_GW5AT-LV60UG225		
Size	Document Number	Rev
A3	FPGA-Config_Flash,CLK,KEY,LED	1.0
Date:	Monday, November 11, 2024	Sheet 6 of 12

FPGA-POWER

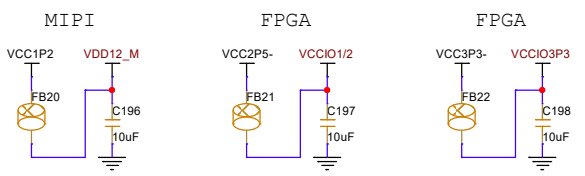
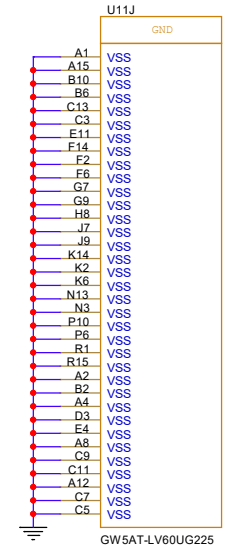
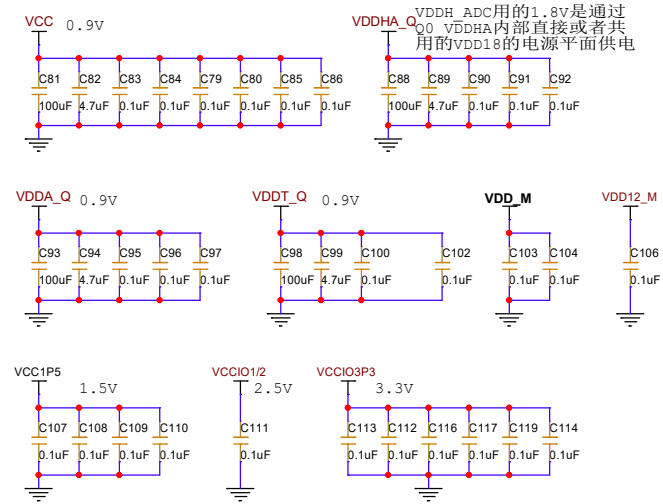
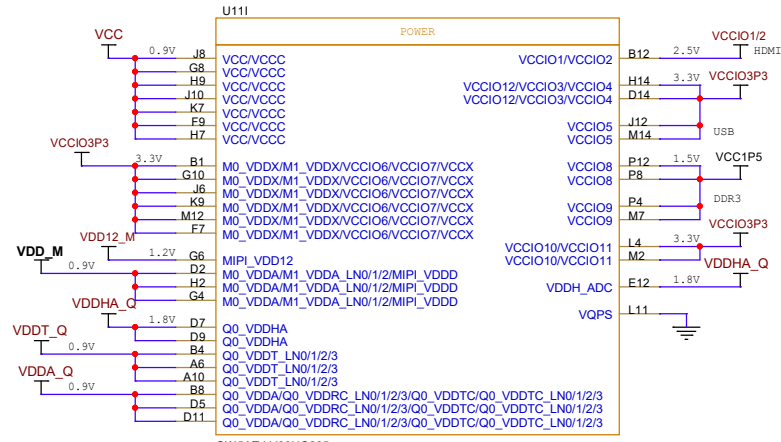

VDDH_ADC用的1.8v是通过Q0_VDDHA内部直接或者共用的VDD18的电源平面供电

DDR3

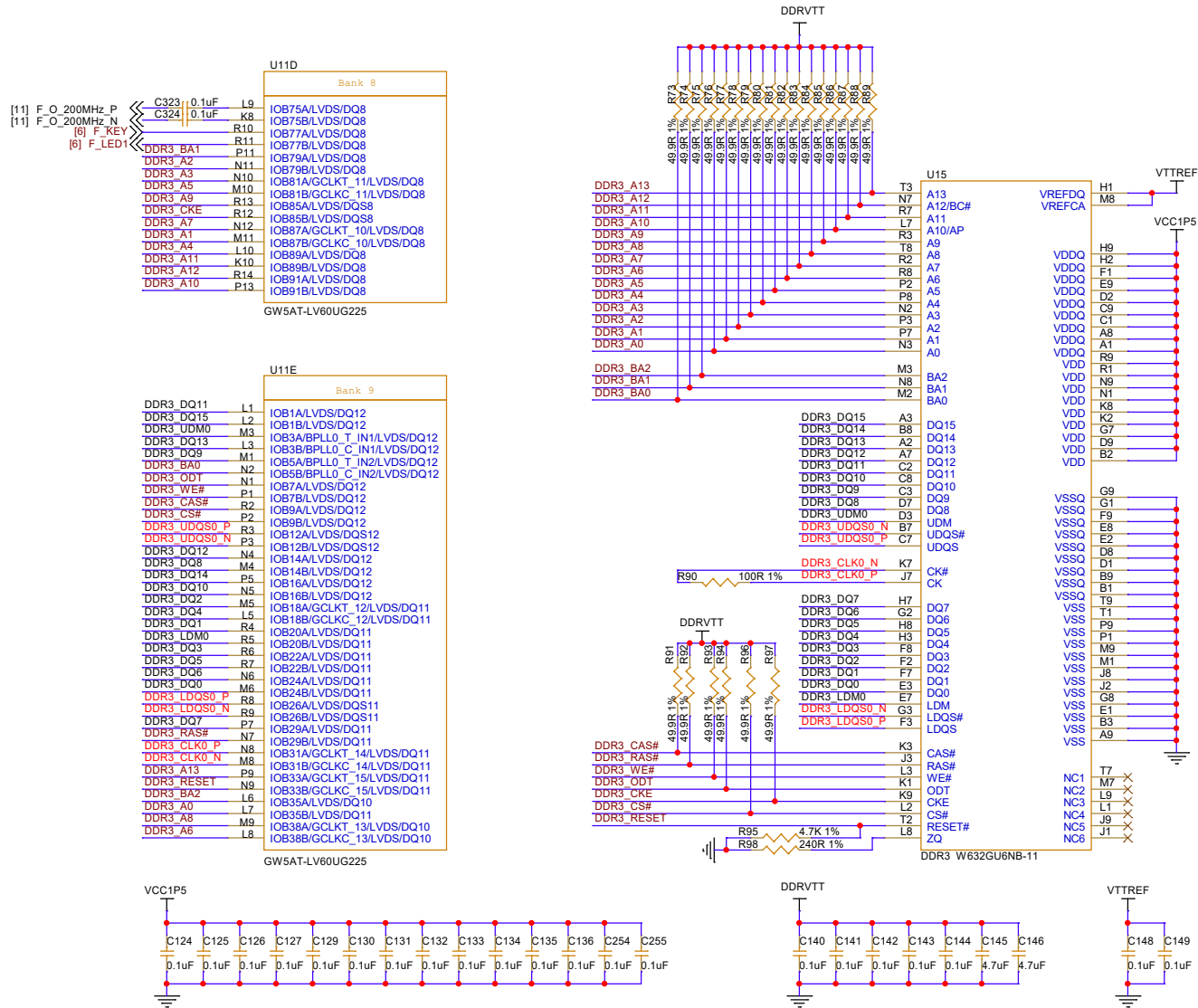

HDMI&USB to Download

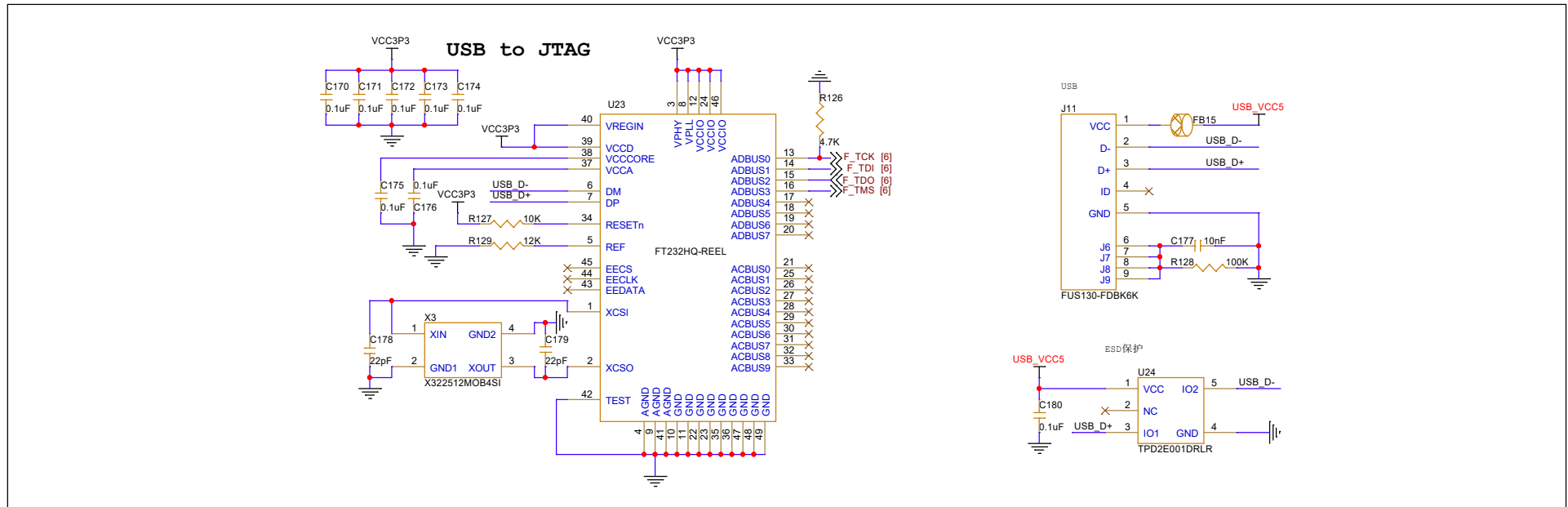
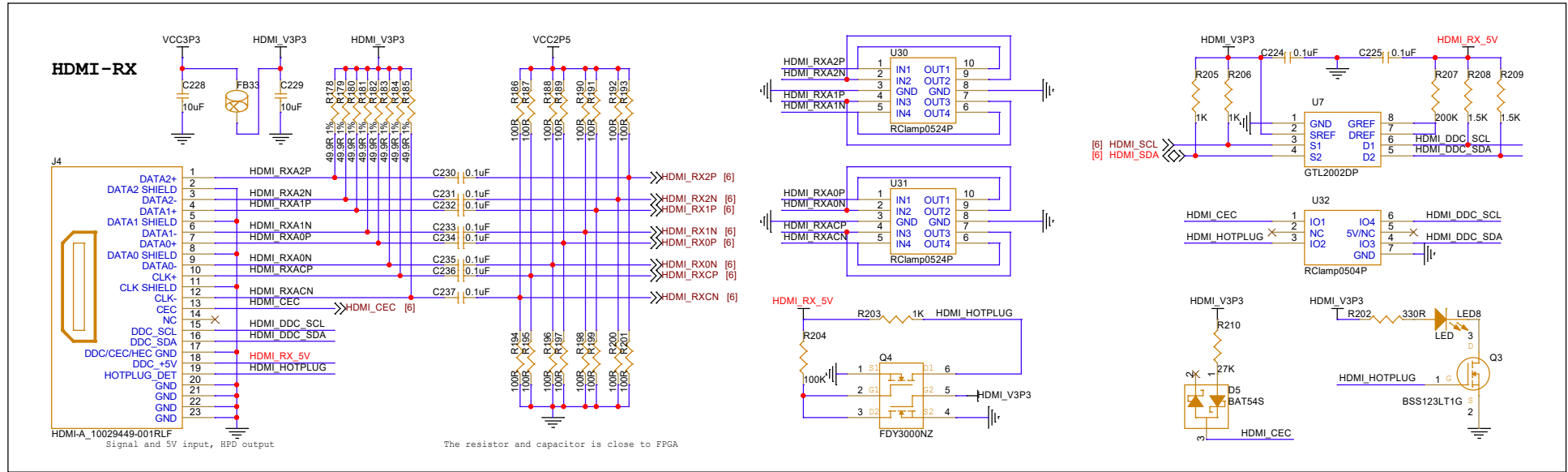

Title		
DK_USB_GW5AT-LV60UG225		
Size	Document Number	Rev
A3	HDMI,USB to Download	1.0
Date:	Thursday, August 01, 2024	Sheet 9 of 12

MIPI

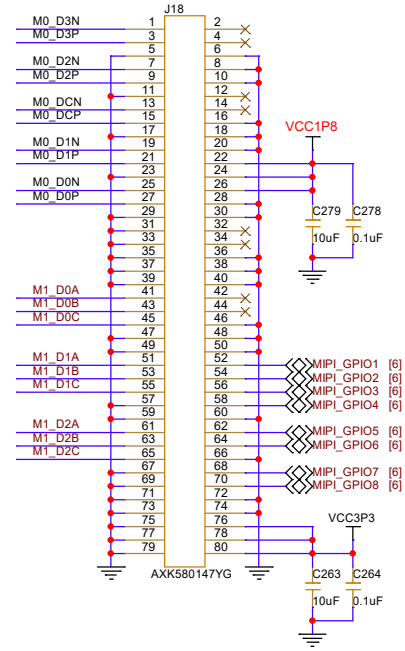
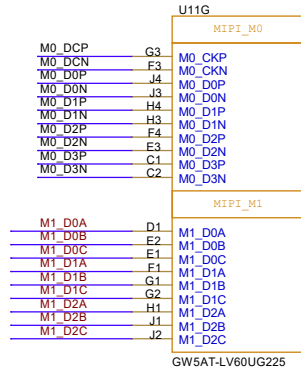

SDI

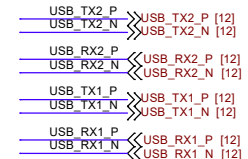
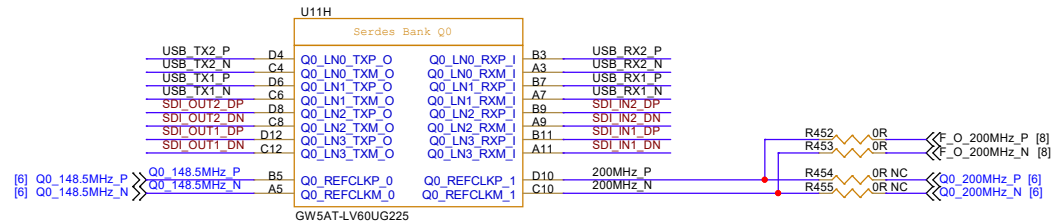
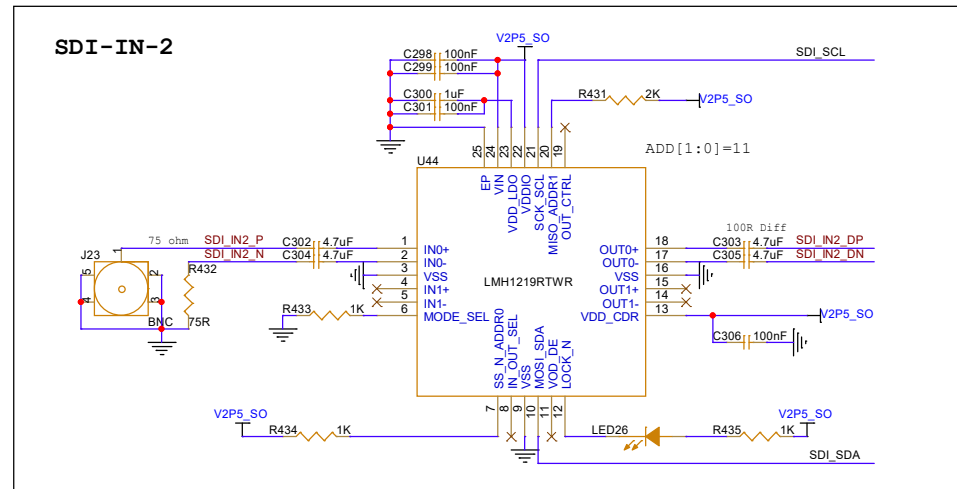
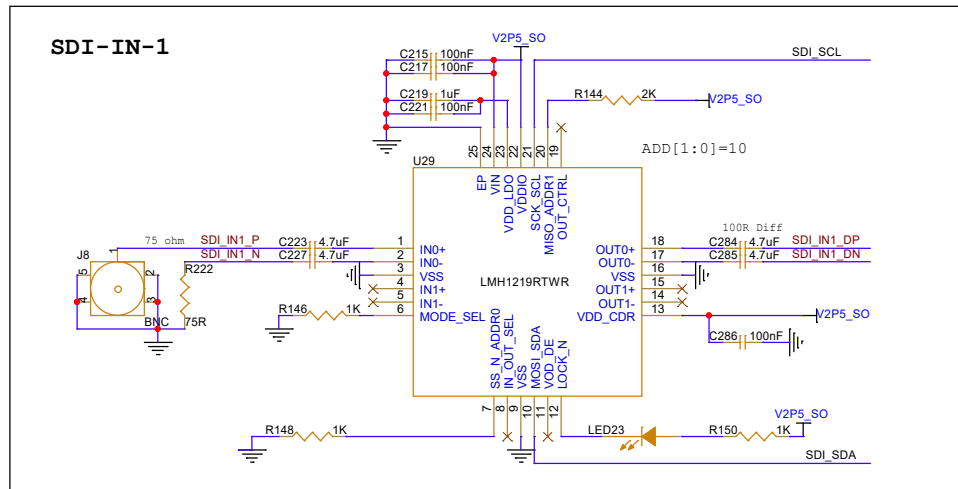
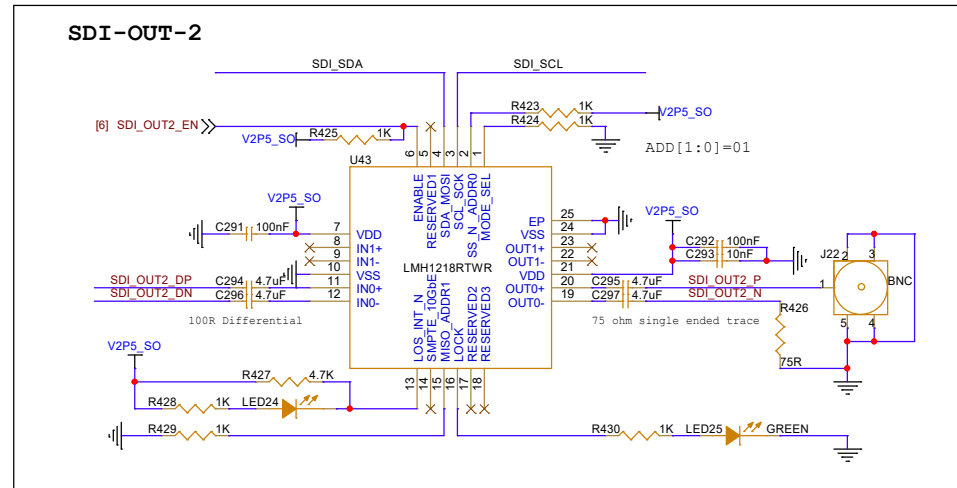
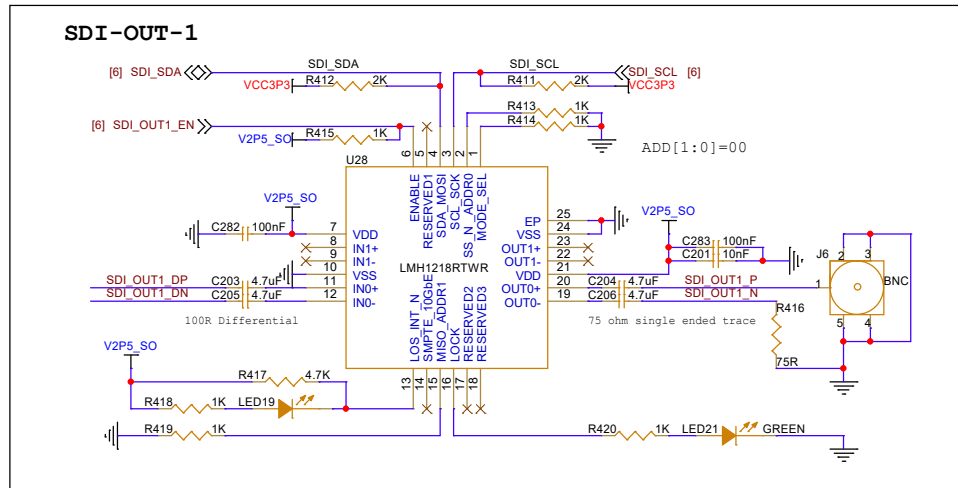

Title		
DK_USB_GW5AT-LV60UG225		
Size	Document Number	Rev
A3	SDI	1.0
Date:	Thursday, December 12, 2024	Sheet 11 of 12

Type-C

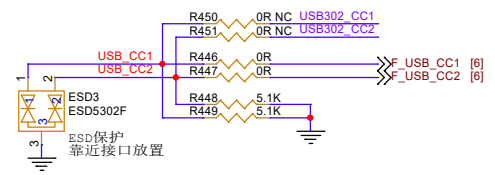
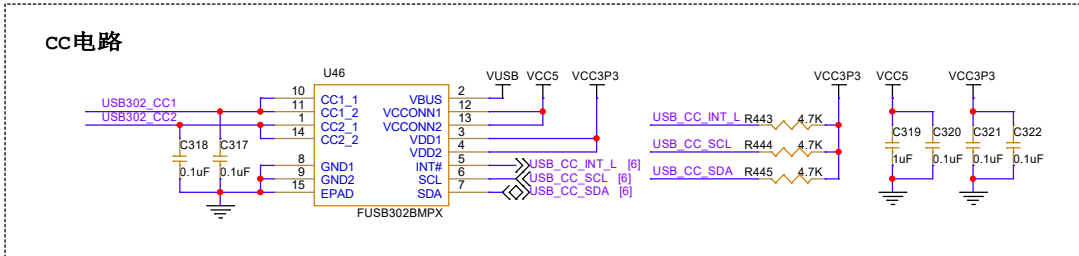
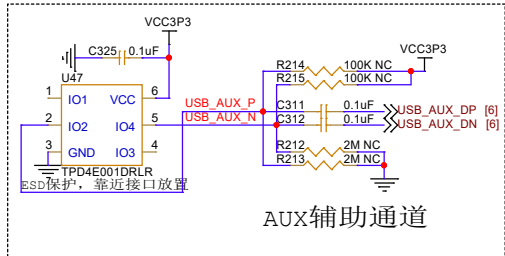
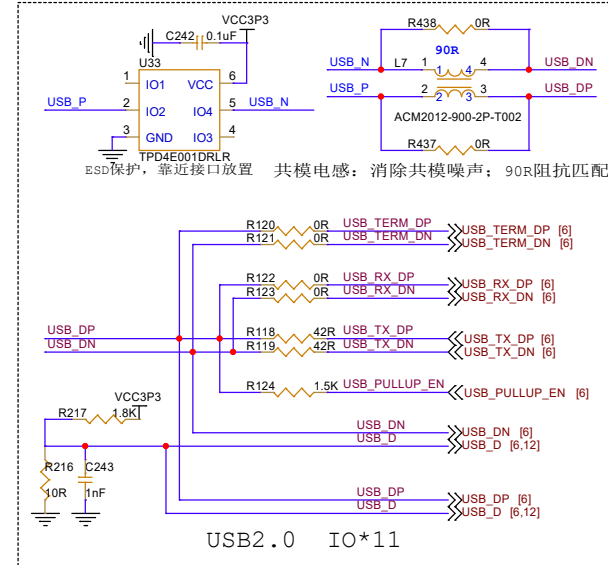
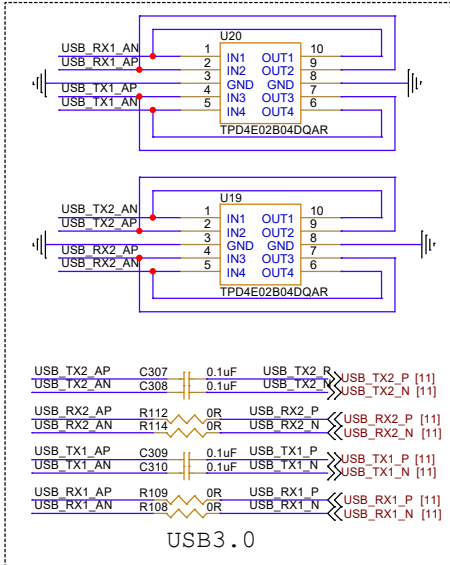
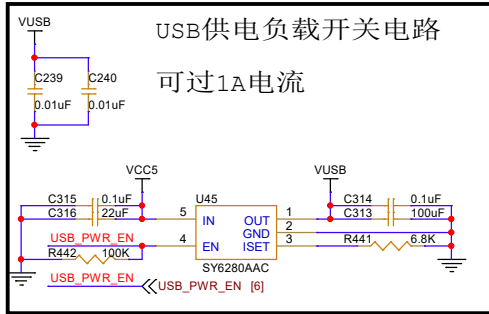
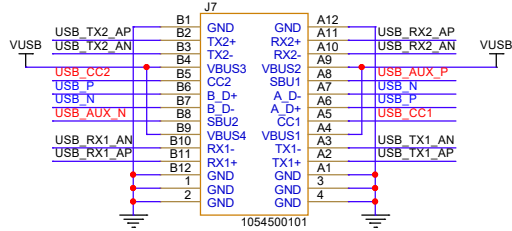

Title		DK_USB_GW5AT-LV60UG225
Size	Document Number	Rev
A3	Type-C	1.0
Date:	Monday, November 11, 2024	Sheet 12 of 12