



Gowin BSRAM & SSRAM User Guide

UG285-1.4E, 10/17/2025

Copyright © 2025 Guangdong Gowin Semiconductor Corporation. All Rights Reserved.

GOWIN is a trademark of Guangdong Gowin Semiconductor Corporation and is registered in China, the U.S. Patent and Trademark Office, and other countries. All other words and logos identified as trademarks or service marks are the property of their respective holders. No part of this document may be reproduced or transmitted in any form or by any means, electronic, mechanical, photocopying, recording or otherwise, without the prior written consent of GOWINSEMI.

Disclaimer

GOWINSEMI assumes no liability and provides no warranty (either expressed or implied) and is not responsible for any damage incurred to your hardware, software, data, or property resulting from usage of the materials or intellectual property except as outlined in the GOWINSEMI Terms and Conditions of Sale. GOWINSEMI may make changes to this document at any time without prior notice. Anyone relying on this documentation should contact GOWINSEMI for the current documentation and errata.

Revision History

Date	Version	Description
05/31/2018	1.09E	Initial version published.
08/17/2020	1.2E	The chapter structure modified and content optimized.
06/21/2021	1.3E	Some figures updated and "Help" information removed of chapter 6 IP Generation.
10/12/2021	1.3.1E	The description of RESET updated.
07/22/2022	1.3.2E	The disable mode and related devices of BSRAM updated.
08/10/2022	1.3.3E	The device information of SSRAM primitive updated.
11/01/2022	1.3.4E	GW1NS-2 removed.
01/05/2023	1.3.5E	The configuration box "File" modified to "General" and "Device Version" option added on the IP interface.
05/25/2023	1.3.6E	<ul style="list-style-type: none">● Read-before-write in dual port mode is not supported.● Notes added in the functional description of dual port mode and semi dual port mode respectively.
05/22/2024	1.3.7E	<ul style="list-style-type: none">● "Figure 3-2 Timing Diagram of DPB/DPX9B Normal Write (Port B for Write and Port A for Read, Bypass Read)" and "Figure 3-4 Timing Diagram of DPB/DPX9B Normal Write (Port B for Write and Port A for Read, Pipeline Read)" added.● Notes for functional descriptions of dual port mode and semi dual port mode modified.
07/25/2025	1.3.8E	"Figure 5-1 Timing Diagram of RAM16S1" updated.
08/29/2025	1.3.9E	<ul style="list-style-type: none">● Note added to "Table 2-2 BSRAM Data Width and Address Width".● "Figure 5-5 Timing Diagram of RAM16SDP1" updated.
10/17/2025	1.4E	Notes for BSRAM and SSRAM added.

Contents

Contents	i
List of Figures	
List of Tables	
1 About This Guide	1
1.1 Purpose	1
1.2 Related Documents	1
1.3 Abbreviations and Terminology.....	1
1.4 Support and Feedback	2
2 Overview	3
2.1 Features.....	3
2.2 Configuration Mode	4
3 BSRAM Primitives	6
3.1 Dual Port Mode.....	6
3.2 Single Port Mode	18
3.3 Semi Dual Port Mode.....	24
3.4 Read-only Mode	30
4 BSRAM Output Reset	35
5 SSRAM Primitives	38
5.1 RAM16S1	38
5.2 RAM16S2	41
5.2.1 RAM16S4	43
5.3 RAM16SDP1	45
5.4 RAM16SDP2	48
5.5 RAM16SDP4	51
5.6 ROM16	53
6 IP Generation	56
6.1 BSRAM Dual-port Mode	56
6.2 SSRAM Single-port Mode	58
7 Initialization File	61
7.1 Bin File.....	61

7.2 Hex File.....	61
7.3 Hex File with Address	62

List of Figures

Figure 3-1 Timing Diagram of DPB/DPX9B Normal Write(Bypass Read)	7
Figure 3-2 Timing Diagram of DPB/DPX9B Normal Write (Port B for Write and Port A for Read, Bypass Read)	8
Figure 3-3 Timing Diagram of DPB/DPX9B Normal Write(Pipeline Read)	9
Figure 3-4 Timing Diagram of DPB/DPX9B Normal Write (Port B for Write and Port A for Read, Pipeline Read)	10
Figure 3-5 Timing Diagram of DPB/DPX9B Write-Through(Bypass Read)	11
Figure 3-6 Timing Diagram of DPB/DPX9B Write-Through(Pipeline Read)	12
Figure 3-7 DPB/DPX9B Diagram	13
Figure 3-8 Timing Diagram of SP/SPX9 Read-before-write(Bypass Read)	19
Figure 3-9 Timing Diagram of SP/SPX9 Read-before-write(Pipeline Read)	19
Figure 3-10 SP/SPX9 Port Diagram	20
Figure 3-11 Timing Diagram of Semi Dual Port BSRAM Normal Write(Bypass Read)	24
Figure 3-12 Timing Diagram of Semi Dual Port BSRAM Normal Write(Pipeline Read)	25
Figure 3-13 SDPB/SDPX9B Diagram	26
Figure 3-14 Timing Diagram of ROM(Bypass Read)	30
Figure 3-15 Timing Diagram of ROM(Pipeline Read)	31
Figure 3-16 pROM/pROMX9 Diagram	31
Figure 4-1 Reset Diagram	35
Figure 4-2 Timing Diagram of Synchronous Reset(Pipeline)	36
Figure 4-3 Timing Diagram of Synchronous Reset(Bypass)	36
Figure 4-4 Timing Diagram of Asynchronous Reset(Pipeline)	36
Figure 4-5 Timing Diagram of Asynchronous Reset(Bypass)	37
Figure 5-1 Timing Diagram of RAM16S1	39
Figure 5-2 RAM16S1Blcok Diagram	39
Figure 5-3 RAM16S2 Port Diagram	41
Figure 5-4 RAM16S4 Diagram	43
Figure 5-5 Timing Diagram of RAM16SDP1	46
Figure 5-6 RAMSDP1 Port Diagram	46
Figure 5-7 RAM16SDP2 Port Diagram	48
Figure 5-8 RAMSDP4 Diagram	51
Figure 5-9 Timing Diagram of ROM16	53

Figure 5-10 ROM16 Port Diagram	54
Figure 6-1 IP Customization of DPB	57
Figure 6-2 IP Customization of RAM16S	59

List of Tables

Table 1-1 Abbreviations and Terminology	1
Table 2-1 Configuration Mode.....	4
Table 2-2 BSRAM Data Width and Address Width	4
Table 2-3 Data Width in Dual Port Mode	5
Table 2-4 Data Width in Semi Dual Port Mode	5
Table 3-1 Configuration Relationship of Data Width and Address Depth	12
Table 3-2 Port Description.....	13
Table 3-3 Parameter Description	14
Table 3-4 Configuration Relationship of Data Width and Address Depth	19
Table 3-5 Port Description.....	20
Table 3-6 Parameter Description	21
Table 3-7 Configuration Relationship of Data Width and Address Depth	25
Table 3-8 Port Description.....	26
Table 3-9 Parameter Description	26
Table 3-10 Configuration Relationship of Data Width and Address Depth	31
Table 3-11 Port Description.....	32
Table 3-12 Parameter Description	32
Table 5-1 Shadow Memory Mode	38
Table 5-2 Port Description.....	39
Table 5-3 Parameter Description	40
Table 5-4 Port Description.....	41
Table 5-5 Parameter Description	42
Table 5-6 Port Description.....	44
Table 5-7 Parameter Description	44
Table 5-8 Port Description.....	46
Table 5-9 Parameter Description	47
Table 5-10 Port Description.....	48
Table 5-11 Parameter Description.....	49
Table 5-12 Port Description.....	51
Table 5-13 Parameter Description	52
Table 5-14 Port Description.....	54
Table 5-15 Parameter Description	54

1 About This Guide

1.1 Purpose

This manual describes the features, operating modes, primitives and IP generation of Gowin BSRAM & SSRAM to help you better understand Gowin products.

1.2 Related Documents

The latest user guides are available on GOWINSEMI Website. You can find the related documents at www.gowinsemi.com:

- [DS100, GW1N series of Products Data Sheet](#)
- [DS117, GW1NR series of FPGA Products Data Sheet](#)
- [DS102, GW2A series of FPGA Products Data Sheet](#)
- [DS226, GW2AR series of FPGA Products Data Sheet](#)
- [SUG100, Gowin Software User Guide](#)

1.3 Abbreviations and Terminology

The abbreviations and terminology used in this manual are shown in Table 1-1.

Table 1-1 Abbreviations and Terminology

Abbreviations and Terminology	Name
BSRAM	Block Static Random Access Memory
CFU	Configurable Function Unit
CST	Constraints
DP	True Dual Port 16K Block SRAM
ROM	Read-only Memory
SDP	Semi Dual Port 16K Block SRAM
SP	Single Port 16K Block SRAM
SSRAM	Shadow Static Random Access Memory

1.4 Support and Feedback

Gowin Semiconductor provides customers with comprehensive technical support. If you have any questions, comments, or suggestions, please feel free to contact us directly using the information provided below.

Website: www.gowinsemi.com

E-mail: support@gowinsemi.com

2 Overview

GOWINSEMI FPGA products provide abundant memories, including BSRAM and SSRAM.

Each BSRAM can be configured with up to 18 Kbits. Data width and address depth can also be configured. Each BSRAM has two ports: Port A and Port B. Either port can be a read or write port. They have independent clocks, addresses, data, and control signals, and they share the same storage memory.

Configurable Function Unit (CFU) is a basic unit that composes Gowin FPGA products. It can be configured as SSRAM, including 16 x 4 bits SRAM or ROM16.

2.1 Features

- Each BSRAM can store up to 18Kbits of data.
- Supports up to 380MHz (230MHz in read-before-write mode).
- Supports Single Port mode (SP).
- Supports Dual Port mode (DP).
- Supports Semi-dual Port mode (SDP).
- Supports Read-only-mode (ROM).
- Supports up to 36 bits data width.
- Dual Port and Semi-dual Port support independent clocks and independent data width.
- Supports pipeline mode and bypass mode.
- Supports normal mode, write-through mode, and read-before-write mode.

2.2 Configuration Mode

Each BSRAM can be configured as 16 Kbits or 18 Kbits. Data width and address depth configuration is as shown in Table 2-1.

Table 2-1 Configuration Mode

Size	Single Port Mode	Dual Port Mode	Semi-dual Port Mode	Read Only Mode
16Kbits	16K x 1	16K x 1	16K x 1	16K x 1
	8K x 2	8K x 2	8K x 2	8K x 2
	4K x 4	4K x 4	4K x 4	4K x 4
	2K x 8	2K x 8	2K x 8	2K x 8
	1K x 16	1K x 16	1K x 16	1K x 16
	512 x 32	-	512 x 32	512 x 32
18Kbits	2K x 9	2K x 9	2K x 9	2K x 9
	1K x 18	1K x 18	1K x 18	1K x 18
	512 x 36	-	512 x 36	512 x 36

Each BSRAM has 14-bit address line, that is AD[13:0], and the maximum address depth is 16,384. Different data widths use different address lines, as shown in Table 2-2.

Table 2-2 BSRAM Data Width and Address Width

Size	Mode	Data Width ^[1]	Address Depth	Address Width
16Kbits	16K x 1	[0:0]	16,384	[13:0]
	8K x 2	[1:0]	8,192	[13:1]
	4K x 4	[3:0]	4,096	[13:2]
	2K x 8	[7:0]	2,048	[13:3]
	1K x 16	[15:0]	1,024	[13:4]
	512 x 32	[31:0]	512	[13:5]
18Kbits	2K x 9	[8:0]	2,048	[13:3]
	1K x 18	[17:0]	1,024	[13:4]
	512 x 36	[35:0]	512	[13:5]

Note!

The BSRAM of C version GW1N-9/GW1NR-9 devices does not support data widths of 1 bit and 2 bits.

Dual Port and Semi-dual Port support independent read/write clocks and independent read/write data width. In Dual Port mode, the data widths supported by Port A and Port B are as shown in Table 2-3. In Semi-dual Port mode, the data widths supported by Port A and Port B are as shown in Table 2-4.

Table 2-3 Data Width in Dual Port Mode

Size	Port B	Port A						
		16K x 1	8K x 2	4K x 4	2K x 8	1K x 16	2K x 9	1K x 18
16Kbits	16K x 1	Yes	Yes	Yes	Yes	Yes	N/A	N/A
	8K x 2	Yes	Yes	Yes	Yes	Yes	N/A	N/A
	4K x 4	Yes	Yes	Yes	Yes	Yes	N/A	N/A
	2K x 8	Yes	Yes	Yes	Yes	Yes	N/A	N/A
	1K x 16	Yes	Yes	Yes	Yes	Yes	N/A	N/A
18Kbits	2K x 9	N/A	N/A	N/A	N/A	N/A	Yes	Yes
	1K x 18	N/A	N/A	N/A	N/A	N/A	Yes	Yes

Table 2-4 Data Width in Semi Dual Port Mode

Size	Port B	Port A								
		16K x 1	8K x 2	4K x 4	2K x 8	1K x 16	512 x 32	2K x 9	1K x 18	512 x 36
16Kbits	16K x 1	Yes	Yes	Yes	Yes	Yes	Yes	N/A	N/A	N/A
	8K x 2	Yes	Yes	Yes	Yes	Yes	Yes	N/A	N/A	N/A
	4K x 4	Yes	Yes	Yes	Yes	Yes	Yes	N/A	N/A	N/A
	2K x 8	Yes	Yes	Yes	Yes	Yes	Yes	N/A	N/A	N/A
	1K x 16	Yes	Yes	Yes	Yes	Yes	Yes	N/A	N/A	N/A
	512 x 32	Yes	Yes	Yes	Yes	Yes	Yes	N/A	N/A	N/A
18Kbits	2K x 9	N/A	N/A	N/A	N/A	N/A	N/A	Yes	Yes	Yes
	1K x 18	N/A	N/A	N/A	N/A	N/A	N/A	Yes	Yes	Yes

3 BSRAM Primitives

BSRAM includes single port mode (SP/SPX9), dual port mode (DPB/DPX9B), semi-dual mode (SDPB/SDPX9B), and read-only mode (pROM/pROMX9).

Note!

- GW1N-9/GW1NR-9/GW1N-1S/GW1NS-4/GW1NS-4C/GW1NSR-4/GW1NSR-4C/GW1NSER-4C do not support dual port mode.
- For GW1N-9/GW1NR-9/GW1N-1S/GW1NS-4/GW1NS-4C/GW1NSR-4/GW1NSR-4C/GW1NSER-4C, the 32/36-bit SP/SPX9 is divided into two SP/SPX9s, which occupy two BSRAMs.
- GW1NZ-1/GW1NZ-1C do not support dual port mode with 1/2/4/8/9 bit widths.
- The dual port BSRAM of all 55nm devices (including GW1N(*), GW2A(*), and GW1A(*)) does not support the read-before-write mode.
- GW1N-4/GW1NR-4/GW1NRF-4B/GW1N-4B/GW1NR-4B do not support ROM mode, and do not support BSRAM initialization value assignment in single port mode, dual port mode, or semi dual port mode.

3.1 Dual Port Mode

Primitive

DPB/DPX9B (True Dual Port 16K BSRAM/True Dual Port 18K BSRAM)

Functional Description

DPB/DPX9B works in dual port mode with its memory space of 16K bit/18K bit. Port A and port B support read/write operations respectively^[1]. DPB/DPX9B supports 2 read modes (bypass mode and pipeline mode) and 2 write modes (normal mode and write-through mode).

Note!

[1] Performing read and write operations to the same address at the same time is not allowed.

- Read Mode

The output pipeline register at A port and B port are configured by READ_MODE0 and READ_MODE1. When the output pipeline register is used, the read operation needs extra delay cycle.

- Write Mode

The write mode at A and B is configured by WRITE_MODE0 and WRITE_MODE1. The modes include normal mode and write-through mode. The corresponding timing diagram of different modes is shown from Figure 3-1 to Figure 3-6.

Figure 3-1 Timing Diagram of DPB/DPX9B Normal Write(Bypass Read)

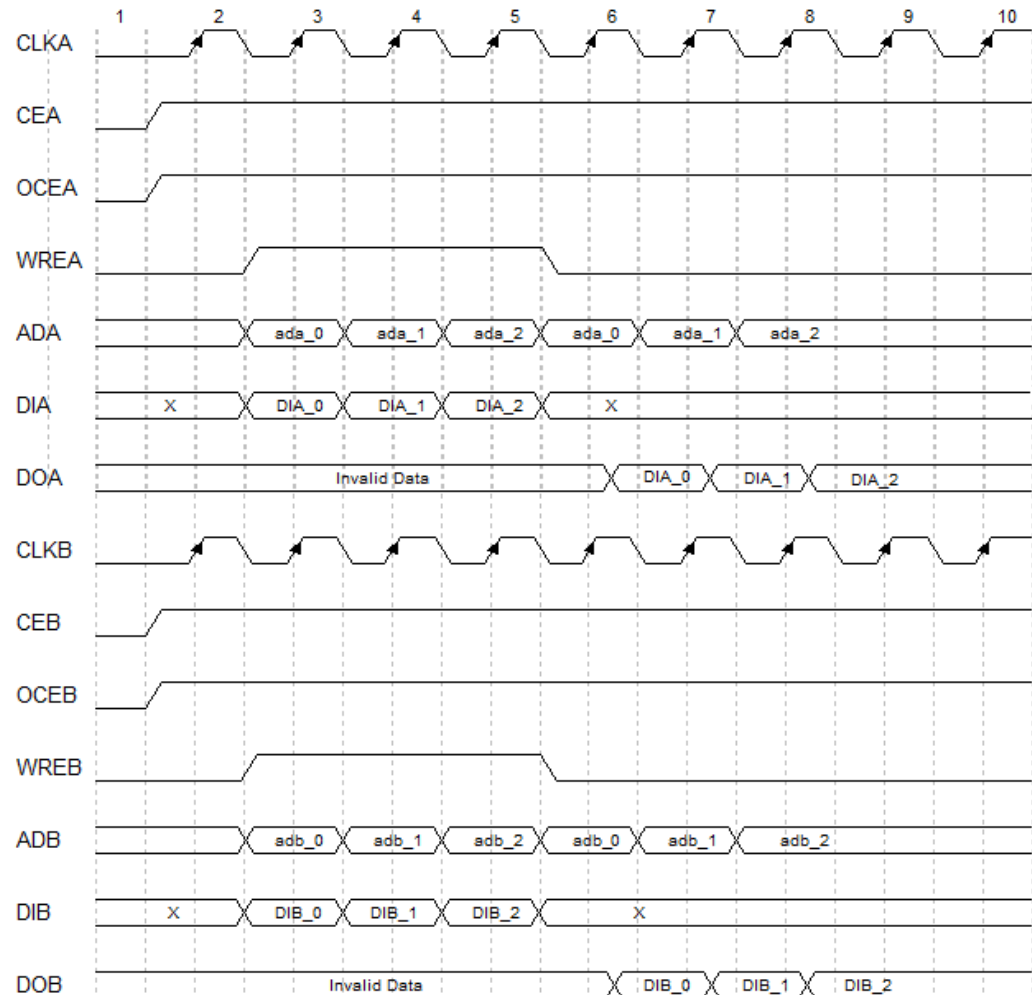

Figure 3-2 Timing Diagram of DPB/DPX9B Normal Write (Port B for Write and Port A for Read, Bypass Read)

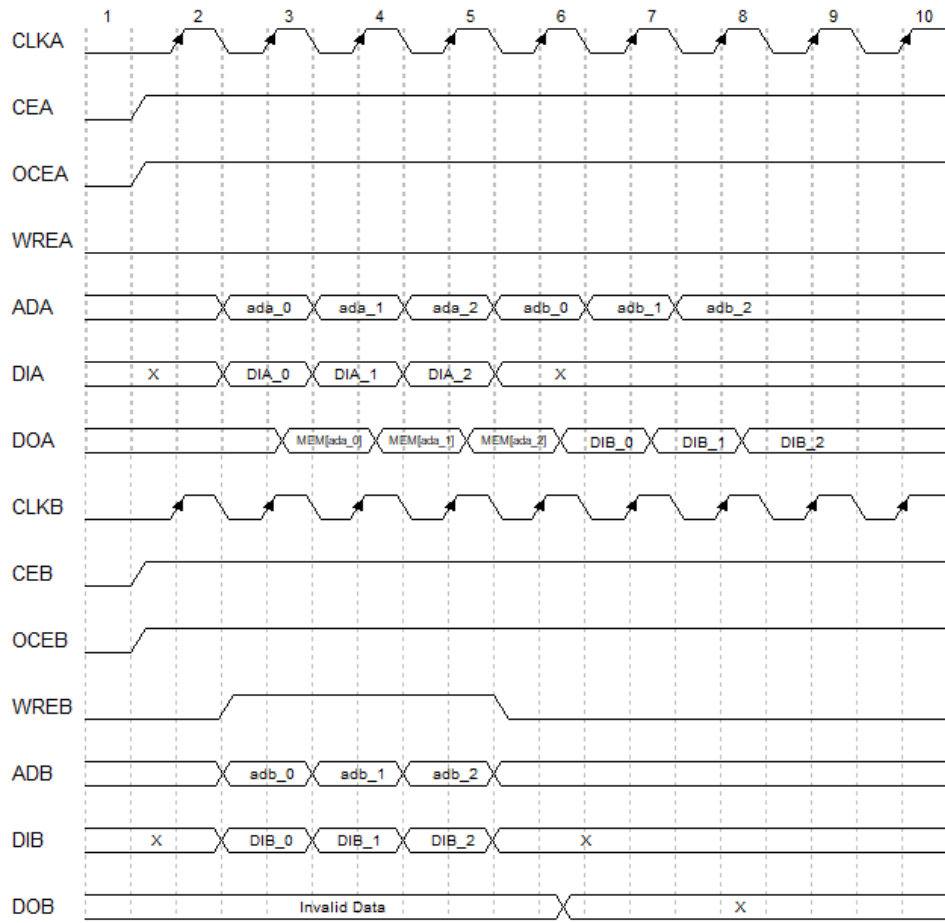

Figure 3-3 Timing Diagram of DPB/DPX9B Normal Write(Pipeline Read)

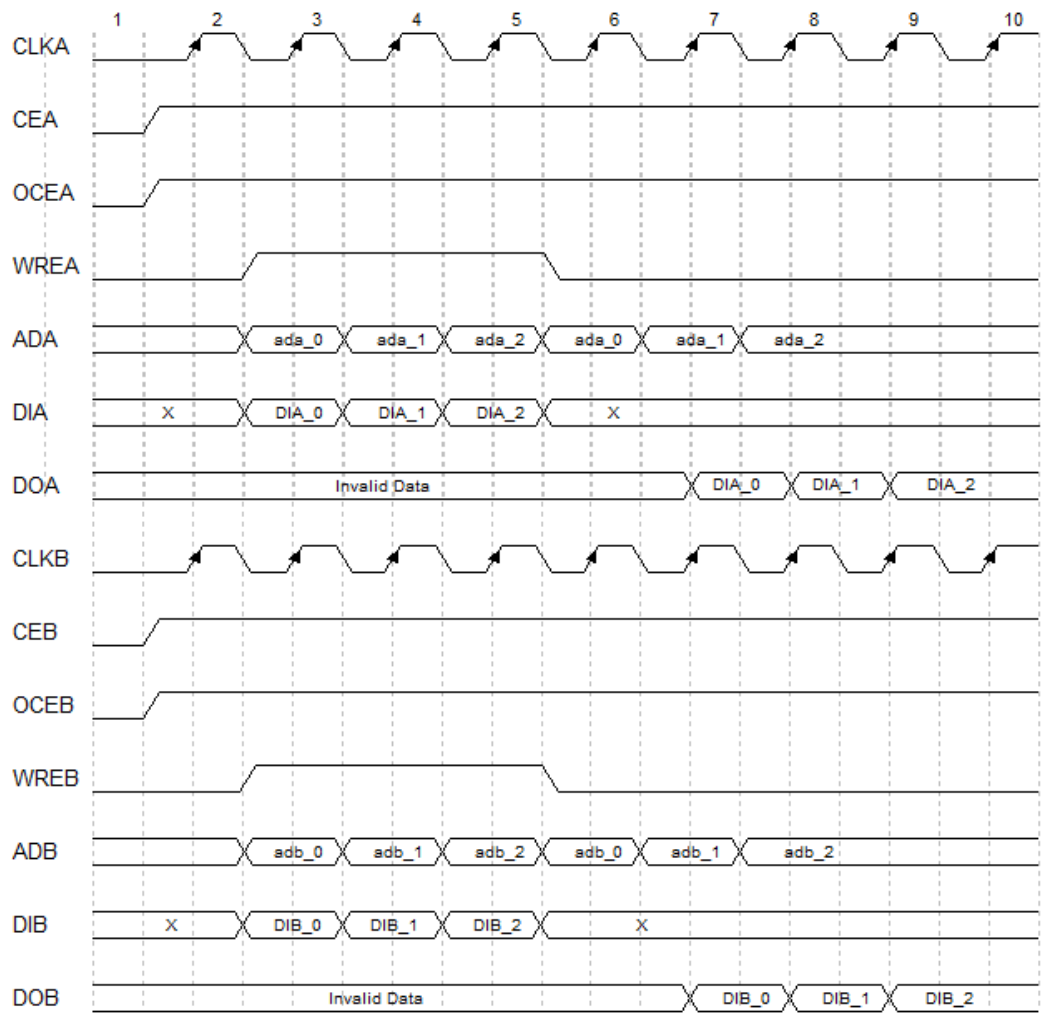

Figure 3-4 Timing Diagram of DPB/DPX9B Normal Write (Port B for Write and Port A for Read, Pipeline Read)

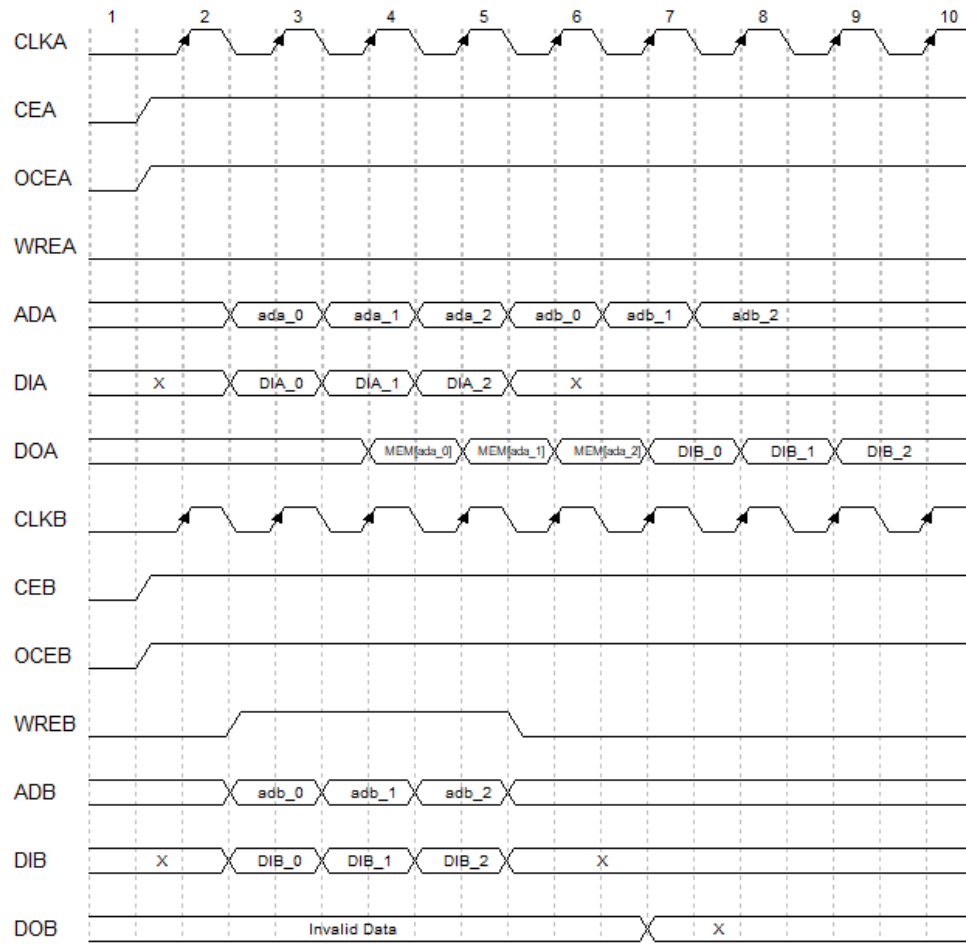

Figure 3-5 Timing Diagram of DPB/DPX9B Write-Through(Bypass Read)

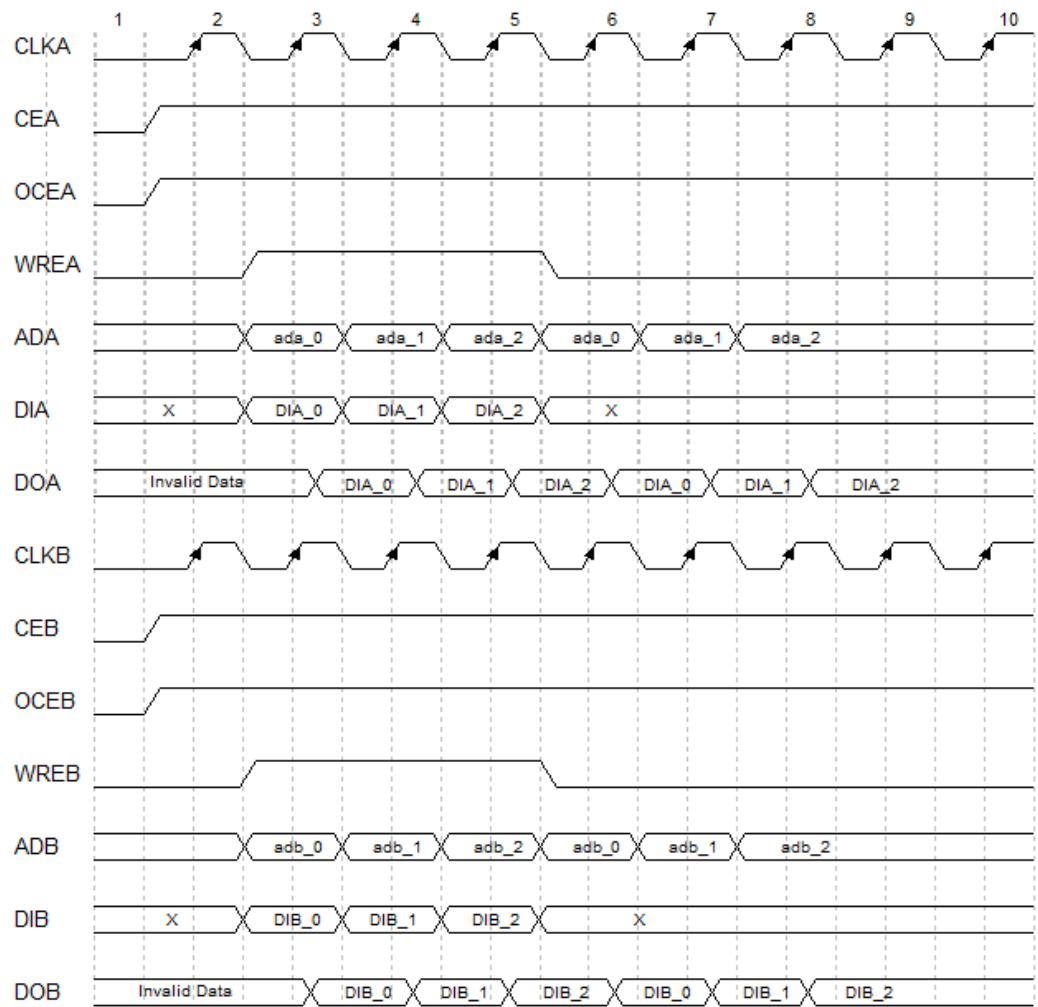
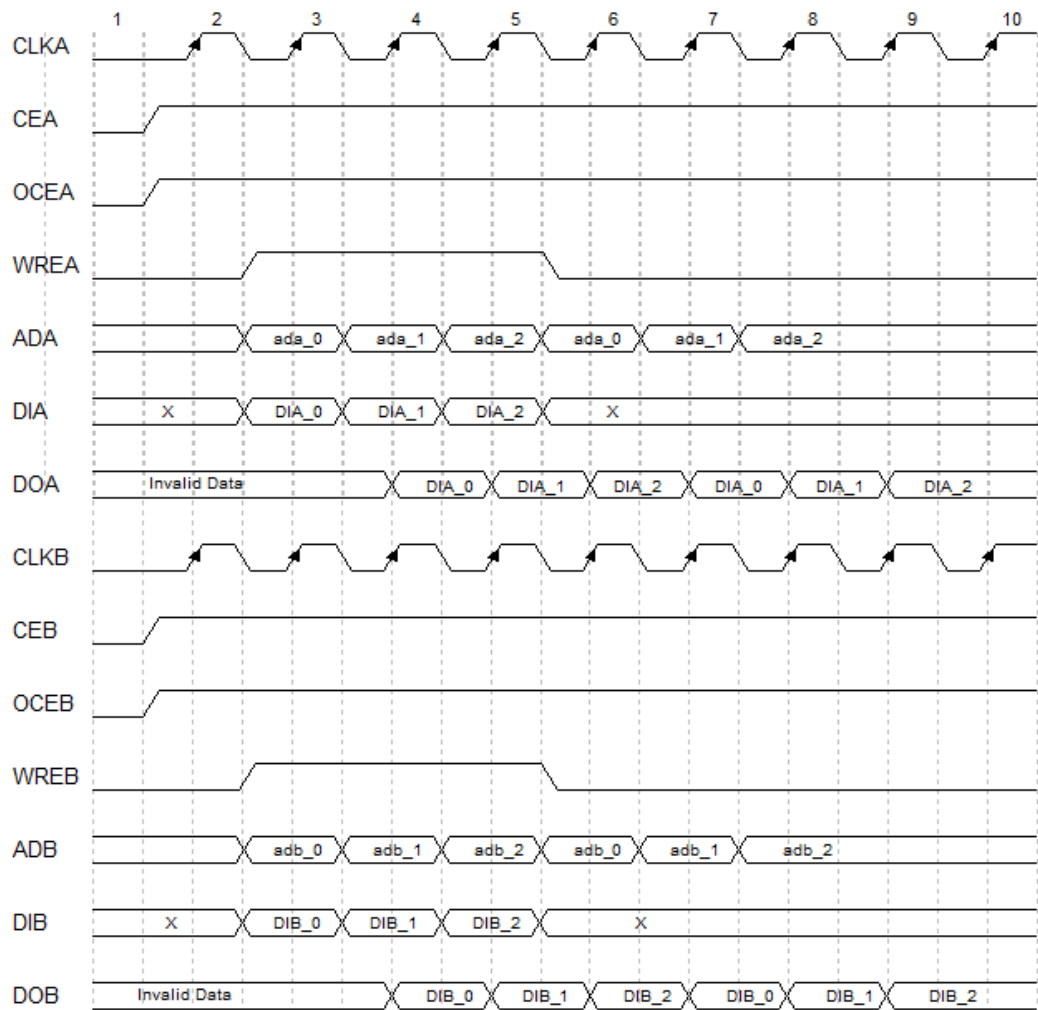

Figure 3-6 Timing Diagram of DPB/DPX9B Write-Through(Pipeline Read)



Configuration Relationship

Table 3-1 Configuration Relationship of Data Width and Address Depth

Dual Port Mode	BSRAM Capacity	Data Width	Address Depth
DPB	16K	1	14
		2	13
		4	12
		8	11
		16	10
DPX9B	18K	9	11
		18	10

Port Diagram

Figure 3-7 DPB/DPX9B Diagram

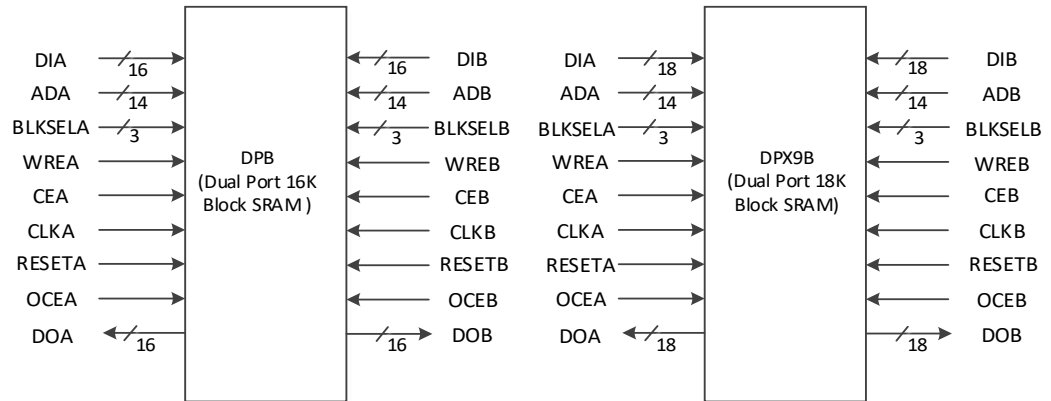

Port Description

Table 3-2 Port Description

Name	I/O	Description
DOA[15:0]/DOA[17:0]	Output	A data output
DOB[15:0]/DOB[17:0]	Output	B data output
DIA[15:0]/DIA[17:0]	Input	A data input
DIB[15:0]/DIB[17:0]	Input	B data input
ADA[13:0]	Input	A address input
ADB[13:0]	Input	B address input
WREA	Input	A write enable input 1: write 0: read
WREB	Input	B write enable input 1: write 0: read
CEA	Input	A clock enable signal, active-high
CEB	Input	B clock enable signal, active-high
CLKA	Input	A clock input
CLKB	Input	B clock input
RESETA	Input	A reset input, synchronous reset and asynchronous reset supported, active-high. It is the RESETA reset register, rather than the value of reset register.
RESETB	Input	B reset input, synchronous reset and asynchronous reset supported, active-high. It is the RESETB reset register, rather than the value of reset register.
OCEA	Input	A output clock enable signal used in Pipeline, invalid in Bypass

Name	I/O	Description
OCEB	Input	B output clock enable signal used in Pipeline, invalid in Bypass
BLKSELA[2:0]	Input	BSRAM A block selection signal for multiple BSRAM memory units cascading to realize capacity expansion
BLKSELB[2:0]	Input	BSRAM B block selection signal for multiple BSRAM memory units cascading to realize capacity expansion

Parameter

Table 3-3 Parameter Description

Name	Type	Range	Default	Description
READ_MODE0	Integer	1'b0,1'b1	1'b0	A read mode configuration 1'b0:bypass 1'b1:pipeline
READ_MODE1	Integer	1'b0,1'b1	1'b0	B read mode configuration 1'b0:bypass 1'b1:pipeline
WRITE_MODE0	Integer	2'b00,2'b01	2'b00	A write mode configuration 2'b00: normal 2'b01: write-through
WRITE_MODE1	Integer	2'b00,2'b01	2'b00	B write mode configuraion 2'b00: normal 2'b01: write-through
BIT_WIDTH_0	Integer	DPB:1,2,4,8,16 DPX9B:9,18	DPB:16 DPX9B:18	A data width configuration
BIT_WIDTH_1	Integer	DPB:1,2,4,8,16 DPX9B:9,18	DPB:16 DPB:18	B data width configuration
BLK_SEL_0	Integer	3'b000~3'b111	3'b000	When BSRAM A block selection parameter is equal to BLKSELA, the BSRAM is selected. The software will handle expansion automatically when IP Core Generator is used to expand storage capacity.

Name	Type	Range	Default	Description
BLK_SEL_1	Integer	3'b000~3'b111	3'b000	When BSRAM B block selection parameter is equal to BLKSELB, the BSRAM is selected. The software will handle expansion automatically when IP Core Generator is used to expand storage capacity.
RESET_MODE	String	SYNC,ASYNC	SYNC	Reset mode configuration SYNC: synchronous reset ASYNC: asynchronous reset
INIT_RAM_00~ INIT_RAM_3F	Integer	DPB:256'h0...0~256'h1...1 DPX9B:288'h0...0~288'h1...1	DPB:256'h0...0 DPX9B:288'h0...0	Used to set BSRAM initialization data

Primitive Instantiation

You can instantiate the primitives directly or generate them through IP Core Generator. For details, see chapter [6 IP Generation](#). Take DPB as an example to introduce the instantiation.

Verilog Instantiation:

```
DPB bram_dpb_0 (
    .DOA({doa[15:8],doa[7:0]}),
    .DOB({doa[15:8],dob[7:0]}),
    .CLKA(clka),
    .OCEA(ocea),
    .CEA(cea),
    .RESETA(reseta),
    .WREA(wrea),
    .CLKB(clkb),
    .OCEB(oceb),
    .CEB(ceb),
```

```

        .RESETB(resetb),
        .WREB(wreb),
        .BLKSELA({3'b000}),
        .BLKSELB({3'b000}),
        .ADA({ada[10:0],3'b000}),
        .DIA({{8{1'b0}},dia[7:0]})
        .ADB({adb[10:0],3'b000}),
        .DIB({{8{1'b0}},dib[7:0]})
    );
    defparam bram_dpb_0.READ_MODE0 = 1'b0;
    defparam bram_dpb_0.READ_MODE1 = 1'b0;
    defparam bram_dpb_0.WRITE_MODE0 = 2'b00;
    defparam bram_dpb_0.WRITE_MODE1 = 2'b00;
    defparam bram_dpb_0.BIT_WIDTH_0 = 8;
    defparam bram_dpb_0.BIT_WIDTH_1 = 8;
    defparam bram_dpb_0.BLK_SEL_0 = 3'b000;
    defparam bram_dpb_0.BLK_SEL_1 = 3'b000;
    defparam bram_dpb_0.RESET_MODE = "SYNC";

    defparam bram_dpb_0.INIT_RAM_00 =
    256'h00A0000000000000B00A000000000000B00A000000000000B00A00
    0000000000B;

    defparam bram_dpb_0.INIT_RAM_3E =
    256'h00A0000000000000B00A000000000000B00A000000000000B00A00
    0000000000B;

    defparam bram_dpb_0.INIT_RAM_3F =
    256'h00A0000000000000B00A000000000000B00A000000000000B00A00
    0000000000B;

```

Vhdl Instantiation:

```
COMPONENT DPB
```

```
    GENERIC (
```

```

        BIT_WIDTH_0:integer:=16;
        BIT_WIDTH_1:integer:=16;
        READ_MODE0:bit:='0';
        READ_MODE1:bit:='0';
        WRITE_MODE0:bit_vector:="00";
        WRITE_MODE1:bit_vector:="00";
        BLK_SEL_0:bit_vector:="000";

```



```

)
PORT MAP(
    DOA=>doa,
    DOB=>dob,
    CLKA=>clka,
    CLKB=>clkb,
    CEA=>ceb,
    CEB=>ceb,
    OCEA=>ocea,
    OCEB=>oceb,
    RESETA=>reseta,
    RESETB=>resetb,
    WREA=>wrea,
    WREB=>wreb,
    ADA=>ada,
    ADB=>adb,
    BLKSELA=>blksela,
    BLKSELB=>blkselb,
    DIA=>dia,
    DIB=>dib
);

```

3.2 Single Port Mode

Primitive

SP/SPX9 (Single Port 16K BSRAM/Single Port 18K BSRAM)

Functional Description

SP/SPX9 works in single port mode with a memory capacity of 16K bit/18K bit. The read/write operation of the single port is controlled by a clock. SP/SPX9 supports two read modes (bypass mode and pipeline mode) and three write modes (normal mode, write-through mode and read-before-write mode).

- Read mode

The output pipeline register is configured by READ_MODE. When the output pipeline register is used, the read operation needs extra delay cycle.

- Write mode

Normal mode, write-through mode, and read-before-write mode are configured by WRITE_MODE.

For the timing diagram of single port BSRAM different read/write modes, see the dual port BSRAM A/B ports timing diagram from Figure 3-1 to Figure 3-6, Figure 3-8 and Figure 3-9.

Figure 3-8 Timing Diagram of SP/SPX9 Read-before-write(Bypass Read)

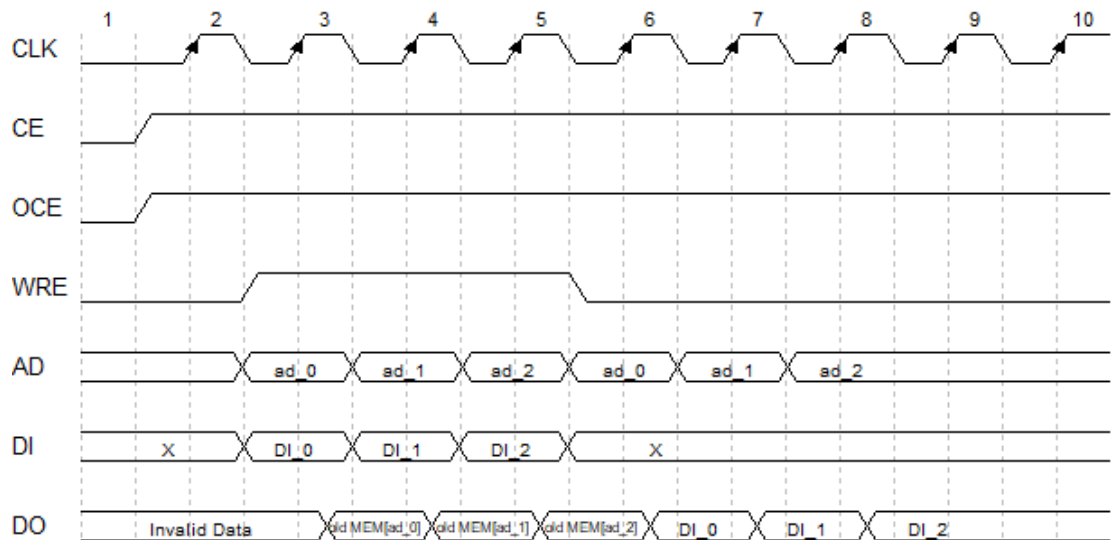
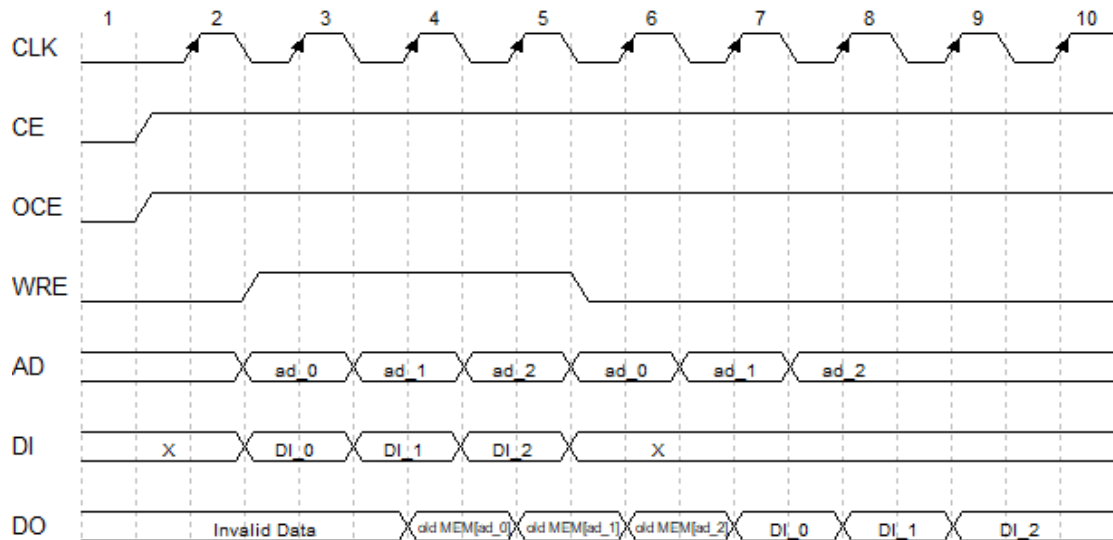

Figure 3-9 Timing Diagram of SP/SPX9 Read-before-write(Pipeline Read)



Configuration Relationship

Table 3-4 Configuration Relationship of Data Width and Address Depth

Single Port Mode	BSRAM Capacity	Data width	Address Depth
SP	16K	1	14
		2	13
		4	12
		8	11
		16	10

Single Port Mode	BSRAM Capacity	Data width	Address Depth
		32	9
SPX9	18K	9	11
		18	10
		36	9

Port Diagram

Figure 3-10 SP/SPX9 Port Diagram

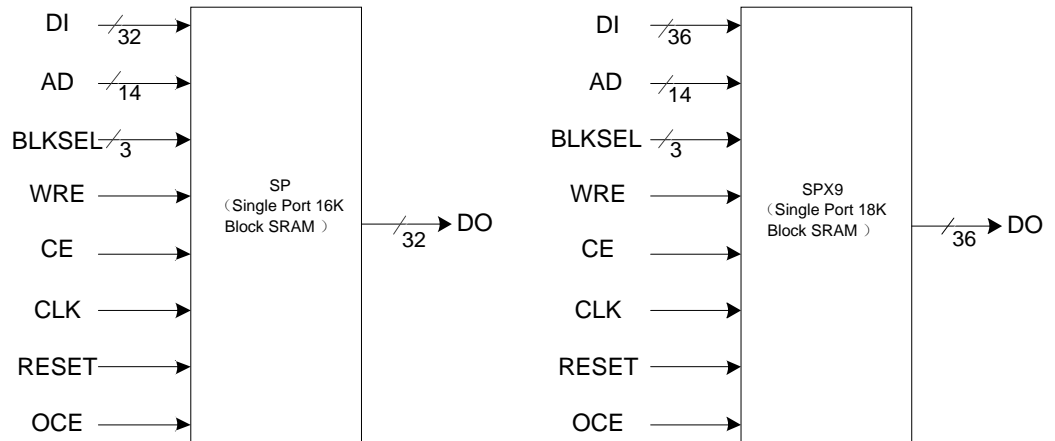

Port Description

Table 3-5 Port Description

Port Name	I/O	Description
DO[31:0]/DO[35:0]	Output	Data output
DI[31:0]/DI[35:0]	Input	Data input
AD[13:0]	Input	Address input
WRE	Input	Write enable input 1: write 0: read
CE	Input	Clock enable input, active-high.
CLK	Input	Clock input
RESET	Input	Reset input, synchronous reset and asynchronous reset supported, active-high
OCE	Input	Output clock enable signal used in Pipeline, invalid in Bypass
BLKSEL[2:0]	Input	BSRAM block selection signal for multiple BSRAM memory units cascading to realize capacity expansion

Parameter

Table 3-6 Parameter Description

Name	Type	Value	Default Value	Description
READ_MODE	Integer	1'b0,1'b1	1'b0	Read mode configuration 1'b0:bypass 1'b1:pipeline
WRITE_MODE	Integer	2'b00,2'b01,2'b10	2'b00	Write mode configuration 2'b00: Normal 2'b01:write-through 2'b10: Read-before-write
BIT_WIDTH	Integer	SP:1,2,4,8,16,32 SPX9:9,18,36	SP:32 SPX9:36	Data width configuration
BLK_SEL	Integer	3'b000~3'b111	3'b000	BSRAM block selection parameter is equal to BLKSEL, and the BSRAM is selected. The software will handle expansion automatically when IP Core Generator is used to expand storage capacity.
RESET_MODE	String	SYNC,ASYNC	SYNC	Reset mode configuration SYNC: synchronized reset ASYNC: asynchronous reset
INIT_RAM_00~ INIT_RAM_3F	Integer	SP:256'h0...0~256'h1...1 SPX9:288'h0...0~288'h1...1	SP:256'h0...0 SPX9:288'h0...0	Used to set up BSRAM memory unit initialization data

Primitive Instantiation

You can instantiate the primitives directly or generate them through IP Core Generator. For details, see chapter [6IP Generation](#). Take SP as an example to introduce the instantiation.

Verilog Instantiation:

```
SP bram_sp_0 (
    .DO({dout[31:8], dout[7:0]}),
    .CLK(clk),
    .OCE(oce),
    .CE(ce),
    .RESET(reset),
    .WRE(wre),
    .BLKSEL({3'b000}),
    .AD({ad[10:0], 3'b000}),
    .DI({{24{1'b0}}, din[7:0]})
```

```

);
defparam bram_sp_0.READ_MODE = 1'b0;
defparam bram_sp_0.WRITE_MODE = 2'b00;
defparam bram_sp_0.BIT_WIDTH = 8;
defparam bram_sp_0.BLK_SEL = 3'b000;
defparam bram_sp_0.RESET_MODE = "SYNC";
defparam bram_sp_0.INIT_RAM_00 =
256'h00A0000000000000B00A000000000000B00A000000000000B00
A0000000000000B;
defparam bram_sp_0.INIT_RAM_01 =
256'h00A0000000000000B00A000000000000B00A000000000000B00
A0000000000000B;
defparam bram_sp_0.INIT_RAM_3F =
256'h00A0000000000000B00A000000000000B00A000000000000B00
A0000000000000B;

```

Vhdl Instantiation:

```

COMPONENT SP
    GENERIC(
        BIT_WIDTH:integer:=32;
        READ_MODE:bit:='0';
        WRITE_MODE:bit_vector:="01";
        BLK_SEL:bit_vector:="000";
        RESET_MODE:string:="SYNC";
        INIT_RAM_00:bit_vector:=X"00A0000000000000B
00A0000000000000B00A0000000000000B00A0000000000000B ";
        INIT_RAM_01:bit_vector:=X"00A0000000000000B
00A0000000000000B00A0000000000000B00A0000000000000B ";
        INIT_RAM_3F:bit_vector:=X"00A0000000000000B
00A0000000000000B00A0000000000000B00A0000000000000B "
    );
    PORT(
        DO:OUT std_logic_vector(31 downto 0):=conv_
std_logic_vector(0,32);
        CLK,CE,OCE,RESET,WRE:IN std_logic;
        AD:IN std_logic_vector(13 downto 0);
        BLKSEL:IN std_logic_vector(2 downto 0);
        DI:IN std_logic_vector(31 downto 0)
    );

```

```

END COMPONENT;
 uut:SP
   GENERIC MAP(
     BIT_WIDTH=>32,
     READ_MODE=>'0',
     WRITE_MODE=>"01",
     BLK_SEL=>"000",
     RESET_MODE=>"SYNC",
     INIT_RAM_00=>X"00A0000000000000B00A00
0000000000B00A00000000000000B00A00000000000000B ",
     INIT_RAM_01=>X"00A0000000000000B00A00
0000000000B00A00000000000000B00A00000000000000B ",
     INIT_RAM_02=>X"00A0000000000000B00A00
0000000000B00A00000000000000B00A00000000000000B ",
     INIT_RAM_3F=>X"00A0000000000000B00A00
0000000000B00A00000000000000B00A00000000000000B "
   )
   PORT MAP (
     DO=>dout,
     CLK=>clk,
     OCE=>oce,
     CE=>ce,
     RESET=>reset,
     WRE=>wre,
     BLKSEL=>blkssel,
     AD=>ad,
     DI=>din
   );

```

3.3 Semi Dual Port Mode

Primitive

SDPB/SDPX9B (Semi Dual Port 16K BSRAM /Semi Dual Port 18K BSRAM).

Functional Description

SDPB/SDPX9B works in semi-dual port mode with its memory space of 16K bit/18K bit. Port A support write operation and port B support read operation^[1]. SDPB/SDPX9B supports two read modes (bypass mode and pipeline mode) and one write mode (normal mode).

Note!

[1] Performing read and write operations to the same address at the same time is not allowed.

- Read Mode

You can configure the output pipeline register by READ_MODE. When the output pipeline register is used, the read operation needs extra delay cycle.

- Write Mode

Port A supports write operation and port B support read operation.

The timing diagram of semi-dual port different read modes is shown in Figure 3-11 and Figure 3-12.

Figure 3-11 Timing Diagram of Semi Dual Port BSRAM Normal Write(Bypass Read)

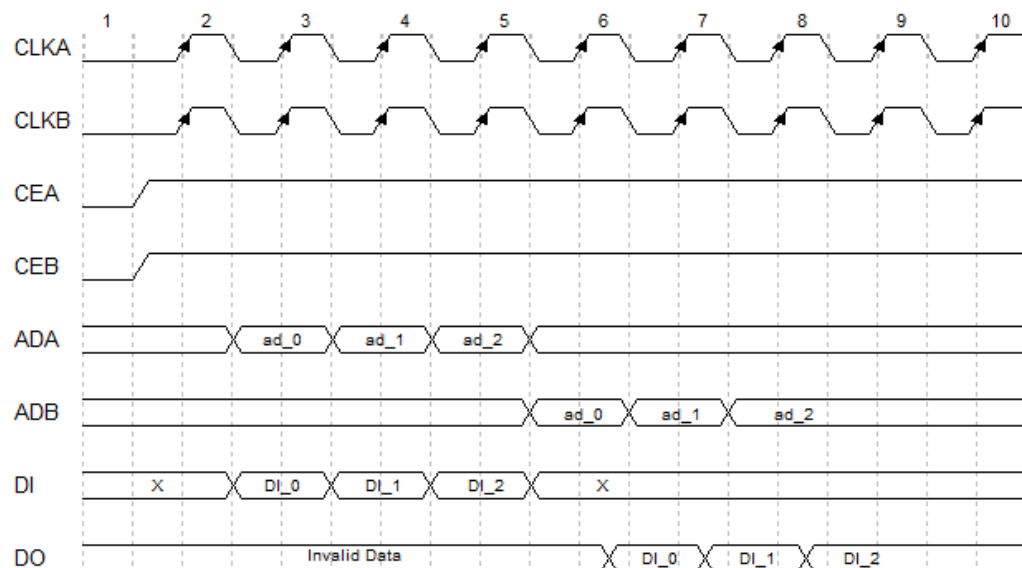
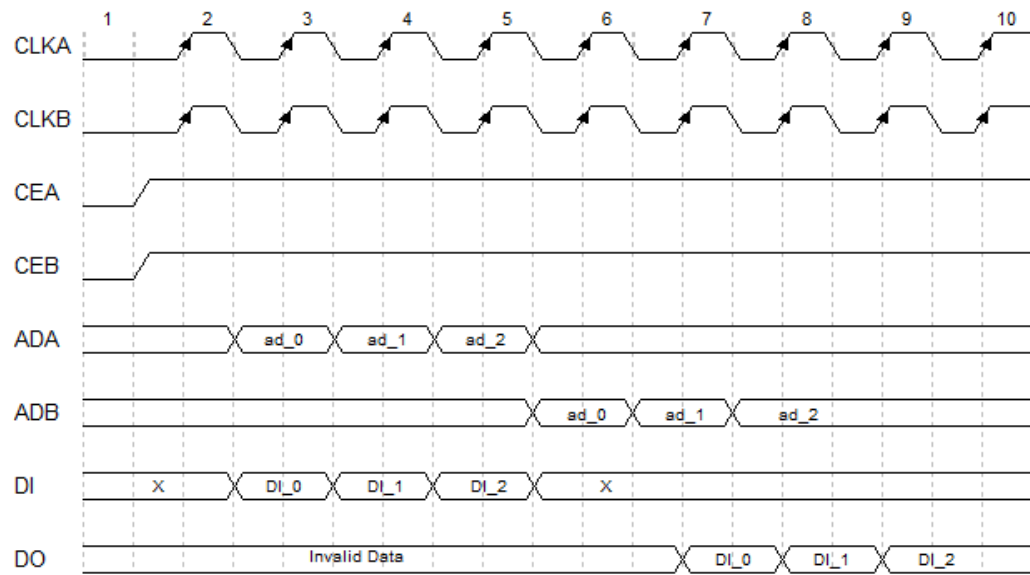

Figure 3-12 Timing Diagram of Semi Dual Port BSRAM Normal Write(Pipeline Read)



Configuration Relationship

Table 3-7 Configuration Relationship of Data Width and Address Depth

Semi-dual Port Mode	BSRAM Capacity	Data Width	Address Depth
SDPB	16K	1	14
		2	13
		4	12
		8	11
		16	10
SDPX9B	18K	9	11
		18	10
		36	9

Port Diagram

Figure 3-13 SDPB/SDPX9B Diagram

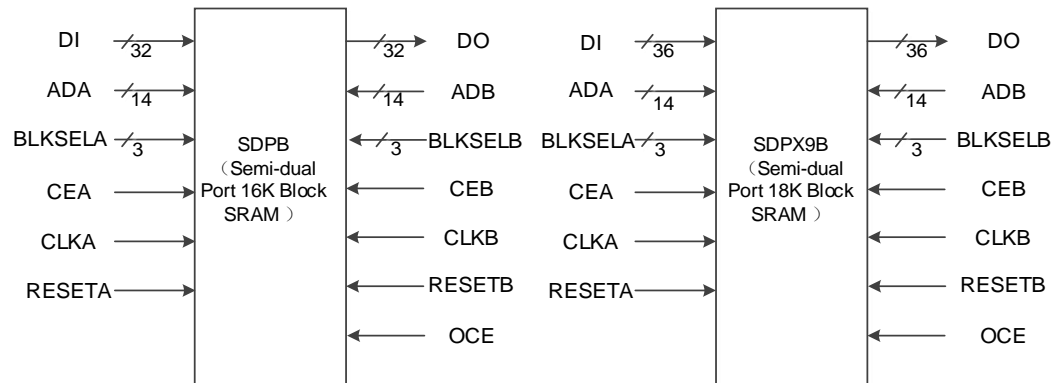

Port Description

Table 3-8 Port Description

Name	I/O	Description
DO[31:0]/DO[35:0]	Output	Data output
DI[31:0]/DI[35:0]	Input	Data input
ADA[13:0]	Input	A address input
ADB[13:0]	Input	B address input
CEA	Input	A clock enable signal, active-high
CEB	Input	B clock enable signal, active-high
CLKA	Input	A clock input
CLKB	Input	B clock input
RESETA	Input	A reset input, synchronous reset and asynchronous reset supported, active-high.
RESETB	Input	B reset input, synchronous reset and asynchronous reset supported, active-high. It is the RESETB reset register, rather than the value of reset register.
OCE	Input	Output clock enable signal used in Pipeline, invalid in Bypass
BLKSELA[2:0]	Input	BSRAM A port block selection signal for multiple BSRAM memory units cascading to realize capacity expansion
BLKSELB[2:0]	Input	BSRAM B port block selection signal for multiple BSRAM memory units cascading to realize capacity expansion

Parameter

Table 3-9 Parameter Description

Name	Type	Range	Default	Description
READ_MODE	Integer	1'b0,1'b1	1'b0	Read mode configuration 1'b0:bypass 1'b1:pipeline

Name	Type	Range	Default	Description
BIT_WIDTH_0	Integer	SDPB:1,2,4,8,16,32 SDPX9B:9,18,36	SDPB:32 SDPX9B:36	A data width configuration
BIT_WIDTH_1	Integer	SDPB:1,2,4,8,16,32 SDPX9B:9,18,36	SDPB:32 SDPX9B:36	B data width configuration
BLK_SEL_0	Integer	3'b000~3'b111	3'b000	When BSRAM A block selection parameter is equal to BLKSEL, the BSRAM is selected. The software will handle expansion automatically when IP Core Generator is used to expand storage capacity.
BLK_SEL_1	Integer	3'b000~3'b111	3'b000	When BSRAM B block selection parameter is equal to BLKSEL, the BSRAM is selected. The software will handle expansion automatically when IP Core Generator is used to expand storage capacity.
RESET_MODE	String	SYNC,ASYNC	SYNC	Reset mode configuration SYNC: synchronous reset ASYNC: asynchronous reset
INIT_RAM_00 ~ INIT_RAM_3F	Integer	SDPB:256'h0...0~256'h1...1 SDPX9B:288'h0...0~288'h1...1	SDPB:256'h0...0 SDPX9B:288'h0...0	Used to set BSRAM initialization data

Primitive Instantiation

You can instantiate the primitives directly or generate them through IP Core Generator. For details, see chapter [6 IP Generation](#). Take SDPB as an example to introduce the instantiation.

Verilog Instantiation:

```
SDPB bram_sdpb_0 (
    .DO({dout[31:16],dout[15:0]}),
```

```

        .CLKA(clka),
        .CEA(cea),
        .RESETA(reseta),
        .CLKB(clkb),
        .CEB(ceb),
        .RESETB(resetb),
        .OCE(oce),
        .BLKSELA({3'b000}),
        .BLKSELB({3'b000}),
        .ADA({ada[9:0], 2'b00, 2'b11}),
        .DI({{16{1'b0}}, din[15:0]}),
        .ADB({adb[9:0], 4'b0000})
    );
    defparam bram_sdpb_0.READ_MODE = 1'b1;
    defparam bram_sdpb_0.BIT_WIDTH_0 = 16;
    defparam bram_sdpb_0.BIT_WIDTH_1 = 16;
    defparam bram_sdpb_0.BLK_SEL_0 = 3'b000;
    defparam bram_sdpb_0.BLK_SEL_1 = 3'b000;
    defparam bram_sdpb_0.RESET_MODE = "SYNC";
    defparam bram_sdpb_0.INIT_RAM_00 =
    256'h00A0000000000000B00A000000000000B00A000000000000B00
    A0000000000000B;
    defparam bram_sdpb_0.INIT_RAM_3F =
    256'h00A0000000000000B00A000000000000B00A000000000000B00
    A0000000000000B;

```

Vhdl Instantiation:

```

COMPONENT SDPB
    GENERIC(
        BIT_WIDTH_0:integer:=16;
        BIT_WIDTH_1:integer:=16;
        READ_MODE:bit:='0';
        BLK_SEL_0:bit_vector:="000";
        BLK_SEL_1:bit_vector:="000";
        RESET_MODE:string:="SYNC";
        INIT_RAM_00:bit_vector:=X"00A0000000000000
    B00A000000000000B00A000000000000B00A000000000000B";

```

```

        INIT_RAM_01:bit_vector:=X"00A0000000000000
B00A00000000000000B00A00000000000000B00A00000000000000B";
        INIT_RAM_3F:bit_vector:=X"00A0000000000000
B00A00000000000000B00A00000000000000B00A00000000000000B"
    );
    PORT(
        DO:OUT std_logic_vector(31 downto 0):=conv_
std_logic_vector(0,32);
        CLKA,CLKB,CEA,CEB:IN std_logic;
        OCE,RESETA,RESETB:IN std_logic;
        ADA,ADB:IN std_logic_vector(13 downto 0);
        BLKSELA:IN std_logic_vector(2 downto 0);
        BLKSELB:IN std_logic_vector(2 downto 0);
        DI:IN std_logic_vector(31 downto 0)
    );
END COMPONENT;
 uut:SDPB
    GENERIC MAP(
        BIT_WIDTH_0=>16,
        BIT_WIDTH_1=>16,
        READ_MODE=>'0',
        BLK_SEL_0=>"000",
        BLK_SEL_1=>"000",
        RESET_MODE=>"SYNC",
        INIT_RAM_00=>X"00A0000000000000B00A00
0000000000B00A00000000000000B00A00000000000000B",
        INIT_RAM_01=>X"00A0000000000000B00A00
0000000000B00A00000000000000B00A00000000000000B",
        INIT_RAM_3F=>X"00A0000000000000B00A00
0000000000B00A00000000000000B00A00000000000000B"
    )
    PORT MAP(
        DO=>dout,
        CLKA=>clka,
        CEA=>cea,
        RESETA=>reseta,
        CLKB=>clkb,

```

```

CEB=>ceb,
RESETB=>resetb,
OCE=>oce,
BLKSELA=>blksele,
BLKSELB=>blkselb,
ADA=>ada,
DI=>din,
ADB=>adb
);

```

3.4 Read-only Mode

Primitive

pROM/pROMX9 (16K Block ROM /18K Block ROM)

Functional Description

ROM/ROMX9 works in read only mode with the memory capacity of 16K bit/18K bit and supports two read modes (bypass mode and pipeline mode).

Enable or disable output pipeline register by READ_MODE. When using the output pipeline register, the read requires an additional delay.

The timing diagram of ROM different read modes is as shown in Figure 3-14 and Figure 3-15.

Figure 3-14 Timing Diagram of ROM(Bypass Read)

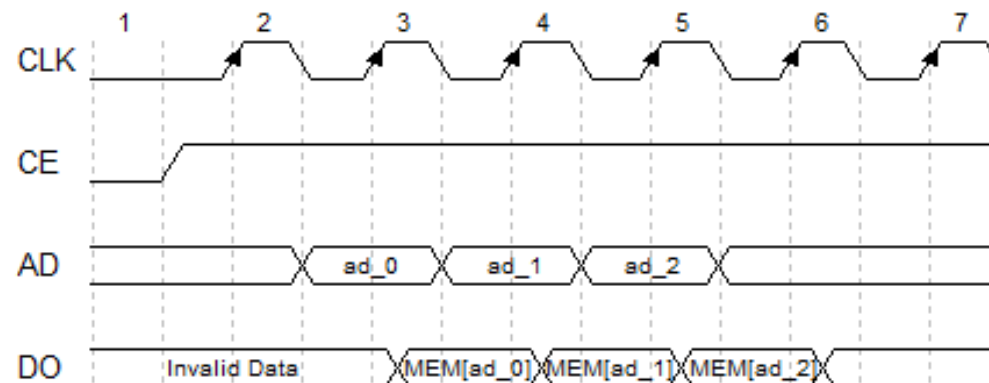
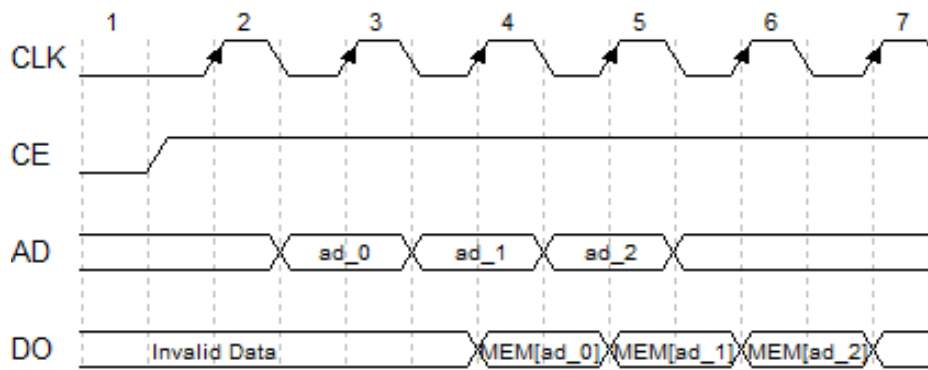

Figure 3-15 Timing Diagram of ROM(Pipeline Read)



Configuration Relationship

Table 3-10 Configuration Relationship of Data Width and Address Depth

Read-only Mode	BSRAM Capacity	Data Width	Address Depth
pROM	16K	1	14
		2	13
		4	12
		8	11
		16	10
		32	9
pROMX9	18K	9	11
		18	10
		36	9

Port Diagram

Figure 3-16 pROM/pROMX9 Diagram

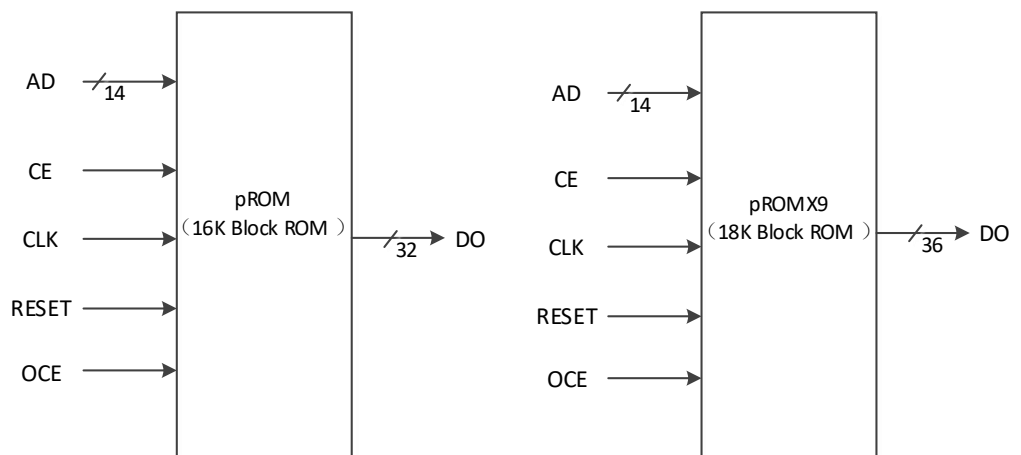

Port Description

Table 3-11 Port Description

Name	I/O	Description
DO[31:0]/DO[35:0]	Output	Data output
AD[13:0]	Input	Address input
CE	Input	Clock enable input, active-high.
CLK	Input	Clock input
RESET	Input	Reset input, supporting synchronous and asynchronous reset, active-high. It is the RESET reset register, rather than the value of reset register.
OCE	Input	Output clock enable signal used for Pipeline, invalid in Bypass.

Parameter

Table 3-12 Parameter Description

Name	Type	Range	Default	Description
READ_MODE	Integer	1'b0,1'b1	1'b0	Read mode configuration 1'b0:bypass 1'b1:pipeline
BIT_WIDTH	Integer	pROM:1,2,4,8,16,32 pROMX9:9,18,36	pROM:32 pROMX9:36	Data width configuration
RESET_MODE	String	SYNC,ASYNC	SYNC	Reset mode configuration SYNC: synchronous reset ASYNC: asynchronous reset
INIT_RAM_00~ INIT_RAM_3F	Integer	pROM:256'h0...0~256'h1...1 pROMX9:288'h0...0~288'h1...1	pROM:256'h0...0 pROMX9:288'h0...0	Used to set BSRAM initialization data

Primitive Instantiation

You can instantiate the primitives directly or generate them through IP Core Generator. For details, see chapter [6IP Generation](#). Take pROM as an example to introduce the instantiation.

Verilog Instantiation:

```
pROM bram_prom_0 (
```

4 BSRAM Output Reset

RESET signal acts on the output module and the module outputs reset data 0. The diagram is shown in Figure 4-1.

Figure 4-1 Reset Diagram

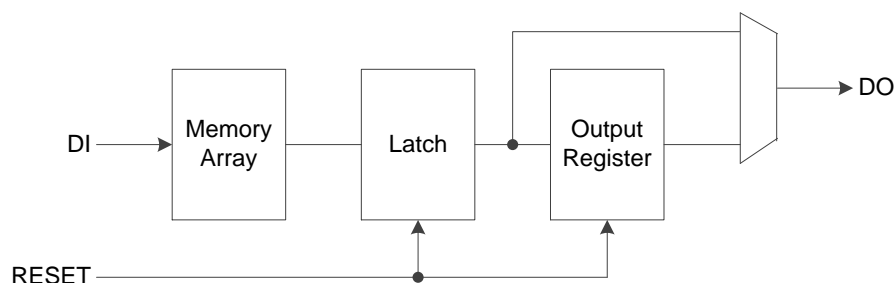

When the RESET signal is high-level, the output port outputs 0.

RESET supports synchronous and asynchronous reset, which is set by RESET_MODE when you call the primitives library. When you use IP Core Generator, the reset mode can be selected through GUI. For the details, see chapter 6 IP Generation.

RESET signal resets the latch and the output register. When RESET signal is valid, the port outputs 0 whether you use the register output mode or the bypass output mode.

Note!

RESET signal must be set to 0 (invalid) during write operation.

The timing diagrams of synchronous and asynchronous reset modes are as shown from Figure 4-2 to Figure 4-5. DO_RAM represents the data in the storage array, and DO represents the data of the output port.

The register output mode is as follows.

- When synchronous reset is valid, DO is reset to 0 at CLK pos-edge.
- When asynchronous reset is valid, DO is reset to 0 without waiting for CLK pos-edge.
- When reset is invalid but OCE signal is valid, DO outputs DO_RAM.
- When reset and OCE signal are both invalid, DO retains the last

output.

The bypass output mode is as follows:

- When synchronous reset is valid, DO is reset to 0 at CLK pos-edge.
- When asynchronous reset is valid, DO is reset to 0 without waiting for CLK pos-edge.
- When reset is invalid, DO outputs DO_RAM whether OCE signal is valid.

Figure 4-2 Timing Diagram of Synchronous Reset(Pipeline)

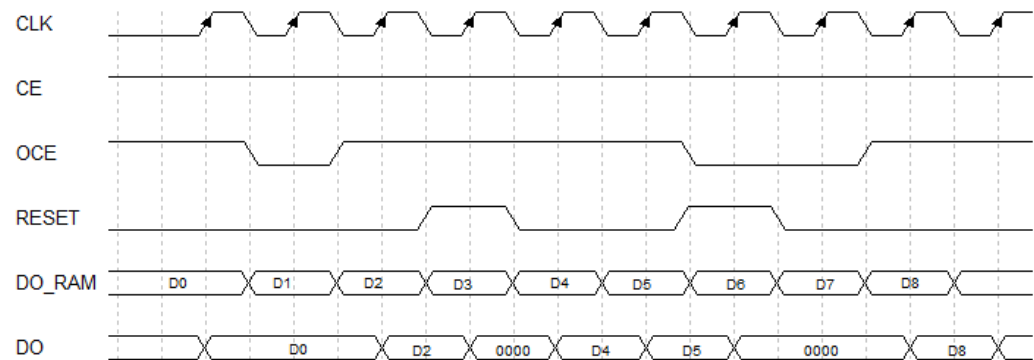

Figure 4-3 Timing Diagram of Synchronous Reset(Bypass)

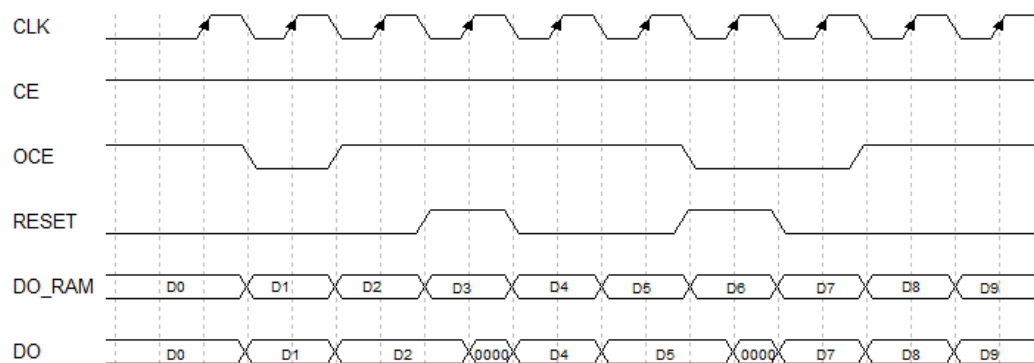

Figure 4-4 Timing Diagram of Asynchronous Reset(Pipeline)

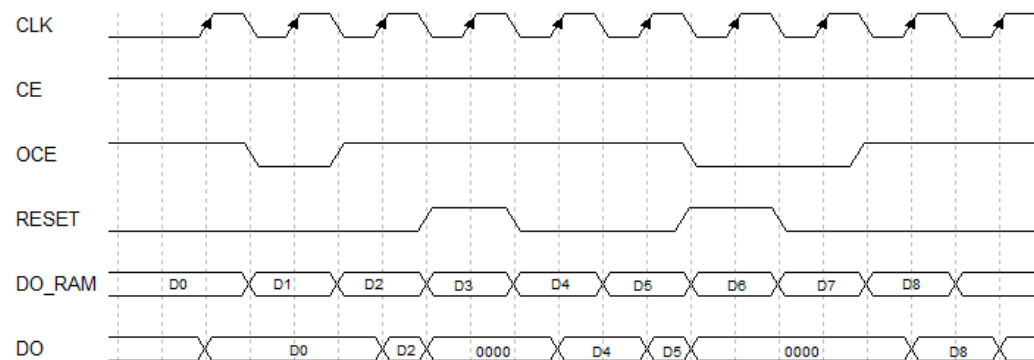
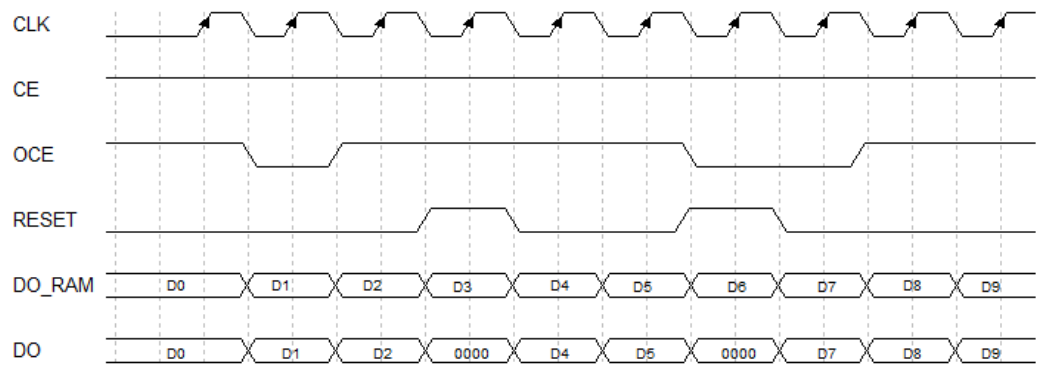

Figure 4-5 Timing Diagram of Asynchronous Reset(Bypass)



5 SSRAM Primitives

The Shadow Memory can be configured as single port mode, semi-dual port mode and read-only mode, as shown in Table 5-1.

Table 5-1 Shadow Memory Mode

Primitive	Description
RAM16S1	Single port SSRAM with address depth 16 and data width 1
RAM16S2	Single port SSRAM with address depth 16 and data width 2
RAM16S4	Single port SSRAM with address depth 16 and data width 4
RAM16SDP1	Semi-dual port SSRAM with address depth 16 and data width 1
RAM16SDP2	Semi-dual port SSRAM with address depth 16 and data width 2
RAM16SDP4	Semi-dual port SSRAM with address depth 16 and data width 4
ROM16	Read-only ROM with address depth 16 and data width 1

Note!

- GW1N-1, GW1N-1S, GW1N-4, GW1N-4B, GW1NR-1, GW1NR-4, GW1NR-4B, GW1NRF-4B, GW1NS-4, GW1NS-4C, GW1NSER-4C, GW1NSR-4, GW1NSR-4C, GW1N-4D and GW1NR-4D devices do not support SSRAM.
- For the GW2A(R)-18 and GW2A(N)-55 devices, only the C version supports reading the initial values of the SSRAM.

5.1 RAM16S1

Primitive

16-Deep by 1-Wide Single-port SSRAM (RAM16S1) is a single-port SSRAM with address depth of 16 and bit width of 1.

Functional Description

RAM16S1 is a single-port SSRAM with bit width of 1. The read and write addresses are the same. When WRE is high, you can perform write operation. At this time, the data is loaded to the address corresponding to memory at the pos-edge of CLK. The address determines the read data in RAM in read operation. That is, SSRAM is implemented by the LUT of CFU, synchronous write and asynchronous read. However, if required, a

register associated with each LUT can be used for synchronous read. The timing diagram is shown in Figure 5-1.

Figure 5-1 Timing Diagram of RAM16S1

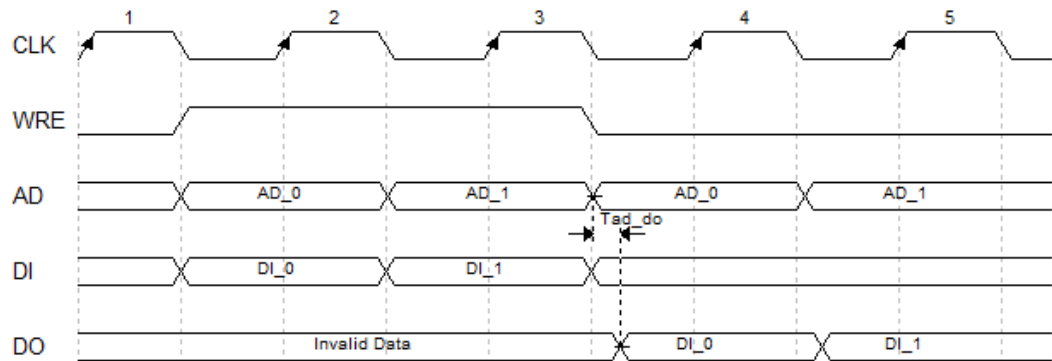

Port Diagram

Figure 5-2 RAM16S1Blcok Diagram

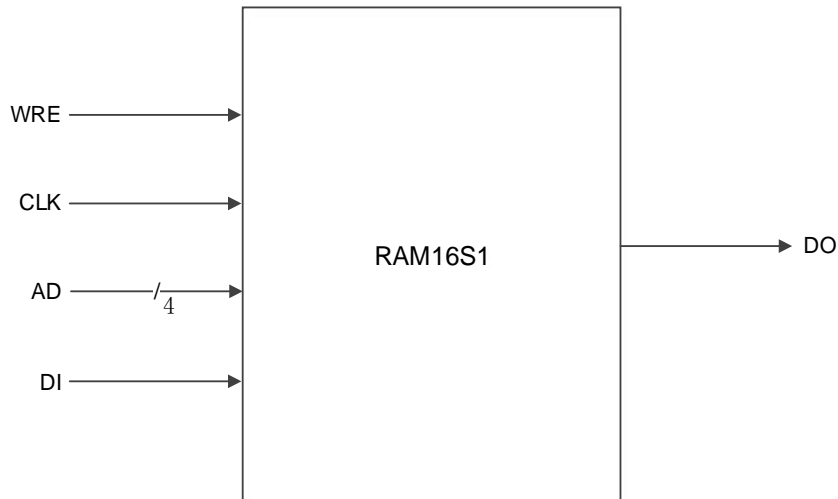

Port Description

Table 5-2 Port Description

Port Name	I/O	Description
DI	Input	Data Input
CLK	Input	Clock input
WRE	Input	Write Enable Input
AD[3:0]	Input	Address Input
DO	Output	Data Output

Parameter

Table 5-3 Parameter Description

Name	Value	Default	Description
INIT_0	16'h0000~16'hffff	16'h0000	Initial value of the RAM16S1

Primitive Instantiation

You can instantiate the primitives directly or generate them through IP Core Generator. For details, see chapter [6 IP Generation](#).

Verilog Instantiation:

```
RAM16S1 instName(
    .DI(DI),
    .WRE(WRE),
    .CLK(CLK),
    .AD(AD[3:0]),
    .DO(DOUT)
);
defparam instName.INIT_0=16'h1100;
```

Vhdl Instantiation:

```
COMPONENT RAM16S1
    GENERIC (INIT:bit_vector:=X"0000");
    PORT(
        DO:OUT std_logic;
        DI:IN std_logic;
        CLK:IN std_logic;
        WRE:IN std_logic;
        AD:IN std_logic_vector(3 downto 0)
    );
END COMPONENT;
 uut:RAM16S1
    GENERIC MAP(INIT=>X"0000")
    PORT MAP (
        DO=>DOUT,
        DI=>DI,
        CLK=>CLK,
        WRE=>WRE,
```

```
AD=>AD
```

```
);
```

5.2 RAM16S2

Primitive

16-Deep by 2-Wide Single-port SSRAM (RAM16S2) is a single-port SSRAM with address depth of 16 and bit width of 2.

Functional Description

RAM16S2 is a single-port SSRAM with bit width of 2. The read and write addresses are the same. When WRE is high, you can perform write operation. At this time, the data is loaded to the address corresponding to memory at the pos-edge of CLK. The address determines the read data in RAM in read operation. That is, SSRAM is implemented by the LUT of CFU, synchronous write and asynchronous read. However, if required, a register associated with each LUT can be used for synchronous read. The timing diagram is shown in Figure 5-1.

Port Diagram

Figure 5-3 RAM16S2 Port Diagram

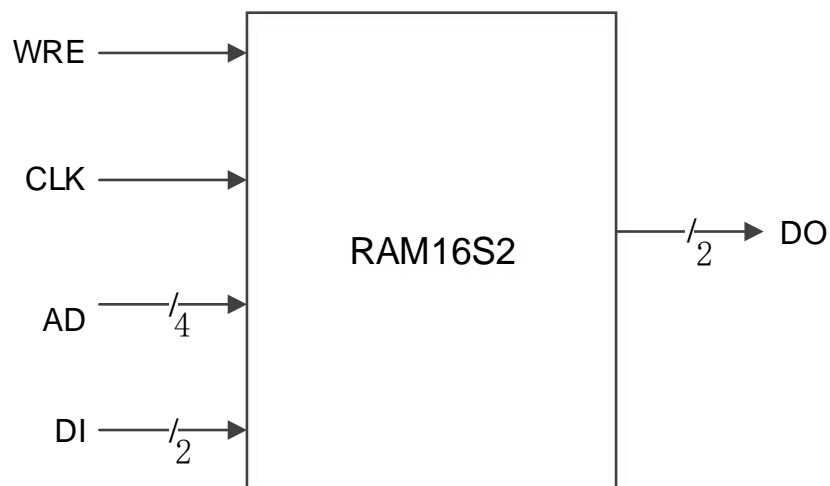

Port Description

Table 5-4 Port Description

Port Name	I/O	Description
DI[1:0]	Input	Data Input
CLK	Input	Clock input
WRE	Input	Write Enable Input
AD[3:0]	Input	Address Input
DO[1:0]	Output	Data Output

Parameter

Table 5-5 Parameter Description

Name	AllowedValues	Default	Description
INIT_0~ INIT_1	16'h0000~16'hfff f	16'h0000	Initial value of the RAM16S2

Primitive Instantiation

You can instantiate the primitives directly or generate them through IP Core Generator. For details, see chapter [6IP Generation](#).

Verilog Instantiation:

```
RAM16S2 instName(
    .DI(DI[1:0]),
    .WRE(WRE),
    .CLK(CLK),
    .AD(AD[3:0]),
    .DO(DOUT[1:0])
);
defparam instName.INIT_0=16'h0790;
defparam instName.INIT_1=16'h0f00;
```

Vhdl Instantiation:

```
COMPONENT RAM16S2
    GENERIC (INIT_0:bit_vector:=X"0000";
            INIT_1:bit_vector:=X"0000"
    );
    PORT(
        DO:OUT std_logic_vector(1 downto 0);
        DI:IN std_logic_vector(1 downto 0);
        CLK:IN std_logic;
        WRE:IN std_logic;
        AD:IN std_logic_vector(3 downto 0)
    );
END COMPONENT;
uut:RAM16S2
    GENERIC MAP(INIT_0=>X"0000",
                INIT_1=>X"0000"
    )
    PORT MAP (
```

```

        DO=>DOUT,
        DI=>DI,
        CLK=>CLK,
        WRE=>WRE,
        AD=>AD
    );

```

5.2.1 RAM16S4

Primitive

16-Deep by 4-Wide Single-port SSRAM (RAM16S4) is a single-port SSRAM with address depth of 16 and bit width of 4.

Functional Description

RAM16S4 is a single-port SSRAM with bit width of 4. The read and write addresses are the same. When WRE is high, you can perform write operation. At this time, the data is loaded to the address corresponding to memory at the pos-edge of CLK. The address determines the read data in RAM in read operation. That is, SSRAM is implemented by the LUT of CFU, synchronous write and asynchronous read. However, if required, a register associated with each LUT can be used for synchronous read. The timing diagram is shown in Figure 5-1.

Diagram

Figure 5-4 RAM16S4 Diagram

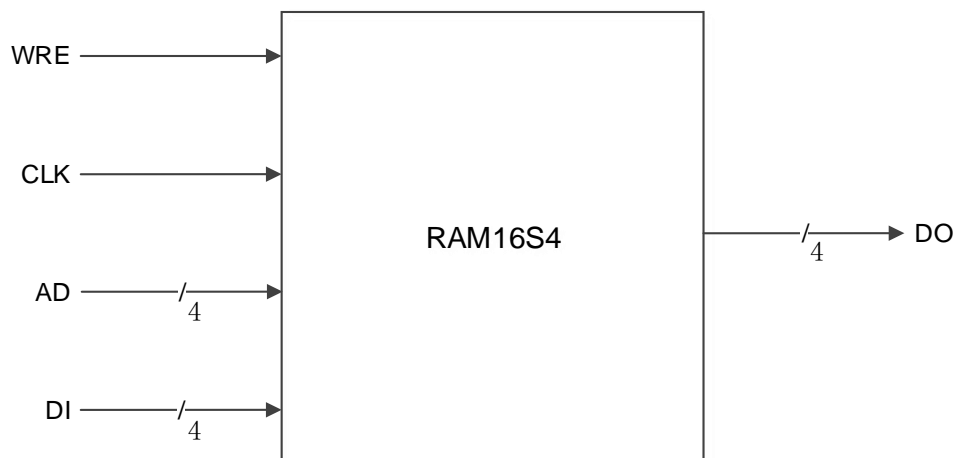

Port Description

Table 5-6 Port Description

Port Name	I/O	Description
DI[3:0]	Input	Data Input
CLK	Input	Clock input
WRE	Input	Write Enable Input
AD[3:0]	Input	Address Input
DO[3:0]	Output	Data Output

Parameter

Table 5-7 Parameter Description

Name	Value	Default	Description
INIT_0~ INIT_3	16'h0000~16'hfff f	16'h0000	Initial value of the RAM16S4

Primitive Instantiation

You can instantiate the primitives directly or generate them through IP Core Generator. For details, see chapter [6IP Generation](#).

Verilog Instantiation:

```
RAM16S4 instName(
    .DI(DI[3:0]),
    .WRE(WRE),
    .CLK(CLK),
    .AD(AD[3:0]),
    .DO(DOUT[3:0])
);
defparam instName.INIT_0=16'h0450;
defparam instName.INIT_1=16'h1ac3;
defparam instName.INIT_2=16'h1240;
defparam instName.INIT_3=16'h045c;
```

Vhdl Instantiation:

```
COMPONENT RAM16S4
    GENERIC (INIT_0:bit_vector:=X"0000";
            INIT_1:bit_vector:=X"0000";
            INIT_2:bit_vector:=X"0000";
            INIT_3:bit_vector:=X"0000"
    );
```

```

        PORT(
            DO:OUT std_logic_vector(3 downto 0);
            DI:IN std_logic_vector(3 downto 0);
            CLK:IN std_logic;
            WRE:IN std_logic;
            AD:IN std_logic_vector(3 downto 0)
        );
    END COMPONENT;
    uut:RAM16S4
        GENERIC MAP(INIT_0=>"X"0000",
                    INIT_1=>"X"0000",
                    INIT_2=>"X"0000",
                    INIT_3=>"X"0000"
        )
        PORT MAP (
            DO=>DOUT,
            DI=>DI,
            CLK=>CLK,
            WRE=>WRE,
            AD=>AD
        );

```

5.3 RAM16SDP1

Primitive

16-Deep by 1-Wide Semi Dual-port SSRAM (RAM16SDP1) is a semi-dual-port SSRAM with address depth of 16 and bit width of 1.

Functional Description

RAM16SDP1 is a semi-dual-port SSRAM with bit width of 1. The read address is RAD and the write address is WAD, and they are asynchronous. When WRE is high, you can perform write operation. At this time, the data is loaded to the address corresponding to memory at the pos-edge of CLK. The address determines the read data in RAM in read operation. The timing diagram is shown in Figure 5-5.

Figure 5-5 Timing Diagram of RAM16SDP1

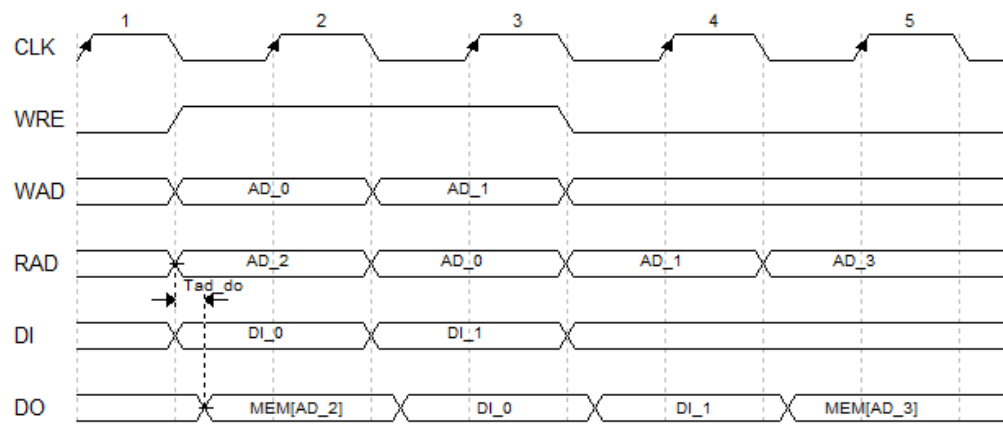

Port Diagram

Figure 5-6 RAMSDP1 Port Diagram

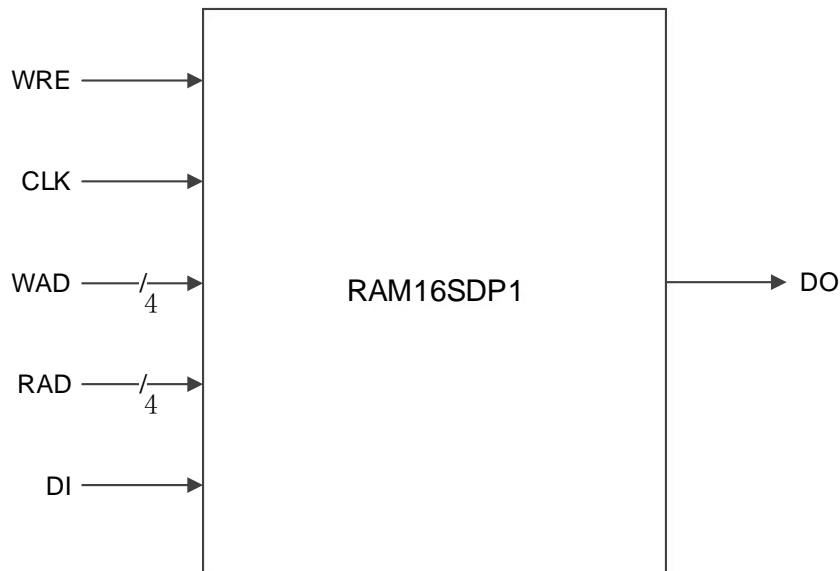

Port Description

Table 5-8 Port Description

Port Name	I/O	Description
DI	Input	Data Input
CLK	Input	Clock input
WRE	Input	Write Enable Input
WAD[3:0]	Input	Write Address
RAD[3:0]	Input	Read Address
DO	Output	Data Output

Parameter

Table 5-9 Parameter Description

Name	Value	Default	Description
INIT_0	16'h0000~16'hffff	16'h0000	Initial value of the RAM16SDP1

Primitive Instantiation

You can instantiate the primitives directly or generate them through IP Core Generator. For details, see chapter [6 IP Generation](#).

Verilog Instantiation:

```
RAM16SDP1 instName(
    .DI(DI),
    .WRE(WRE),
    .CLK(CLK),
    .WAD(WAD[3:0]),
    .RAD(RAD[3:0]),
    .DO(DOUT)
);
defparam instName.INIT_0=16'h0100;
```

Vhdl Instantiation:

```
COMPONENT RAM16SDP1
    GENERIC (INIT_0:bit_vector:=X"0000");
    PORT(
        DO:OUT std_logic;
        DI:IN std_logic;
        CLK:IN std_logic;
        WRE:IN std_logic;
        WAD:IN std_logic_vector(3 downto 0);
        RAD:IN std_logic_vector(3 downto 0)
    );
END COMPONENT;
uut:RAM16SDP1
    GENERIC MAP(INIT_0=>X"0000")
    PORT MAP (
        DO=>DOUT,
        DI=>DI,
```

```

        CLK=>CLK,
        WRE=>WRE,
        WAD=>WAD,
        RAD=>RAD
    );

```

5.4 RAM16SDP2

Primitive

16-Deep by 2-Wide Semi Dual-port SSRAM (RAM16SDP2) is a semi-dual-port SSRAM with address depth of 16 and bit width of 2.

Functional Description

RAM16SDP2 is a semi-dual-port SSRAM with bit width of 2. The read address is RAD and the write address is WAD, and they are asynchronous. When WRE is high, you can perform write operation. At this time, the data is loaded to the address corresponding to memory at the pos-edge of CLK. The address determines the read data in RAM in read operation. The timing diagram is shown in Figure 5-5.

Port Diagram

Figure 5-7 RAM16SDP2 Port Diagram

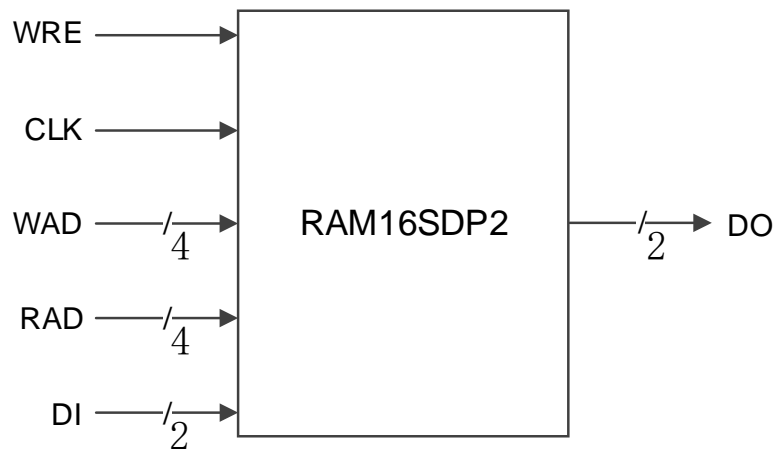

Port Description

Table 5-10 Port Description

Port Name	I/O	Description
DI[1:0]	Input	Data Input
CLK	Input	Clock input
WRE	Input	Write Enable Input
WAD[3:0]	Input	Write Address
RAD[3:0]	Input	Read Address
DO[1:0]	Output	Data Output

Parameter

Table 5-11 Parameter Description

Name	Value	Default	Description
INIT_0~ INIT_1	16'h0000~16'hfff f	16'h0000	Initial value of the RAM16SDP2

Primitive Instantiation

You can instantiate the primitives directly or generate them through IP Core Generator. For details, see chapter [6IP Generation](#).

Verilog Instantiation:

```
RAM16SDP2 instName(
    .DI(DI[1:0]),
    .WRE(WRE),
    .CLK(CLK),
    .WAD(WAD[3:0]),
    .RAD(RAD[3:0]),
    .DO(DOOUT[1:0])
);
defparam instName.INIT_0=16'h5600;
defparam instName.INIT_1=16'h0af0;
```

Vhdl Instantiation:

```
COMPONENT RAM16SDP2
    GENERIC (INIT_0:bit_vector:=X"0000";
            INIT_1:bit_vector:=X"0000"
    );
    PORT(
        DO:OUT std_logic_vector(1 downto 0);
        DI:IN std_logic_vector(1 downto 0);
        CLK:IN std_logic;
        WRE:IN std_logic;
        WAD:IN std_logic_vector(3 downto 0);
        RAD:IN std_logic_vector(3 downto 0)
    );
END COMPONENT;
uut:RAM16SDP2
    GENERIC MAP(INIT_0=>X"0000",
```

```
                INIT_1=>X"0000"  
            )  
    PORT MAP (  
        DO=>DOUT,  
        DI=>DI,  
        CLK=>CLK,  
        WRE=>WRE,  
        WAD=>WAD,  
        RAD=>RAD  
    );
```

5.5 RAM16SDP4

Primitive

16-Deep by 4-Wide Semi Dual-port SSRAM (RAM16SDP4) is a semi-dual-port SSRAM with address depth of 16 and bit width of 4.

Functional Description

RAM16SDP4 is a semi-dual-port SSRAM with bit width of 4. The read address is RAD and the write address is WAD, and they are asynchronous. When WRE is high, you can perform write operation. At this time, the data is loaded to the address corresponding to memory at the pos-edge of CLK. The address determines the read data in RAM in read operation. The timing diagram is shown in Figure 5-5.

Diagram

Figure 5-8 RAMSDP4 Diagram

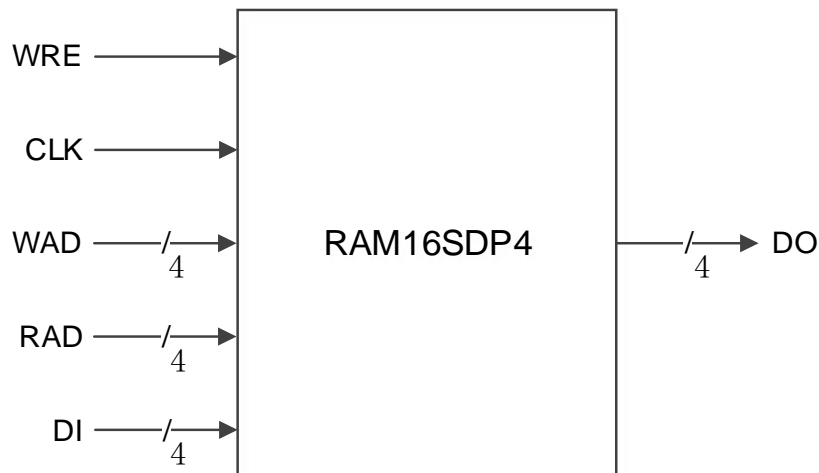

Port Description

Table 5-12 Port Description

Port Name	I/O	Description
DI[3:0]	Input	Data Input
CLK	Input	Clock Input
WRE	Input	Write Enable Input
WAD[3:0]	Input	Write Address
RAD[3:0]	Input	Read Address
DO[3:0]	Output	Data Output

Parameter

Table 5-13 Parameter Description

Name	Value	Default	Description
INIT_0~ INIT_3	16'h0000~16'hffff	16'h0000	Initial value of of the RAM16SDP4

Primitive Instantiation

You can instantiate the primitives directly or generate them through IP Core Generator. For details, see chapter [6IP Generation](#).

Verilog Instantiation:

```
RAM16SDP4 instName(
    .DI(DI[3:0]),
    .WRE(WRE),
    .CLK(CLK),
    .WAD(WAD[3:0]),
    .RAD(RAD[3:0]),
    .DO(DOUT[3:0])
);
defparam instName.INIT_0=16'h0340;
defparam instName.INIT_1=16'h9065;
defparam instName.INIT_2=16'hac12;
defparam instName.INIT_3=16'h034c;
```

Vhdl Instantiation:

```
COMPONENT RAM16SDP2
    GENERIC (INIT_0:bit_vector:=X"0000";
            INIT_1:bit_vector:=X"0000";
            INIT_2:bit_vector:=X"0000";
            INIT_3:bit_vector:=X"0000";
    );
    PORT(
        DO:OUT std_logic_vector(3 downto 0);
        DI:IN std_logic_vector(3 downto 0);
        CLK:IN std_logic;
        WRE:IN std_logic;
        WAD:IN std_logic_vector(3 downto 0);
        RAD:IN std_logic_vector(3 downto 0)
    );
```

```

END COMPONENT;
 uut:RAM16SDP2
     GENERIC MAP(INIT_0=>"X"0000",
                 INIT_1=>"X"0000",
                 INIT_2=>"X"0000",
                 INIT_3=>"X"0000"
                )
     PORT MAP (
         DO=>DOUT,
         DI=>DI,
         CLK=>CLK,
         WRE=>WRE,
         WAD=>WAD,
         RAD=>RAD
     );

```

5.6 ROM16

Primitive

ROM16 is a read-only memory with address depth 16 and data width 1. The memory is initialized using INIT.

Functional Description

ROM16 is a read-only memory with a data bit width of 1, and the address determines the output data in ROM. The timing diagram is shown in Figure 5-9.

Figure 5-9 Timing Diagram of ROM16

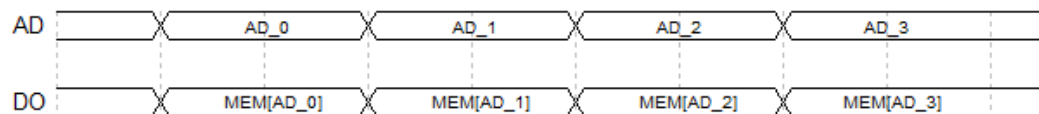

Port Diagram

Figure 5-10 ROM16 Port Diagram

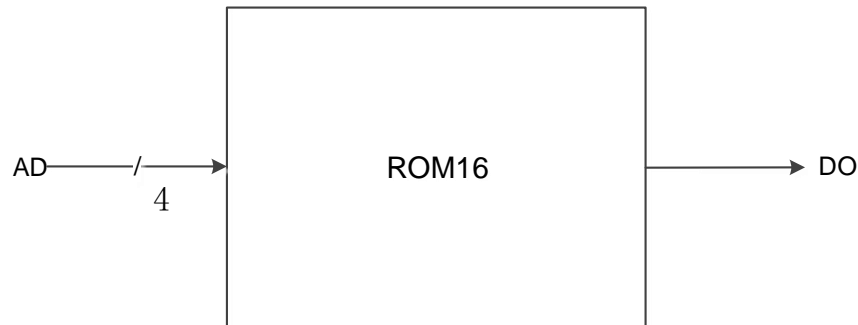

Port Description

Table 5-14 Port Description

Port Name	I/O	Description
AD[3:0]	Input	Address Input
DO	Output	Data Output

Parameter

Table 5-15 Parameter Description

Name	Value	Default	Description
INIT_0	16'h0000~16'hfff	16'h0000	Initial value of the ROM16

Primitive Instantiation

You can instantiate the primitives directly or generate them through IP Core Generator. For details, see chapter [6IP Generation](#).

Verilog Instantiation:

```
ROM16 instName (
    .AD(AD[3:0]),
    .DO(DOUT)
);
defparam instName.INIT_0=16'hfc00;
```

Vhdl Instantiation:

```
COMPONENT ROM16
    GENERIC (INIT:bit_vector:=X"0000");
    PORT(
        DO:OUT std_logic;
        AD:IN std_logic_vector(3 downto 0)
```

```
);  
END COMPONENT;  
uut:ROM16  
  GENERIC MAP(INIT=>X"0000")  
  PORT MAP (  
    DO=>DOUT,  
    AD=>AD  
  );
```

6 IP Generation

You can configure data width, address depth, write mode and read mode of IP Core in Gowin software, and Gowin software generates the corresponding IP module. In addition, there are two ways to implement BSRAM and SSRAM. You can configure ports and parameters to generate the required IP module by invoking Gowin software library files. You can also select synthesis tool to automatically generate BSRAM and SSRAM modes.

In IP Core Generator, the BSRAM module can implement single-port mode, semi-dual-port mode, dual-port mode and read-only mode. The SSRAM module can implement single-port mode, semi-dual-port mode and read-only mode. The following takes BSRAM dual-port mode and SSRAM single-port mode to introduce IP invoking.

6.1 BSRAM Dual-port Mode

DP is the dual port mode of BSRAM, which can be implemented by DPB and DPX9B primitives. Click "DPB" on the IP Core Generator interface. A brief introduction to the DPB^[1] will be displayed on the right of the screen.

Note!

- ^[1] For C version GW2A(N)(R) devices, when configuring the BSRAM to 1/2/4/8/9-bit width, "Revised DP" is used ("Revised SP" is used in single-port mode).

IP Configuration

Double click the "DPB" to open the "IP Customization" window. This includes the "General" configuration, "Options" configuration, and ports diagram, as shown in Figure 6-1.

Figure 6-1 IP Customization of DPB

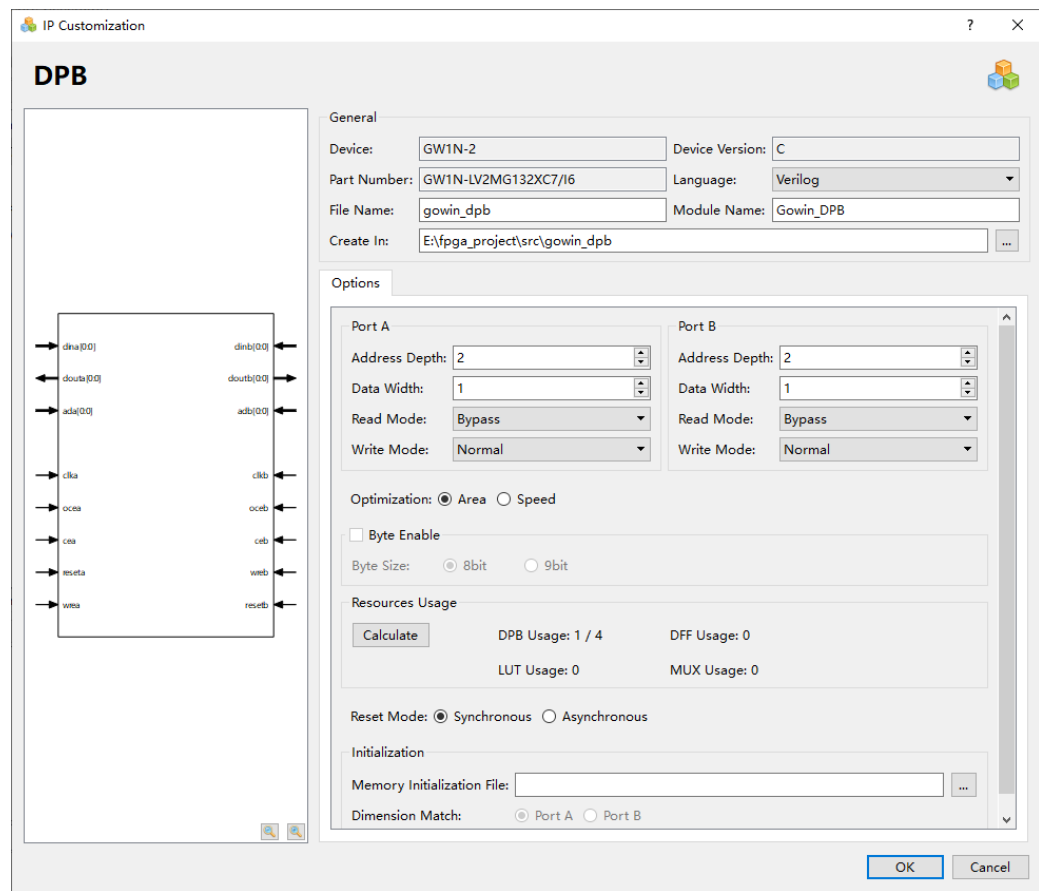

1. The General configuration box includes the basic information related to IP design file, as shown in Figure 6-1.
 - Device: Select a device
 - Device Version: Select a device version
 - Part Number: Select a part number
 - Language: Verilog and VHDL
 - Module Name: The module name of the generated IP Core files. Enter the module name in the text box on the right side. Module name cannot be the same as the primitive Name. If it is the same, an error will be reported;
 - File Name: The name of the generated IP Core files. Enter the file name in the text box on the right side;
 - Create In: The path in which the generated IP files will be stored; Enter the target path in the box on the right side or select the target path by clicking the option button.
2. The Options configuration box is as shown in Figure 6-1.
 - Width & Depth: Configure address depth and data width. If the configuration cannot be implemented by one module, multiple modules will be used to implement the configuration;
 - Resource Usage: Calculate and display the resource usage of Block

Ram, DFF, LUT, and MUX;

- Read/Write Mode: Configure Read/Write modes. DPB supports the following modes;
 - Two Read modes: Bypass and Pipeline;
 - Two Write modes: Normal and Write-Through
- Reset Mode: synchronous or asynchronous;
- Initialization: Allows you to select a memory initialization file for the module. INIT value is written in the initialization file in Binary, Hex or Hex with address. The Memory Initialization File can be written or generated by the menus "File > New > Memory File". For details, please refer to [SUG100, Gowin Software User Guide](#).

Note!

- The address depth, data width and read/write mode of the Port A and Port B of the DPB can be configured independently.
- Port A and Port B of DPB are read and written to the same memory, so Address Depth*Data Width of Port A and Port B must be the same.
- The data width in the initialization file (Memory initialization File) should match the port data width selected by Dimension Match.
- If the address depth and data width of DP Port A and Port B are different, an error message will pop up.
- If the data width is different, the Init value of the generated DPB instantiation is 0 by default, and an error message will be displayed: Error (MG2105): Initial values' width is unequal to user's width.

3. Ports Diagram

- The ports configuration diagram displays the IP Core configuration. Input/Output bit-width updates in real time based on the "Options" configuration, as shown in Figure 6-2.
- "Address Depth" of Port A and Port B affects the bit-width of address; "Data Width" affects the bit-width of input and output.

IP Generation Files

After configuration, click "OK" to generate three files that are named after the "File Name":

- "gowin_dpb.v" file is a complete Verilog module to generate instance RAM16S, and it is generated according to the IP configuration;
- "gowin_dpb_tmp.v" is the instance template file;
- "gowin_dpb.ipc" file is IP configuration file. You can load the file to configure the IP.

Note!

If VHDL is selected as the hardware description language, the first two files will be named with an .vhd suffix. Taking verilog for instance, the following sections introduce the generated files.

6.2 SSRAM Single-port Mode

RAM16S is SSRAM single-port mode, which can be implemented by

RAM16S1, RAM16S2 and RAM16S4 primitives. Click "RAM16S" on the IP Core Generator, and a brief introduction to the RAM16S will be displayed.

IP Configuration

Double-click "RAM16", and the "IP Customization" window pops up. This includes the "File", "Options", and ports diagram, as shown in Figure 6-2.

Figure 6-2 IP Customization of RAM16S

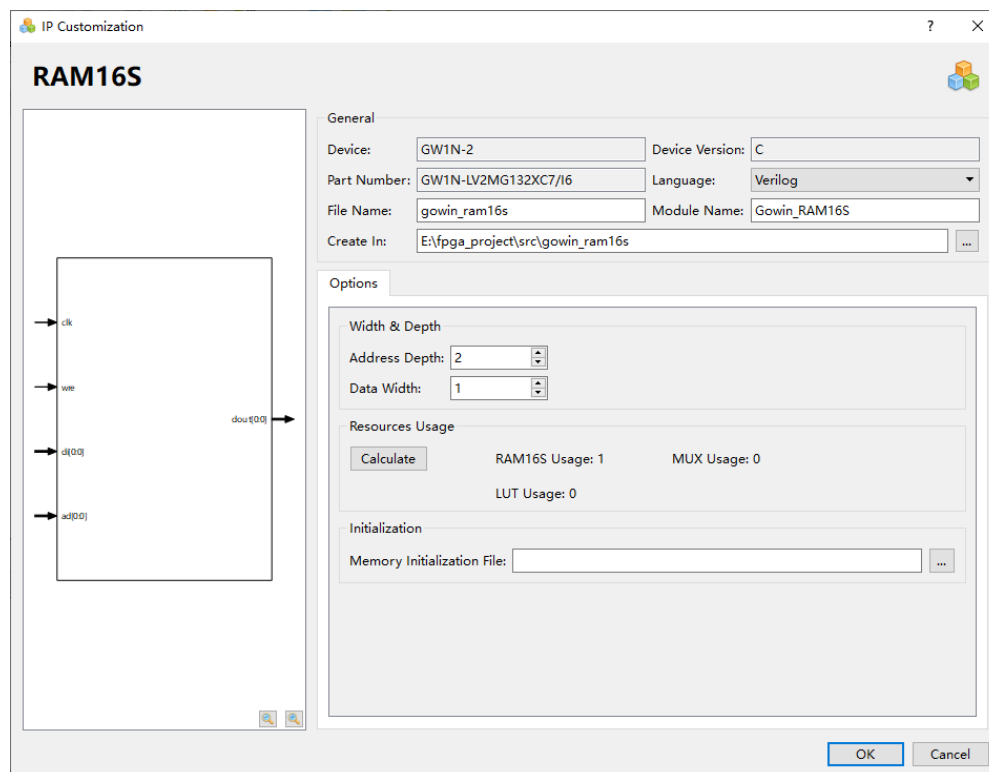

1. The General configuration box is used to configure IP design file. The File configuration box of the RAM16S is similar to the BSRAM dual-port mode. For details, refer to the General configuration box of [6.1 BSRAM Dual-port Mode](#).
2. The Options configuration box is as shown in Figure 6-2. The Options configuration box of the RAM16S is similar to the BSRAM dual-port mode. For details, refer to the Options configuration box of [6.1 BSRAM Dual-port Mode](#).
3. Ports Diagram
 - The ports diagram is based on the IP Core configuration. The input/output bit-width updates in real time based on the "Options" configuration.
 - "Address Depth" affects the bit-width of Address; "Data Width" affects the bit-width of input and output.

IP Generation Files

After configuration, it will generate three files that are named after the "File Name".

- "gowin_ram16s.v" file is a complete Verilog module to generate instance RAM16S, and it is generated according to the IP configuration;
- "gowin_ram16s_tmp.v" is the instance template file;
- "gowin_ram16s.ipc" file is IP configuration file. You can load the file to configure the IP.

Note!

If VHDL is selected as the hardware description language, the first two files will be named with .vhd suffix.

7 Initialization File

In BSRAM and SSRAM modes, each bit of memory can be initialized to 0 or 1. The initial value is written in binary, hex, or hex with address in the initialization file.

7.1 Bin File

The Bin file is a text file consisting of 0 and 1. The row number represents the address depth, and the column number represents the data width.

```
#File_format=Bin
#Address_depth=16
#Data_width=32
00001100000100000000100100010000
10000000100100001000000010000000
01000000100000001000000010000000
00100000100001001100000011000000
```

7.2 Hex File

The Hex file is similar to the Bin file, and it consists of the hexadecimal number 0~F. The row number represents the address depth and the binary bit of each row represents the data width.

```
#File_format=Hex
#Address_depth=8
#Data_width=16
3A40
A28E
0B52
1C49
D602
```

0801
03E6
4C18

7.3 Hex File with Address

The Hex file with address records the addresses and data recorded in the file. The addresses and data are composed of 0~F. The address and data are separated by a colon. The file only records the written addresses and data. The unrecorded addresses default to 0.

```
#File_format=AddrHex  
#Address_depth=256  
#Data_width=16  
9:FFFF  
23:00E0  
2a:001F  
30:1E00
```

